



CPI™/A-LOK® Tube Fittings

Catalog 4230/4233

December 2009

aerospace
climate control
electromechanical
filtration
fluid & gas handling
hydraulics
pneumatics
process control
sealing & shielding



230 rue Jean Marie Jacquard, Notre Dame de Gravenchon 76330 Port Jérôme sur Seine
TÉL : 02.32.84.81.46 - FAX : 09.70.10.61.56 - commercial@iccare.fr - www.iccare.fr



Huntsville, Alabama, USA



Barnstaple, UK

WARNING – USER RESPONSIBILITY

FAILURE OR IMPROPER SELECTION OR IMPROPER USE OF THE PRODUCTS DESCRIBED HEREIN OR RELATED ITEMS CAN CAUSE DEATH, PERSONAL INJURY AND PROPERTY DAMAGE.

This document and other information from Parker-Hannifin Corporation, its subsidiaries and authorized distributors provide product or system options for further investigation by users having technical expertise.

The user, through its own analysis and testing, is solely responsible for making the final selection of the system and components and assuring that all performance, endurance, maintenance, safety and warning requirements of the application are met. The user must analyze all aspects of the application, follow applicable industry standards, and follow the information concerning the product in the current product catalog and in any other materials provided from Parker or its subsidiaries or authorized distributors.

To the extent that Parker or its subsidiaries or authorized distributors provide component or system options based upon data or specifications provided by the user, the user is responsible for determining that such data and specifications are suitable and sufficient for all applications and reasonably foreseeable uses of the components or systems.

Offer of Sale

The items described in this document are hereby offered for sale by Parker-Hannifin Corporation, its subsidiaries or its authorized distributors. This offer and its acceptance are governed by the provisions stated in the detailed "Offer of Sale" elsewhere in this document or available at www.parker.com/ipdus.

© Copyright 2004, 2005, 2008 Parker Hannifin Corporation. All Rights Reserved.



230 rue Jean Marie Jacquard, Notre Dame de Gravenchon 76330 Port Jérôme sur Seine
TÉL : 02.32.84.81.46 - FAX : 09.70.10.61.56 - commercial@iccare.fr - www.iccare.fr

Parker Hannifin Corporation
Instrumentation Products Division
Huntsville, AL USA
<http://www.parker.com/ipdus>

Table of Contents

| | |
|--|-------------------|
| Introduction | 2 |
| Visual Index | 4 |
| Typical Raw Material Specifications | 6 |
| Tube End Dimensional Data | 6 |
| Nomenclature (How to Order) | 7 |
| CPI™/A-LOK® Options | 8 |
| Tube to Male Pipe Fittings | 9 |
| Tube to Female Pipe Fittings | 21 |
| Tube to Tube Unions | 27 |
| Port Connectors | 36 |
| 37° Flare (AN) to CPI™/A-LOK® Fittings | 48 |
| Tube to O-Ring Seal Fittings | 49 |
| Tube to Welded Systems | 58 |
| Analytical Fittings | 62 |
| Barbed Fittings | 67 |
| Components | 68 |
| Assembly & Remake Instructions | 75 |
| Gaugeability Instructions | 75 |
| Instrument Tubing Selection Guide | 76 |
| Thread & Tube End Size Chart (USA) | 80 |
| Offer of Sale | 84 |
| Parker Motion & Control Technologies | inside back cover |

Introduction

Parker CPI™/A-LOK® Instrumentation Tube Fittings are designed as leak-free connections for process, power and instrumentation applications. These single and two ferrule fittings are manufactured to the highest quality standards and are available in a broad range of sizes, materials and configurations.

Features

The Parker CPI™/A-LOK® tube fitting has been specifically designed for use on instrumentation, process and control systems, analysers and environmental equipment employed in chemical, petroleum, power generating and pulp and paper plants. CPI™/A-LOK® fittings have also been used extensively in other applications and industries wherever high reliability and quality are required.

Materials

Parker CPI™/A-LOK® fittings are available as standard in Heat Code Traceable, 316 stainless steel. Other materials include steel, brass, aluminum, nickel-copper, Hastelloy C®, Alloy 600, Titanium, 6Mo, Incoloy 625 and 825. Straight fittings are machined from cold finished bar stock and shaped bodies are machined from close grain forgings. The raw materials used fully conform to the chemical requirements listed in Specification Table 1 found on page 6. For nuclear and other critical applications, stainless steel CPI™/A-LOK® fittings are readily available with documented heat code traceability.

Pipe Fittings/Adapters

Parker CPI™/A-LOK® tube fittings are available in combination with a variety of ISO and ANSI pipe thread configurations. For a full listing of these fittings, see Catalog 4260.

Tubing

Parker CPI™/A-LOK® tube fittings can be used with a wide variety of tubing materials and a broad range of tube wall thicknesses. CPI™/A-LOK® seals equally well on both thin wall and heavy wall tubing. **Tubing and fitting materials should be selected to be compatible with the fluid media. Due to thermal expansion characteristics and chemical stability, the tubing should be of the same material as the fitting. (The exception is brass fittings and copper tubing.)**

Torque

Parker CPI™/A-LOK® tube fittings do not twist the tubing during installation. CPI™/A-LOK® ferrule designs assure that all make and remake motion is transmitted axially to the tubing. Since no radial movement of the tubing occurs, the tubing is not stressed. The mechanical integrity of the tubing is maintained.

No Distortion

In make-up, there is no undue force in an outward direction to distort the fitting body or ferrules to cause interference between the ferrules and nut. This assures that the nut will back-off freely for disassembly and permits a greater number of easy remakes.

Sealing

Positive, reliable connections with Parker CPI™/A-LOK® fittings have been qualified by exhaustive tests and over four decades of experience in the manufacture of quality tube fittings.

Nomenclature

Parker CPI™/A-LOK® fitting part numbers are constructed from symbols that identify the size and style of the fitting and material used.

Assembly, Remake, Gaugeability

Proper assembly is the key component to a leak-free system. CPI™/A-LOK® tube fitting assembly, remake and gaugeability instructions are found on page 75 of this catalog.

Pressure Rating & Tubing Selection

For working pressures of CPI™/A-LOK® tube connections, please see pages 76–79 of this catalog, the Instrument Tubing Selection Guide (4200-TS) found in the Technical Section of your Parker Instrumentation Products Process Binder, or the Parker Instrument Tube Fitting Installation Manual (Bulletin 4200-B4).

In cases where a male or female pipe thread is the second end of a Parker CPI™/A-LOK® fitting, such threads may be the pressure limiting factor of the tubing system. Pressure ratings for Pipe Ends are shown on page 79.

Parker CPI™ /A-LOK® fittings consists of precision engineered parts designed to provide secure leak-proof joints capable of satisfying high pressure, vacuum and vibration applications.

Inch — CPI™

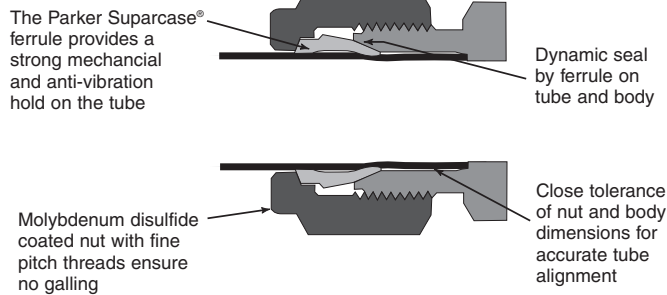

Inch — A-LOK®

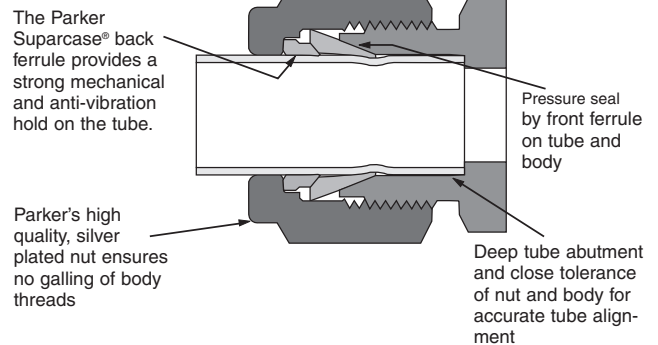

Metric — CPI™

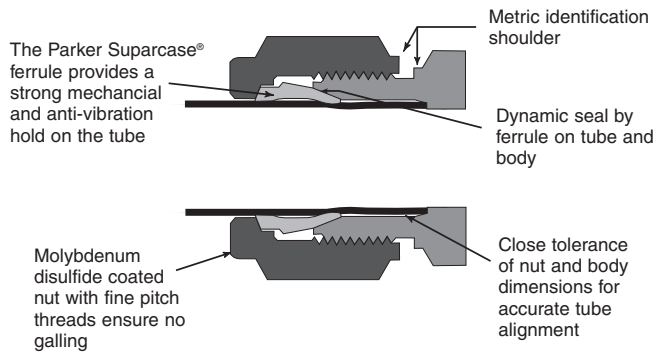

Metric — A-LOK®

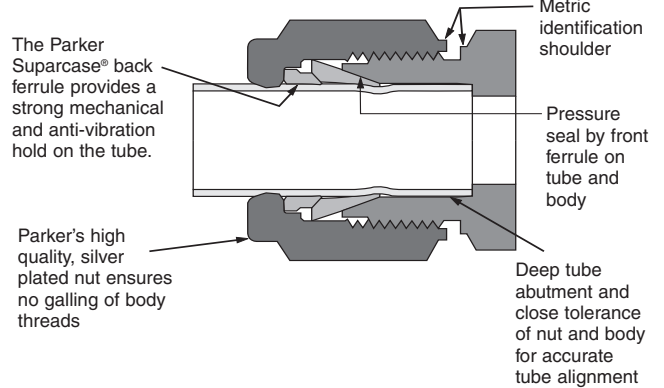

Parker Instrumentation Tube Fittings are supplied complete and ready to use. The ferrule(s) swage onto the tube as it moves down the body seat creating a pressure/vacuum-tight seal on both tube and body by the interface pressure and surface finish of mating components. The Parker Supercase® ferrule (back-ferrule only on A-LOK®) creates a strong mechanical hold on the tube.

Visual Index

Tube to Male Pipe

Male Connector

FBZ, MSC
pages 9, 10,
11, 12, 13

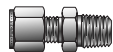

Male Bulkhead Connector

FH2BZ, MBC
page 14



Thermocouple Connector

FH4BZ, MTC
page 15



Male Elbow

CBZ, MSEL
pages 15, 16, 17



NPT Male 45° Elbow

VBZ, MVEL
page 18

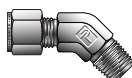

NPT Male Run Tee

RBZ, MRT
page 19

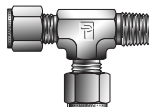

NPT Male Branch Tee

SBZ, MBT
page 20

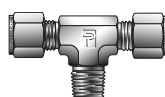

Tube to Female Pipe

Female Connector

GBZ, FSC
pages 21, 22



Female Bulkhead Connector

GH2BZ, FBC
page 23



Gauge Connector

GBZ, FSC
pages 23, 24



Female Elbow

DBZ, FEL
page 24

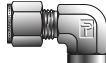

Female Run Tee

MBZ, FRT
page 25

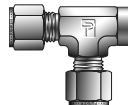

Female Branch Tee

OBZ, FBT
page 26



Tube to Tube Unions

Union

HBZ, SC
page 27



Conversion Union

HBZ, CU
page 28



Reducing Union

HBZ, RU
page 28



Bulkhead Union

WBZ, BC
page 29



Dielectric Union Adapter, Dielectric Assembly

DEBTADELTA
page 30



Union Elbow

EBZ, EE, ELZ
pages 30, 31

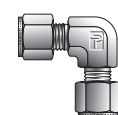

Union Tee

JBZ, ET
page 32



Drop Size Tee

JBZ, JLZ
page 33

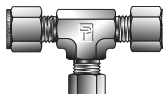

Union Cross

KBZ, ECR
page 34

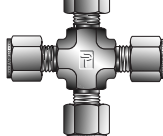

Port Connectors

Tube End Reducer

TRBZ, TUR,
TUC
pages 35, 36, 37



Tube End Bulkhead Adapter

T2H2BZ,
TUBC
page 38



Port Connector

ZPC, PC
page 38



Tube End Male Adapter

T2HF, MA
pages 39, 40,
41, 42



Tube End to SAE Straight Thread Adapter

T2HOA, TUOHA
page 43



Tube End Female Adapter

T2HG, FA
pages 43, 44, 45



Push-Lok to Tube Adapter

P2T2, P2TU
page 45



Push-Lok to Male Adapter

P2HF
page 46



Push-Lok to CPI™/A-LOK®

P2BZ6, P2LZ6
page 46



Push-Lok to Port Connector

ZPB2, ZPC2
page 46



Lapped Joint Tube Adapters

LJFBZ, LJF
page 47



DP Transmitter Calibration Adapters

ZH2LX
page 47



37° Flare (AN) to CPI™/A-LOK®

37° Flare (AN) to CPI™/A-LOK®

X6HBZ6, X6TU
page 48



37° Flare Connector to CPI™/A-LOK®

XHBZ, XASC
page 48

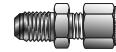

37° Flare Bulkhead Connector to CPI™/A-LOK®

XH2BZ,
XABC
page 48

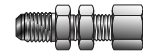

Tube to O-Ring Seal

Male Connector SAE Straight Thread

ZHBA, M1SC
page 50



Male SAE Straight Thread Elbow

C5BZ, M5SEL
page 51



Male BSPP Straight Thread Elbow

CBZ, MSEL
page 51

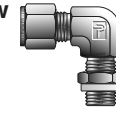

Male Run Tee SAE Straight Thread

R5BZ,
M5RT
page 52

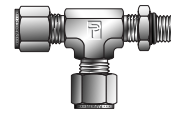

Male BSPP Run Tee Straight Thread

RBZ, MRT
page 52

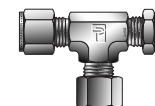

Visual Index

Male Branch Tee SAE Straight Thread

S5BZ, M5BT
page 53

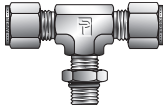

Male BSPP Branch Tee Straight Thread

SBZ, MBT
page 53

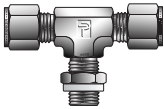

Long Male Connector SAE Straight Thread

ZH3BA, ZH3LA
page 54



45° Positionable Male Elbow

V5BZ, M5VEL
page 54



Male Connector to O-Ring Straight Thread

ZHBA5, M2SC
page 55



Male Connector to O-Ring Pipe Thread

ZHBF5, M3SC
page 55



Tube End to O-Ring Straight Thread

T2HOA5, M2TU
page 56



Tube End to O-Ring Pipe Thread

T2HOF5, M3TU
page 56



Pipe Thread to SAE Straight Thread Adapter

FHOA
page 57



Bulkhead to Conversion Adapter

AH2BZ, AH2LZ
page 57



Tube to Welded Systems

Socket Weld Elbow

ZEBW, ZELW
page 59



Buttweld Elbow

ZEBW2, ZELW2
page 59



Socket Weld Connector

ZHBW, ZHLW
page 60



Buttweld Connector

ZHBW2, ZHLW2
page 60, 61



Analytical Fittings

Column End Fitting — Low Internal Volume with Frit

Z2HCZ7, Z2HLZ7
page 63



Column End Fitting — Low Internal Volume

Z3HCZ7, Z3HLZ7
page 63



Column End Fitting — Low Internal Volume (without Frit)

ZHCZ7, ZHLZ7
page 64



Column End Fitting — with Frit

Z2HCZ, Z2HLZ
page 64



Column End Fitting (without Frit)

ZHCZ, ZHLZ
page 65



Union Connector — Low Dead Volume

Z7HBZ7, Z7HLZ7
page 65



Male Connector — Low Dead Volume

FBZ7, FLZ7
page 66



Sanitary Flange Fitting

ZHBS, ZHLS
page 66



Barbed Fittings

Barbed Connector to Male Pipe

B2HF
page 67



Barbed Connector to Tube Adapter

B2HT2, B2TU
page 67



Hose Connector Sleeve

HCS
page 67



Components

Insert

TIZ
page 68



Tube Nut

BZ, NU
page 68, 69



Inverted Tube Nut

BZI
page 69



Knurled Nut

BZP
page 69



Ferrules

TZ
page 69



Front Ferrules

FF
page 70



Back Ferrules

BF
page 70



Ferrule Holder

page 70



Plug

FNZ, BLP
page 71



Cap

PNBZ, BLEN
page 71, 72



Vent Protector

MDF
page 72



Sealing Washers Bonded Seal and Copper

page 73



Bulkhead Locknut

WLZ, WLN, BN
page 74



Accessory Locknut

L5NR
page 74



Reference Material

Assembly and Remake Instructions
page 75

Gaugeability Instructions
page 75

Instrument Tubing Selection Guide
pages 76 – 79

Pipe End Pressure Ratings
page 79

Thread and Tube End Size Charts (USA/ International)
pages 80 – 82

Offer of Sale
page 84

Table 1 – Typical Raw Material Specifications

| BASIC FITTING MATERIAL | MATERIAL DESIGNATOR | BAR STOCK | FORGING | COMMON TUBING SPECIFICATION |
|---|---|--|--|--|
| Brass | B | CA-360 QQ-B 626 Alloy 360 ASTM-B16 Alloy 360 CA-345 ASTM-B-453 Alloy 345 | CA-377 QQ-B 626 Alloy 377 ASTM-B-124 Alloy 377 BS2872 CZ122 | ASTM-B75 ASME-SB75 (TEMPER "O") |
| Stainless Steel (Type 316) ⁽¹⁾ | A-LOK® = 316 ⁽¹⁾⁽²⁾ CPI™ = SS | ASME-SA-479 Type 316-SS BS970 316-S31 DIN 4401 ASTM A276 Type 316 | ASME-SA-182 316 BS970 316-S31 DIN 4401 | ASME-SA-213 ASTM-A-213 ASTM-A-249 ASTM-A-269 ⁽³⁾ MIL T-8504 MIL T-8506 |
| Steel | S | ASTM-A-108 QQ-S-637 | ASTM-A-576 | SAE J524b SAE J525b ASTM-A-179 |
| Aluminum | A | 2017-T4 or 2024-T4 ASTM-B211 QQ-A-225/5 or 6 | 2014T (as fabricated) ASTM-B-211 QQ-A-225/4 | 303, 6061T6 ASTM-B-210 |
| Monel® 400 – Forgings Monel® 405 – Bar Stock | M | ASTM-B-164 QQ-N-281 BS3076 NA13 | ASTM-B-164 QQ-N-281 BS3076 NA13 | ASTM-B-165 |
| Hastelloy® C-276 | HC | ASTM-B-574 ASTMB575 | ASTM-B-574 | ASTM-B-622 ASTM-B-626 |
| Inconel® Alloy 600 | IN | ASTM B-166 ASME-SB-166 | ASTM-B-564 | ASTM-B-163 |
| Carpenter® 20 | SS20 | ASTM-B-473 | ASTM-B-462 ASTM-B-472 | ASTM-B-468 |
| Titanium | T | ASTM-B-348 | ASTM-B-381 | ASTM-B-338 |
| Inconel® Alloy 625 | 625 | BS3076 NA16 ASTMB425 | BS3076 NA16 ASTMB425 | ASTM-B-625 ASTM-B-444 ASTM-B-423 ASTM-B-829 |
| Incoloy® Alloy 825 | 825 | | | |
| 6MO | 6MO | UNS S31254 UNS N08367 ASTM A479 | UNS S31254 UNS N08367 ASTM A 479 | ASTM-A-269 |

(1) If more specific information, including heat code traceability, is required, your Parker Hannifin CPI™/A-LOK® distributor will provide details.

(2) If an "L" appears in the A-LOK® fitting description, then the material designator will be "SS" (e.g., JLZ drop size tee).

(3) Stainless steel CPI™/A-LOK® tube fittings work reliably on both seamless and welded-redrawn, fully annealed type 304, 316 and 316L tubing.

NOTE: Hastelloy® is a registered trademark of Haynes International. Inconel®, Incoloy® and Monel® are registered trademarks of Special Metals Corporation. Carpenter® is a registered trademark of CRS Holdings Inc.

Tube End Dimensional Data

| SIZE NO. | INCHES | | | | | |
|----------|-----------|-----------------|------|-------|--------|--------------------|
| | TUBE O.D. | STRAIGHT THREAD | †C | H HEX | E DIA. | †D TUBE INS. DEPTH |
| 1 | 1/16 | 10-32 | .43 | 5/16 | .052 | .34 |
| 2 | 1/8 | 5/16-20 | .60 | 7/16 | .093 | .50 |
| 3 | 3/16 | 3/8-20 | .64 | 1/2 | .125 | .54 |
| 4 | 1/4 | 7/16-20 | .70 | 9/16 | .187 | .60 |
| 5 | 5/16 | 1/2-20 | .73 | 5/8 | .250 | .64 |
| 6 | 3/8 | 9/16-20 | .76 | 11/16 | .281 | .67 |
| 8 | 1/2 | 3/4-20 | .87 | 7/8 | .406 | .90 |
| 10 | 5/8 | 7/8-20 | .87 | 1 | .500 | .96 |
| 12 | 3/4 | 1-20 | .87 | 1-1/8 | .625 | .96 |
| 14 | 7/8 | 1-1/8-20 | .87 | 1-1/4 | .750 | 1.03 |
| 16 | 1 | 1-5/16-20 | 1.05 | 1-1/2 | .875 | 1.24 |
| 20 | 1-1/4 | 1-5/8-20 | 1.52 | 1-7/8 | 1.09 | 1.61 |
| 24 | 1-1/2 | 1-15/16-20 | 1.77 | 2-1/4 | 1.34 | 1.96 |
| 32 | 2 | 2-5/8-20 | 2.47 | 2-3/4 | 1.81 | 2.65 |

NOTE: Dimensions C and D are shown in the finger-tight position.

† Average Value

Dimensions for reference only, subject to change.

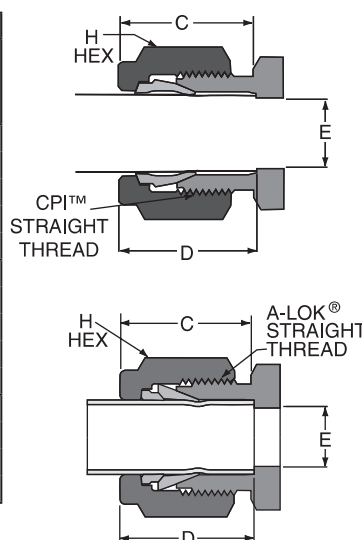

| SIZE NO. | MILLIMETERS | | | | | |
|----------|-------------|-----------------|------|-------|--------|--------------------|
| | TUBE O.D. | STRAIGHT THREAD | †C | H HEX | E DIA. | †D TUBE INS. DEPTH |
| 2 | 2mm | 5/16-20 | 15,3 | 12,0 | 1,7 | 12,9 |
| 3 | 3mm | 5/16-20 | 15,3 | 12,0 | 2,4 | 12,9 |
| 4 | 4mm | 3/8-20 | 16,1 | 12,0 | 2,4 | 13,7 |
| 6 | 6mm | 7/16-20 | 17,7 | 14,0 | 4,8 | 15,3 |
| 8 | 8mm | 1/2-20 | 18,6 | 15,0 | 6,4 | 16,2 |
| 10 | 10mm | 5/8-20 | 19,5 | 18,0 | 7,9 | 17,2 |
| 12 | 12mm | 3/4-20 | 22,0 | 22,0 | 9,5 | 22,8 |
| 14 | 14mm | 7/8-20 | 22,0 | 24,0 | 11,1 | 24,4 |
| 15 | 15mm | 7/8-20 | 22,0 | 24,0 | 11,9 | 24,4 |
| 16 | 16mm | 7/8-20 | 22,0 | 24,0 | 12,7 | 24,4 |
| 18 | 18mm | 1-20 | 22,0 | 27,0 | 15,1 | 24,4 |
| 20 | 20mm | 1-1/8-20 | 22,0 | 30,0 | 15,9 | 26,0 |
| 22 | 22mm | 1-1/8-20 | 22,0 | 30,0 | 18,3 | 26,0 |
| 25 | 25mm | 1-5/16-20 | 26,5 | 35,0 | 21,8 | 31,3 |

NOTE: Dimensions C and D are shown in the finger-tight position.

† Average Value

Dimensions for reference only, subject to change.

Nomenclature/How to Order

Parker CPI™/A-LOK® tube fitting part numbers are constructed using alphanumeric characters to identify the size, style and material of the fitting.

CPI™ Inch Parts



Example: 8 – 4 – FBZ – SS – (blank)
 1/2" Tube O.D. – 1/4" Pipe Thread (blank – see Note 1 below) Male Connector – Stainless Steel – (blank)

Part Number as it is ordered (without options): 8-4 FBZ-SS. This part appears on page 9 and is a CPI™ NPT male connector.

A-LOK® Inch Parts



Example: 8 – MSC – 4 – N – 316 – (blank)
 1/2" Tube O.D. Male Connector 1/4" Pipe Thread NPT – Stainless Steel – (blank)

Part Number as it is ordered (without options): 8MSC4N-316. This part appears on page 9 and is an A-LOK® NPT male connector.

CPI™ Metric Parts



Example: GBZ – 12 – 1/4 – K – SS – (blank)
 Female Connector 12mm – 1/4" BSP – Stainless Steel – (blank)

Part Number as it is ordered (without options): GBZ 12-1/4K-SS. This part appears on page 21 and is a CPI™ NPT female connector.

A-LOK® Metric Parts

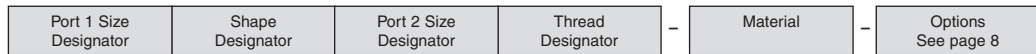

Example: M12 – FSC – 1/4 – N – 316 – (blank)
 12mm Female Connector 1/4" NPT – Stainless Steel – (blank)

Part Number as it is ordered (without options): M12FSC1/4N-316. This part appears on page 21 and is an A-LOK® NPT female connector.

Body Designator: A letter or combination of letters and numbers are used to designate the type of fitting. See the visual index on pages 4–5 for body designator.

Fractional Size: Tube and pipe thread sizes are designed by the number of sixteenths of an inch (1/2" tube = 8/16" = 8) (1/4" pipe thread = 4/16" = 4).

Metric Size: Metric tube is designated in millimeters and prefixed "M" (i.e., 12mm tube – M12.) The pipe thread size is written as a fraction (i.e., 1/4 NPT = 1/4).

All Straights & Elbows: Call out largest CPI™/A-LOK® tube end size first followed by the smaller CPI™/A-LOK® tube end or pipe thread size.

Fractional Tees & Crosses: For drop size tees – first size the run (1 to 2) and then branch (3). Example – the size designator for a male run tee for 3/8" O.D. tube and 1/4" male pipe thread would be 6-4-6. For crosses – first size the run (1 to 2) and then the branch (3 to 4). For tees with all ends the same, use the tube and size before and after the style designator; i.e. 4-4-4 JBZ (CPI™), 4ET4 (A-LOK®).

Metric Tees & Crosses: For drop size tees – first size the run (1 to 2) and then branch (3). Example – the size designator for a male run tee for 6mm tube and 1/4" male pipe thread would be 6-4-6. For crosses – first size the run (1 to 2) and then the branch (3 to 4). For tees with all ends the same, use the tube end size after the style designator; i.e. JBZ 4-4-4 JBZ (CPI™), ETM4 (A-LOK®).

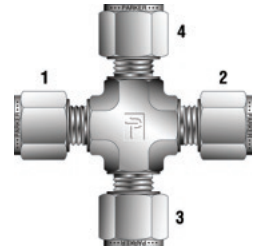

Material: See Table 1 on the previous page for the material symbol.

Thread Types:

| | |
|---|---|
| N = NPT ⁽¹⁾ /National Pipe Taper | ANSI B1.20.1 |
| K = BSP/ISO Taper | BS21, ISO7/1 |
| R = BSP/ISO Parallel | BS2779, ISO 228/1+2, DIN 3852 FORM A ⁽²⁾ |
| BR = BSP/ISO Parallel | BS2779, ISO 228/1+2, DIN 3852 FORM B ⁽³⁾ |
| M = Metric Thread | ISO 6149-2 |
| R-ED = BSPP/ISO Parallel | BS2779, ISO 228/1+2, DIN 3852 with elastic sealing washer ⁽⁴⁾ |
| GC = BSPP Gauge Connector | B2779, ISO 228/1+2, DIN 3852 |

- (1) N thread designator is only used for A-LOK® nomenclature.
- (2) Form A requires the use of a bonded washer. See page 73 of this catalog.
- (3) Form B (cutting face) may be used with or without a sealing washer.
- (4) ED fittings are supplied with Nitrile sealing washers as standard. Fluorocarbon seals are available upon request.

Special Fittings: Consult the factory. If there is any question as to the fitting desired, particularly for special fitting configurations, it is suggested that a customer print be submitted.

Special Options: See the following page for available options.

Color Coding

For easy reference, table column headings are color indicated as follows:

fractional

metric



CPI™/A-LOK® Options

Parker CPI™/A-LOK® fittings may be ordered with the following options.

How to order

After the complete CPI™/A-LOK® number simply add a "dash" then the suffix for the option.

The following example is an A-LOK® male connector for 1/2" OD tube and 1/4" male pipe that has been cleaned for oxygen service. For additional options, please consult the factory.

8MSC4N-316-C

| Suffix | Option | Additional Information |
|--------|--|---|
| ZYF | Assembled with nylon ferrule(s) | |
| SPF | Silver plated ferrule(s) | |
| TF | PTFE ferrule(s) | |
| BP* | Bulk packed | * Indicates the quantity i.e BP50 for a fifty count package. |
| LWH | Lock wire hole | |
| BZP | Knurled nut | Replaces standard nut on CPI™/A-LOK® fittings for use on soft plastic tubing. |
| C | Silver plated nut | Replaces moly coated nut (BZ). |
| MI | Moly inside nut | |
| CNQ | Certified Nuclear Quality | |
| C1 | Grade A Cleaning | Special cleaning, assembly, inspection and packaging for high purity applications. |
| C3 | Cleaned for oxygen service | Meets the requirements of ASTM G93-88; Standard Practice for Cleaning Methods for Materials and Equipment used in Oxygen-Enriched Environments. |
| CNG | Compressed natural gas service | Assembled with a specific o-ring compound. |
| NIC | Nickel plated | |
| CRM | Chrome plated | |
| VO | Viton O-ring | |
| NC | NACE | MRO175-2003 |
| NACE | NACE | MRO175-2002 |
| DFARS | Defense Acquisition Regulations System | All components and raw material must be of US origin or from an approved country. |

NPT Male Connector For fractional tube

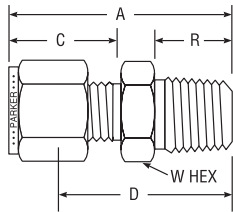
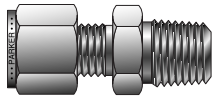

| CPI™ PART NO. | A-LOK® PART NO. | INTER- CHANGES WITH | INCHES | | | | | | |
|------------------|--------------------|---------------------------|--------------|--------------------|------|------|------|------|----------|
| | | | TUBE O.D. | NPT PIPE THREAD | A | C | D | R | W HEX |
| 1-1 FBZ | 1MSC1N | 100-1-1 | 1/16 | 1/16 | .93 | .43 | .78 | .38 | 5/16 |
| 1-2 FBZ | 1MSC2N | 100-1-2 | 1/16 | 1/8 | 1.03 | .43 | .88 | .38 | 7/16 |
| 1-4 FBZ | 1MSC4N | 100-1-4 | 1/16 | 1/4 | 1.23 | .43 | 1.08 | .56 | 9/16 |
| 2-1 FBZ | 2MSC1N | 200-1-1 | 1/8 | 1/16 | 1.17 | .60 | .91 | .38 | 3/8 |
| 2-2 FBZ | 2MSC2N | 200-1-2 | 1/8 | 1/8 | 1.20 | .60 | .94 | .38 | 7/16 |
| 2-4 FBZ | 2MSC4N | 200-1-4 | 1/8 | 1/4 | 1.40 | .60 | 1.14 | .56 | 9/16 |
| 2-6 FBZ | 2MSC6N | 200-1-6 | 1/8 | 3/8 | 1.42 | .60 | 1.16 | .56 | 11/16 |
| 2-8 FBZ | 2MSC8N | 200-1-8 | 1/8 | 1/2 | 1.67 | .60 | 1.41 | .75 | 7/8 |
| 3-1 FBZ | 3MSC1N | 300-1-1 | 3/16 | 1/16 | 1.23 | .64 | .97 | .38 | 7/16 |
| 3-2 FBZ | 3MSC2N | 300-1-2 | 3/16 | 1/8 | 1.23 | .64 | .97 | .38 | 7/16 |
| 3-4 FBZ | 3MSC4N | 300-1-4 | 3/16 | 1/4 | 1.43 | .64 | 1.17 | .56 | 9/16 |
| 4-1 FBZ | 4MSC1N | 400-1-1 | 1/4 | 1/16 | 1.29 | .70 | 1.00 | .38 | 1/2 |
| 4-2 FBZ | 4MSC2N | 400-1-2 | 1/4 | 1/8 | 1.29 | .70 | 1.00 | .38 | 1/2 |
| 4-4 FBZ | 4MSC4N | 400-1-4 | 1/4 | 1/4 | 1.49 | .70 | 1.20 | .56 | 9/16 |
| 4-6 FBZ | 4MSC6N | 400-1-6 | 1/4 | 3/8 | 1.51 | .70 | 1.22 | .56 | 11/16 |
| 4-8 FBZ | 4MSC8N | 400-1-8 | 1/4 | 1/2 | 1.76 | .70 | 1.47 | .75 | 7/8 |
| 4-12 FBZ | 4MSC12N | 400-1-12 | 1/4 | 3/4 | 1.82 | .70 | 1.53 | .75 | 1-1/16 |
| 5-2 FBZ | 5MSC2N | 500-1-2 | 5/16 | 1/8 | 1.34 | .73 | 1.05 | .38 | 9/16 |
| 5-4 FBZ | 5MSC4N | 500-1-4 | 5/16 | 1/4 | 1.52 | .73 | 1.23 | .56 | 9/16 |
| 5-6 FBZ | 5MSC6N | 500-1-6 | 5/16 | 3/8 | 1.55 | .73 | 1.25 | .56 | 11/16 |
| 5-8 FBZ | 5MSC8N | 500-1-8 | 5/16 | 1/2 | 1.79 | .73 | 1.5 | .75 | 7/8 |
| 6-2 FBZ | 6MSC2N | 600-1-2 | 3/8 | 1/8 | 1.38 | .76 | 1.09 | .38 | 5/8 |
| 6-4 FBZ | 6MSC4N | 600-1-4 | 3/8 | 1/4 | 1.57 | .76 | 1.28 | .56 | 5/8 |
| 6-6 FBZ | 6MSC6N | 600-1-6 | 3/8 | 3/8 | 1.57 | .76 | 1.28 | .56 | 11/16 |
| 6-8 FBZ | 6MSC8N | 600-1-8 | 3/8 | 1/2 | 1.82 | .76 | 1.53 | .75 | 7/8 |
| 6-12 FBZ | 6MSC12N | 600-1-12 | 3/8 | 3/4 | 1.88 | .76 | 1.59 | .75 | 1-1/16 |
| 8-2 FBZ | 8MSC2N | 810-1-2 | 1/2 | 1/8 | 1.53 | .87 | 1.13 | .38 | 13/16 |
| 8-4 FBZ | 8MSC4N | 810-1-4 | 1/2 | 1/4 | 1.71 | .87 | 1.31 | .56 | 13/16 |
| 8-6 FBZ | 8MSC6N | 810-1-6 | 1/2 | 3/8 | 1.71 | .87 | 1.31 | .56 | 13/16 |
| 8-8 FBZ | 8MSC8N | 810-1-8 | 1/2 | 1/2 | 1.93 | .87 | 1.53 | .75 | 7/8 |
| 8-12 FBZ | 8MSC12N | 810-1-12 | 1/2 | 3/4 | 1.99 | .87 | 1.59 | .75 | 1-1/16 |
| 8-16 FBZ | 8MSC16N | 810-1-16 | 1/2 | 1 | 2.28 | .87 | 1.88 | .94 | 1-3/8 |
| 10-6 FBZ | 10MSC6N | 1010-1-6 | 5/8 | 3/8 | 1.74 | .87 | 1.34 | .56 | 15/16 |
| 10-8 FBZ | 10MSC8N | 1010-1-8 | 5/8 | 1/2 | 1.93 | .87 | 1.53 | .75 | 15/16 |
| 10-12 FBZ | 10MSC12N | 1010-1-12 | 5/8 | 3/4 | 1.99 | .87 | 1.59 | .75 | 1-1/16 |
| 12-8 FBZ | 12MSC8N | 1210-1-8 | 3/4 | 1/2 | 1.99 | .87 | 1.59 | .75 | 1-1/16 |
| 12-12 FBZ | 12MSC12N | 1210-1-12 | 3/4 | 3/4 | 1.99 | .87 | 1.59 | .75 | 1-1/16 |
| 12-16 FBZ | 12MSC16N | 1210-1-16 | 3/4 | 1 | 2.28 | .87 | 1.88 | .94 | 1-3/8 |
| 14-12 FBZ | 14MSC12N | 1410-1-12 | 7/8 | 3/4 | 1.99 | .87 | 1.59 | .75 | 1-3/16 |
| 14-16 FBZ | 14MSC16N | 1410-1-16 | 7/8 | 1 | 2.28 | .87 | 1.88 | .94 | 1-3/8 |
| 16-8 FBZ | 16MSC8N | 1610-1-8 | 1 | 1/2 | 2.27 | 1.05 | 1.78 | .75 | 1-3/8 |
| 16-12 FBZ | 16MSC12N | 1610-1-12 | 1 | 3/4 | 2.27 | 1.05 | 1.78 | .75 | 1-3/8 |
| 16-16 FBZ | 16MSC16N | 1610-1-16 | 1 | 1 | 2.46 | 1.05 | 1.97 | .94 | 1-3/8 |
| 20-20 FBZ | 20MSC20N | 2010-1-20 | 1-1/4 | 1-1/4 | 3.03 | 1.52 | 2.17 | .97 | 1-3/4 |
| 24-24 FBZ | 24MSC24N | 2410-1-24 | 1-1/2 | 1-1/2 | 3.50 | 1.77 | 2.44 | 1.00 | 2-1/8 |
| 32-32 FBZ | 32MSC32N | 3210-1-32 | 2 | 2 | 4.47 | 2.47 | 3.00 | 1.04 | 2-3/4 |

NOTE: A and C dimensions are typical finger-tight.

Dimensions for reference only, subject to change.

Sizes 20, 24, 32 require additional lubrication prior to assembly.

Color Coding

For easy reference, table column headings are color indicated as follows:

fractional



metric



NPT Male Connector For metric tube

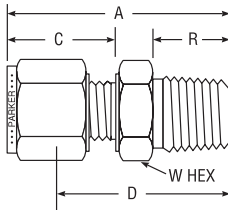
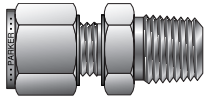

| CPI™ PART NO. | A-LOK® PART NO. | INTER- CHANGES WITH | MILLIMETERS | | | | | | |
|------------------|--------------------|---------------------------|--------------|--------------------|------|------|-------|------|----------|
| | | | TUBE O.D. | NPT PIPE THREAD | A | C | D | R | W HEX |
| FBZ 2-1/8 | M2MSC1/8N | 2MO-1-2 | 2 | 1/8 | 29,7 | 15,3 | 23,1 | 9,5 | 12,0 |
| FBZ 3-1/8 | M3MSC1/8N | 3MO-1-2 | 3 | 1/8 | 29,7 | 15,3 | 23,1 | 9,5 | 12,0 |
| FBZ 3-1/4 | M3MSC1/4N | 3MO-1-4 | 3 | 1/4 | 35,3 | 15,3 | 28,7 | 14,3 | 14,0 |
| FBZ 4-1/8 | M4MSC1/8N | 4MO-1-2 | 4 | 1/8 | 31,2 | 16,1 | 24,6 | 9,5 | 12,0 |
| FBZ 4-1/4 | M4MSC1/4N | 4MO-1-4 | 4 | 1/4 | 36,3 | 16,1 | 29,7 | 14,3 | 14,0 |
| FBZ 6-1/8 | M6MSC1/8N | 6MO-1-2 | 6 | 1/8 | 32,9 | 17,7 | 25,4 | 9,5 | 14,0 |
| FBZ 6-1/4 | M6MSC1/4N | 6MO-1-4 | 6 | 1/4 | 38,1 | 17,7 | 30,6 | 14,3 | 14,0 |
| FBZ 6-3/8 | M6MSC3/8N | 6MO-1-6 | 6 | 3/8 | 38,5 | 17,7 | 31,0 | 14,3 | 18,0 |
| FBZ 6-1/2 | M6MSC1/2N | 6MO-1-8 | 6 | 1/2 | 44,8 | 17,7 | 37,3 | 19,1 | 22,0 |
| FBZ 8-1/8 | M8MSC1/8N | 8MO-1-2 | 8 | 1/8 | 34,2 | 18,6 | 26,7 | 9,5 | 15,0 |
| FBZ 8-1/4 | M8MSC1/4N | 8MO-1-4 | 8 | 1/4 | 38,8 | 18,6 | 31,3 | 14,3 | 15,0 |
| FBZ 8-3/8 | M8MSC3/8N | 8MO-1-6 | 8 | 3/8 | 39,3 | 18,6 | 31,8 | 14,3 | 18,0 |
| FBZ 8-1/2 | M8MSC1/2N | 8MO-1-8 | 8 | 1/2 | 45,6 | 18,6 | 38,1 | 19,1 | 22,0 |
| FBZ 10-1/8 | M10MSC1/8N | 10MO-1-2 | 10 | 1/8 | 36,1 | 19,5 | 28,6 | 9,5 | 18,0 |
| FBZ 10-1/4 | M10MSC1/4N | 10MO-1-4 | 10 | 1/4 | 40,9 | 19,5 | 33,3 | 14,3 | 18,0 |
| FBZ 10-3/8 | M10MSC3/8N | 10MO-1-6 | 10 | 3/8 | 40,9 | 19,5 | 33,3 | 14,3 | 18,0 |
| FBZ 10-1/2 | M10MSC1/2N | 10MO-1-8 | 10 | 1/2 | 47,5 | 19,5 | 38,9 | 19,1 | 22,0 |
| FBZ 10-3/4 | M10MSC3/4N | 10MO-1-12 | 10 | 3/4 | 46,4 | 19,5 | 38,9 | 19,1 | 27,0 |
| FBZ 10-1 | M10MSC1N | 10MO-1-16 | 10 | 1 | 55,0 | 19,5 | 47,5 | 23,8 | 35,0 |
| FBZ 12-1/4 | M12MSC1/4N | 12MO-1-4 | 12 | 1/4 | 43,4 | 22,0 | 33,3 | 14,3 | 22,0 |
| FBZ 12-3/8 | M12MSC3/8N | 12MO-1-6 | 12 | 3/8 | 43,4 | 22,0 | 33,3 | 14,3 | 22,0 |
| FBZ 12-1/2 | M12MSC1/2N | 12MO-1-8 | 12 | 1/2 | 49,0 | 22,0 | 38,9 | 19,1 | 22,0 |
| FBZ 12-3/4 | M12MSC3/4N | 12MO-1-12 | 12 | 3/4 | 50,5 | 22,0 | 40,4 | 19,1 | 27,0 |
| FBZ 14-1/4 | M14MSC1/4N | 14MO-1-4 | 14 | 1/4 | 44,2 | 22,0 | 34,1 | 14,3 | 24,0 |
| FBZ 14-3/8 | M14MSC3/8N | 14MO-1-6 | 14 | 3/8 | 44,2 | 22,0 | 34,1 | 14,3 | 24,0 |
| FBZ 14-1/2 | M14MSC1/2N | 14MO-1-8 | 14 | 1/2 | 49,0 | 22,0 | 38,9 | 19,1 | 24,0 |
| FBZ 15-1/2 | M15MSC1/2N | 15MO-1-8 | 15 | 1/2 | 49,0 | 22,0 | 38,9 | 19,1 | 24,0 |
| FBZ 16-3/8 | M16MSC3/8N | 16MO-1-6 | 16 | 3/8 | 44,1 | 22,0 | 34,01 | 14,3 | 24,0 |
| FBZ 16-1/2 | M16MSC1/2N | 16MO-1-8 | 16 | 1/2 | 49,0 | 22,0 | 38,9 | 19,1 | 24,0 |
| FBZ 16-3/4 | M16MSC3/4N | 16MO-1-12 | 16 | 3/4 | 50,5 | 22,0 | 40,5 | 19,1 | 27,0 |
| FBZ 18-1/2 | M18MSC1/2N | 18MO-1-8 | 18 | 1/2 | 50,6 | 22,0 | 40,5 | 19,1 | 27,0 |
| FBZ 18-3/4 | M18MSC3/4N | 18MO-1-12 | 18 | 3/4 | 50,6 | 22,0 | 40,5 | 19,1 | 27,0 |
| FBZ 20-1/2 | M20MSC1/2N | 20MO-1-8 | 20 | 1/2 | 50,6 | 22,0 | 42,2 | 19,1 | 30,0 |
| FBZ 20-3/4 | M20MSC3/4N | 20MO-1-12 | 20 | 3/4 | 52,3 | 22,0 | 42,2 | 19,1 | 30,0 |
| FBZ 20-1 | M20MSC1N | 20MO-1-16 | 20 | 1 | 57,7 | 22,0 | 47,6 | 23,8 | 35,0 |
| FBZ 22-3/4 | M22MSC3/4N | 22MO-1-12 | 22 | 3/4 | 52,3 | 22,0 | 42,2 | 19,1 | 35,0 |
| FBZ 24-1/2 | M25MSC1/2N | 25MO-1-8 | 25 | 1/2 | 57,5 | 26,5 | 45,3 | 19,1 | 35,0 |
| FBZ 25-3/4 | M25MSC3/4N | 25MO-1-12 | 25 | 3/4 | 57,5 | 26,5 | 45,2 | 19,1 | 35,0 |
| FBZ 25-1 | M25MSC1N | 25MO-1-16 | 25 | 1 | 62,3 | 26,5 | 50,0 | 23,8 | 35,0 |

NOTE: A and C dimensions are typical finger-tight.

Dimensions for reference only, subject to change.

BSP Taper Male Connector

For fractional tube

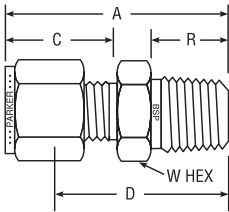
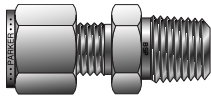

| CPI™ PART NO. | A-LOK® PART NO. | INTER- CHANGES WITH | INCHES | | | | | | | |
|------------------|--------------------|---------------------------|---------------|----------------|------|-----|------|-----|----------|------|
| | | | TUBE O. D. | BSPT THREAD | A | C | D | R | W HEX | BORE |
| 2-2K FBZ | 2MSC2K | 200-1-2RT | 1/8 | 1/8 | 1.20 | .60 | 0.94 | .38 | 7/16 | .19 |
| 2-4K FBZ | 2MSC4K | 200-1-4RT | 1/8 | 1/4 | 1.40 | .60 | 1.14 | .56 | 9/16 | .19 |
| 4-2K FBZ | 4MSC2K | 400-1-2RT | 1/4 | 1/8 | 1.30 | .70 | 1.00 | .38 | 1/2 | .19 |
| 4-4K FBZ | 4MSC4K | 400-1-4RT | 1/4 | 1/4 | 1.50 | .70 | 1.20 | .56 | 9/16 | .19 |
| 4-6K FBZ | 4MSC6K | 400-1-6RT | 1/4 | 3/8 | 1.52 | .70 | 1.22 | .56 | 11/16 | .19 |
| 4-8K FBZ | 4MSC8K | 400-1-8RT | 1/4 | 1/2 | 1.77 | .70 | 1.47 | .75 | 7/8 | .19 |
| 5-2K FBZ | 5MSC2K | 500-1-2RT | 5/16 | 1/8 | 1.34 | .73 | 1.05 | .38 | 9/16 | .19 |
| 5-4K FBZ | 5MSC4K | 500-1-4RT | 5/16 | 1/4 | 1.52 | .73 | 1.23 | .56 | 9/16 | .19 |
| 6-2K FBZ | 6MSC2K | 600-1-2RT | 3/8 | 1/8 | 1.39 | .76 | 1.09 | .38 | 5/8 | .19 |
| 6-4K FBZ | 6MSC4K | 600-1-4RT | 3/8 | 1/4 | 1.57 | .76 | 1.28 | .56 | 11/16 | .28 |
| 6-6K FBZ | 6MSC6K | 600-1-6RT | 3/8 | 3/8 | 1.57 | .76 | 1.28 | .56 | 11/16 | .28 |
| 6-8K FBZ | 6MSC8K | 600-1-8RT | 3/8 | 1/2 | 1.82 | .76 | 1.53 | .75 | 7/8 | .28 |
| 8-4K FBZ | 8MSC4K | 810-1-4RT | 1/2 | 1/4 | 1.69 | .86 | 1.31 | .56 | 13/16 | .28 |
| 8-6K FBZ | 8MSC6K | 810-1-6RT | 1/2 | 3/8 | 1.69 | .86 | 1.31 | .56 | 13/16 | .38 |
| 8-8K FBZ | 8MSC8K | 810-1-8RT | 1/2 | 1/2 | 1.91 | .66 | 1.53 | .75 | 7/8 | .41 |

NOTE: A and C dimensions are typical finger-tight.

Dimensions for reference only, subject to change.

BSP Taper Male Connector

For metric tube

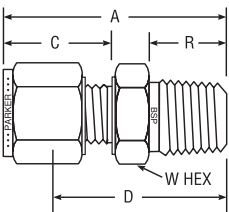
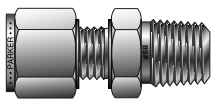

| CPI™ PART NO. | A-LOK® PART NO. | INTER- CHANGES WITH | MILLIMETERS | | | | | | |
|------------------|--------------------|---------------------------|---------------|----------------|------|------|------|------|----------|
| | | | TUBE O. D. | BSPT THREAD | A | C | D | R | W HEX |
| FBZ 2-1/8K | M2MSC1/8K | 2MO-1-2RT | 2 | 1/8 | 29,7 | 15,3 | 23,1 | 9,5 | 12,0 |
| FBZ 3-1/8K | M3MSC1/8K | 3MO-1-2RT | 3 | 1/8 | 29,7 | 15,3 | 23,1 | 9,7 | 12,0 |
| FBZ 3-1/4K | M3MSC1/4K | 3MO-1-4RT | 3 | 1/4 | 35,3 | 15,3 | 28,7 | 14,2 | 14,0 |
| FBZ 4-1/8K | M4MSC1/8K | 4MO-1-2RT | 4 | 1/8 | 31,2 | 16,1 | 24,6 | 9,7 | 12,0 |
| FBZ 4-1/4K | M4MSC1/4K | 4MO-1-4RT | 4 | 1/4 | 36,3 | 16,1 | 29,7 | 14,2 | 14,0 |
| FBZ 6-1/8K | M6MSC1/8K | 6MO-1-2RT | 6 | 1/8 | 32,9 | 17,7 | 25,4 | 9,7 | 14,0 |
| FBZ 6-1/4K | M6MSC1/4K | 6MO-1-4RT | 6 | 1/4 | 40,0 | 17,7 | 30,5 | 14,2 | 14,0 |
| FBZ 6-3/8K | M6MSC3/8K | 6MO-1-6RT | 6 | 3/8 | 38,5 | 17,7 | 31,0 | 14,2 | 18,0 |
| FBZ 6-1/2K | M6MSC1/2K | 6MO-1-8RT | 6 | 1/2 | 45,6 | 17,7 | 38,1 | 19,1 | 22,0 |
| FBZ 8-1/8K | M8MSC1/8K | 8MO-1-2RT | 8 | 1/8 | 33,9 | 18,6 | 26,4 | 9,5 | 15,0 |
| FBZ 8-1/4K | M8MSC1/4K | 8MO-1-4RT | 8 | 1/4 | 38,7 | 18,6 | 31,2 | 14,2 | 15,0 |
| FBZ 8-3/8K | M8MSC3/8K | 8MO-1-6RT | 8 | 3/8 | 39,3 | 18,6 | 31,8 | 14,2 | 18,0 |
| FBZ 8-1/2K | M8MSC1/2K | 8MO-1-8RT | 8 | 1/2 | 45,6 | 18,6 | 38,1 | 19,1 | 22,0 |
| FBZ 10-1/8K | M10MSC1/8K | 10MO-1-2RT | 10 | 1/8 | 36,2 | 19,5 | 28,6 | 9,5 | 18,0 |
| FBZ 10-1/4K | M10MSC1/4K | 10MO-1-4RT | 10 | 1/4 | 40,9 | 19,5 | 33,3 | 14,2 | 18,0 |
| FBZ 10-3/8K | M10MSC3/8K | 10MO-1-6RT | 10 | 3/8 | 40,9 | 19,5 | 33,3 | 14,2 | 18,0 |
| FBZ 10-1/2K | M10MSC1/2K | 10MO-1-8RT | 10 | 1/2 | 46,5 | 19,5 | 38,9 | 19,1 | 22,0 |
| FBZ 12-1/4K | M12MSC1/4K | 12MO-1-4RT | 12 | 1/4 | 43,4 | 22,0 | 33,3 | 14,2 | 22,0 |
| FBZ 12-3/8K | M12MSC3/8K | 12MO-1-6RT | 12 | 3/8 | 43,4 | 22,0 | 33,3 | 14,2 | 22,0 |
| FBZ 12-1/2K | M12MSC1/2K | 12MO-1-8RT | 12 | 1/2 | 49,0 | 22,0 | 38,9 | 19,1 | 22,0 |
| FBZ 12-3/4K | M12MSC3/4K | 12MO-1-12RT | 12 | 3/4 | 49,5 | 22,0 | 40,4 | 19,1 | 27,0 |
| FBZ 15-1/2K | M15MSC1/2K | 15MO-1-8RT | 15 | 1/2 | 49,0 | 22,0 | 38,9 | 19,1 | 24,0 |
| FBZ 16-3/8K | M16MSC3/8K | 16MO-1-6RT | 16 | 3/8 | 44,2 | 22,0 | 34,1 | 14,2 | 24,0 |
| FBZ 16-1/2K | M16MSC1/2K | 16MO-1-8RT | 16 | 1/2 | 49,0 | 22,0 | 38,9 | 19,1 | 24,0 |
| FBZ 16-3/4K | M16MSC3/4K | 16MO-1-12RT | 16 | 3/4 | 49,5 | 22,0 | 40,5 | 19,1 | 27,0 |
| FBZ 18-1/2K | M18MSC1/2K | 18MO-1-8RT | 18 | 1/2 | 50,6 | 22,0 | 40,4 | 19,1 | 27,0 |
| FBZ 18-3/4K | M18MSC3/4K | 18MO-1-12RT | 18 | 3/4 | 50,6 | 22,0 | 40,4 | 19,1 | 27,0 |
| FBZ 20-1/2K | M20MSC1/2K | 20MO-1-8RT | 20 | 1/2 | 52,3 | 22,0 | 42,2 | 19,1 | 30,0 |
| FBZ 20-3/4K | M20MSC3/4K | 20MO-1-12RT | 20 | 3/4 | 52,3 | 22,0 | 42,2 | 19,1 | 30,0 |
| FBZ 22-3/4K | M22MSC3/4K | 22MO-1-12RT | 22 | 3/4 | 52,3 | 22,0 | 42,2 | 19,1 | 30,0 |
| FBZ 25-3/4K | M25MSC3/4K | 25MO-1-12RT | 25 | 3/4 | 57,5 | 26,5 | 45,2 | 19,1 | 35,0 |
| FBZ 25-1K | M25MSC1K | 25MO-1-16RT | 25 | 1 | 62,3 | 26,5 | 50,0 | 23,9 | 35,0 |

NOTE: A and C dimensions are typical finger-tight.

Dimensions for reference only, subject to change.

Color Coding

For easy reference, table column headings are color indicated as follows:

fractional



metric



BSPP Male Connector For fractional tube

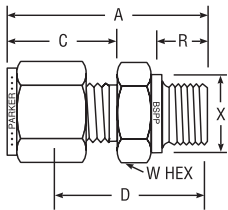
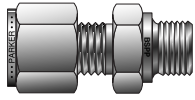

| CPI™ PART NO. | A-LOK® PART NO. | INTER- CHANGES WITH | INCHES | | | | | | | | | |
|------------------|--------------------|---------------------------|---------------|----------------|------|------|------|-----|------|----------|------|--|
| | | | TUBE O. D. | BSPP THREAD | A | C | D | R | X | W HEX | BORE | |
| 2-2R FBZ | 2MSC2R | 200-1-2RS | 1/8 | 1/8 | 1.18 | .60 | 0.92 | .28 | 0.54 | 9/16 | .16 | |
| 2-4R FBZ | 2MSC4R | 200-1-4RS | 1/8 | 1/4 | 1.27 | .60 | 1.13 | .44 | 0.70 | 3/4 | .09 | |
| 2-6R FBZ | 2MSC6R | 200-1-6RS | 1/8 | 3/8 | 1.46 | .60 | 1.17 | .44 | 0.86 | 7/8 | .28 | |
| 4-2R FBZ | 4MSC2R | 400-1-2RS | 1/4 | 1/8 | 1.28 | .70 | 0.98 | .28 | 0.54 | 9/16 | .16 | |
| 4-4R FBZ | 4MSC4R | 400-1-4RS | 1/4 | 1/4 | 1.49 | .70 | 1.19 | .44 | 0.70 | 3/4 | .19 | |
| 4-6R FBZ | 4MSC6R | 400-1-6RS | 1/4 | 3/8 | 1.55 | .70 | 1.25 | .44 | 0.86 | 7/8 | .19 | |
| 4-8R FBZ | 4MSC8R | 400-1-8RS | 1/4 | 1/2 | 1.77 | .70 | 1.47 | .56 | 1.01 | 1-1/16 | .19 | |
| 6-2R FBZ | 6MSC2R | 600-1-2RS | 3/8 | 1/8 | 1.35 | .76 | 1.06 | .28 | 0.54 | 5/8 | .16 | |
| 6-4R FBZ | 6MSC4R | 600-1-4RS | 3/8 | 1/4 | 1.54 | .76 | 1.25 | .44 | 0.70 | 3/4 | .25 | |
| 6-6R FBZ | 6MSC6R | 600-1-6RS | 3/8 | 3/8 | 1.57 | .76 | 1.28 | .44 | 0.86 | 7/8 | .28 | |
| 6-8R FBZ | 6MSC8R | 600-1-8RS | 3/8 | 1/2 | 1.82 | .76 | 1.53 | .56 | 1.01 | 1-1/16 | .28 | |
| 8-4R FBZ | 8MSC4R | 810-1-4RS | 1/2 | 1/4 | 1.66 | .86 | 1.28 | .44 | 0.70 | 13/16 | .25 | |
| 8-6R FBZ | 8MSC6R | 810-1-6RS | 1/2 | 3/8 | 1.69 | .86 | 1.31 | .44 | 0.86 | 7/8 | .31 | |
| 8-8R FBZ | 8MSC8R | 810-1-8RS | 1/2 | 1/2 | 1.91 | .86 | 1.53 | .56 | 1.01 | 1-1/16 | .41 | |
| 12-8R FBZ | 12MSC8R | 1210-1-8RS | 3/4 | 1/2 | 1.93 | .86 | 1.53 | .56 | 1.01 | 1-1/16 | .41 | |
| 12-12R FBZ | 12MSC12R | 1210-1-12RS | 3/4 | 3/4 | 2.07 | .86 | 1.69 | .63 | 1.25 | 1-3/8 | .63 | |
| 16-8R FBZ | 16MSC8R | 1610-1-8RS | 1 | 1/2 | 2.21 | 1.04 | 1.72 | .56 | 1.01 | 1-3/8 | .41 | |
| 16-16R FBZ | 16MSC16R | 1610-1-16RS | 1 | 1 | 2.35 | 1.04 | 1.88 | .72 | 1.52 | 1-5/8 | .88 | |

NOTE: A and C dimensions are typical finger-tight.

Dimensions for reference only, subject to change.

Sealing washer must be used with BSPP end shown ISO228/1 (Form A). See page 73.

For Form B undercut change part number and add B before R. e.g. M6MSC1/4BR.

BSPP Male Connector For metric tube

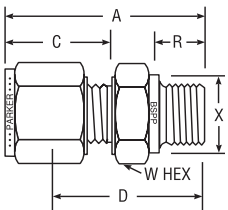
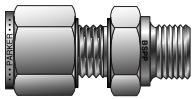

| CPI™ PART NO. | A-LOK® PART NO. | INTER-CHANGES WITH | MILLIMETERS | | | | | | | | | |
|------------------|--------------------|-----------------------|---------------|----------------|------|------|------|------|------|----------|------|--|
| | | | TUBE O. D. | BSPP THREAD | A | C | D | R | X | W HEX | | |
| FBZ 2-1/8R | M2MSC1/8R | 2MO-1-2RS | 2 | 1/8 | 28,4 | 15,3 | 21,8 | 7,1 | 14,0 | 13,7 | 13,7 | |
| FBZ 3-1/8R | M3MSC1/8R | 3MO-1-2RS | 3 | 1/8 | 30,0 | 15,3 | 23,4 | 7,1 | 13,7 | 14,0 | 14,0 | |
| FBZ 3-1/4R | M3MSC1/4R | 3MO-1-4RS | 3 | 1/4 | 35,3 | 15,3 | 28,7 | 11,2 | 17,8 | 19,0 | 19,0 | |
| FBZ 6-1/8R | M6MSC1/8R | 6MO-1-2RS | 6 | 1/8 | 32,5 | 17,7 | 25,0 | 7,1 | 13,7 | 14,0 | 14,0 | |
| FBZ 6-1/4R | M6MSC1/4R | 6MO-1-4RS | 6 | 1/4 | 37,7 | 17,7 | 30,2 | 11,2 | 17,8 | 19,0 | 19,0 | |
| FBZ 6-3/8R | M6MSC3/8R | 6MO-1-6RS | 6 | 3/8 | 39,0 | 17,7 | 31,5 | 11,2 | 21,8 | 22,0 | 22,0 | |
| FBZ 6-1/2R | M6MSC1/2R | 6MO-1-8RS | 6 | 1/2 | 45,6 | 17,7 | 38,1 | 14,2 | 25,7 | 27,0 | 27,0 | |
| FBZ 8-1/8R | M8MSC1/8R | 8MO-1-2RS | 8 | 1/8 | 33,1 | 18,6 | 25,6 | 7,1 | 15,0 | 13,7 | 13,7 | |
| FBZ 8-1/4R | M8MSC1/4R | 8MO-1-4RS | 8 | 1/4 | 38,5 | 18,6 | 31,0 | 11,2 | 17,8 | 19,0 | 19,0 | |
| FBZ 8-3/8R | M8MSC3/8R | 8MO-1-6RS | 8 | 3/8 | 39,8 | 18,6 | 32,3 | 11,2 | 21,8 | 22,0 | 22,0 | |
| FBZ 8-1/2R | M8MSC1/2R | 8MO-1-8RS | 8 | 1/2 | 45,6 | 18,6 | 38,1 | 14,2 | 25,7 | 27,0 | 27,0 | |
| FBZ 10-1/4R | M10MSC1/4R | 10MO-1-4RS | 10 | 1/4 | 39,4 | 19,5 | 31,8 | 11,2 | 17,8 | 19,0 | 19,0 | |
| FBZ 10-3/8R | M10MSC3/8R | 10MO-1-6RS | 10 | 3/8 | 40,6 | 19,5 | 33,0 | 11,2 | 21,8 | 22,0 | 22,0 | |
| FBZ 10-1/2R | M10MSC1/2R | 10MO-1-8RS | 10 | 1/2 | 46,5 | 19,5 | 38,9 | 14,2 | 25,7 | 27,0 | 27,0 | |
| FBZ 12-1/4R | M12MSC1/4R | 12MO-1-4RS | 12 | 1/4 | 42,6 | 22,0 | 32,5 | 11,2 | 17,8 | 22,0 | 22,0 | |
| FBZ 12-3/8R | M12MSC3/8R | 12MO-1-6RS | 12 | 3/8 | 43,1 | 22,0 | 33,0 | 11,2 | 21,8 | 22,0 | 22,0 | |
| FBZ 12-1/2R | M12MSC1/2R | 12MO-1-8RS | 12 | 1/2 | 49,0 | 22,0 | 38,9 | 14,2 | 25,7 | 27,0 | 27,0 | |
| FBZ 12-3/4R | M12MSC3/4R | 12MO-1-12RS | 12 | 3/4 | 52,8 | 22,0 | 42,7 | 16,0 | 31,8 | 35,0 | 35,0 | |
| FBZ 16-3/8R | M16MSC3/8R | 16MO-1-6RS | 16 | 3/8 | 43,5 | 22,0 | 33,4 | 11,2 | 22,0 | 21,8 | 21,8 | |
| FBZ 16-1/2R | M16MSC1/2R | 16MO-1-8RS | 16 | 1/2 | 49,0 | 22,0 | 38,9 | 14,2 | 26,0 | 27,0 | 27,0 | |
| FBZ 18-1/2R | M18MSC1/2R | 18MO-1-8RS | 18 | 1/2 | 49,0 | 22,0 | 38,9 | 14,2 | 26,0 | 27,0 | 27,0 | |
| FBZ 18-3/4R | M18MSC3/4R | 18MO-1-12RS | 18 | 3/4 | 53,1 | 22,0 | 43,0 | 16,0 | 35,0 | 32,0 | 32,0 | |
| FBZ 20-1/2R | M20MSC1/2R | 20MO-1-8RS | 20 | 1/2 | 50,5 | 22,0 | 40,4 | 14,2 | 30,0 | 25,7 | 25,7 | |
| FBZ 20-3/4R | M20MSC3/4R | 20MO-1-12RS | 20 | 3/4 | 52,8 | 22,0 | 42,7 | 16,0 | 32,0 | 35,0 | 35,0 | |
| FBZ 22-3/4R | M22MSC3/4R | 22MO-1-12RS | 22 | 3/4 | 52,8 | 22,0 | 42,7 | 16,0 | 32,0 | 35,0 | 35,0 | |
| FBZ 25-3/4R | M25MSC3/4R | 25MO-1-12RS | 25 | 3/4 | 59,8 | 26,5 | 47,6 | 16,0 | 35,0 | 31,8 | 31,8 | |
| FBZ 25-1R | M25MSC1R | 25MO-1-16RS | 25 | 1 | 60,1 | 26,5 | 47,8 | 18,3 | 39,0 | 41,0 | 41,0 | |

NOTE: A and C dimensions are typical finger-tight.

Dimensions for reference only, subject to change.

Sealing washer must be used with BSPP end shown ISO228/1 (Form A). See page 73.

For Form B undercut, add a "B" before the "R." e.g. M6MSC1/4BR.

BSPP Male Connector with ED Seal For fractional tube

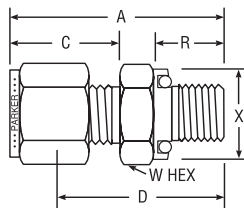
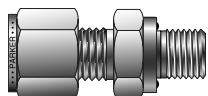

| CPI™ PART NO. | A-LOK® PART NO. | INTER- CHANGES WITH | INCHES | | | | | | | | |
|------------------|--------------------|---------------------------|--------------|----------------|------|-----|------|-----|------|----------|------|
| | | | TUBE O.D. | BSPP THREAD | A | C | D | R | X | W HEX | BORE |
| 4-4R-ED FBZ | 4MSC4R-ED | — | 1/4 | 1/4 | 1.48 | .70 | 1.19 | .47 | .74 | 3/4 | .19 |
| 4-8R-ED FBZ | 4MSC8R-ED | — | 1/4 | 1/2 | 1.76 | .70 | 1.38 | .55 | 1.04 | 1-1/16 | .19 |
| 6-6R-ED FBZ | 6MSC6R-ED | — | 3/8 | 3/8 | 1.60 | .76 | 1.31 | .47 | .86 | 7/8 | .28 |
| 8-4R-ED FBZ | 8MSC4R-ED | — | 1/2 | 1/4 | 1.69 | .86 | 1.31 | .47 | .74 | 13/16 | .25 |
| 8-6R-ED FBZ | 8MSC6R-ED | — | 1/2 | 3/8 | 1.69 | .86 | 1.31 | .47 | .86 | 7/8 | .31 |
| 8-8R-ED FBZ | 8MSC8R-ED | — | 1/2 | 1/2 | 1.85 | .86 | 1.47 | .55 | 1.04 | 1-1/16 | .41 |
| 12-12R-ED FBZ | 12MSC12R-ED | — | 3/4 | 3/4 | 1.98 | .86 | 1.59 | .63 | 1.25 | 1-5/16 | .63 |

NOTE: A and C dimensions are typical finger-tight.

Dimensions for reference only, subject to change.

ED fittings are supplied with sealing washers in nitrile as standard, suitable for temperatures of between -35°C and +100°C (-31°F to +212°F). Fluorocarbon seals are available upon request which are suitable for temperatures of between -25°C and +120°C (-13°F to +248°F).

Male Connector with ED Seal For metric tube

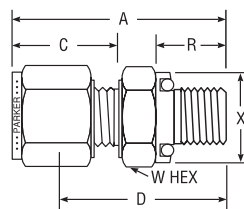
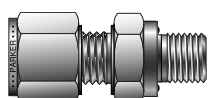

| CPI™ PART NO. | A-LOK® PART NO. | INTER- CHANGES WITH | MILLIMETERS | | | | | | | | |
|------------------|--------------------|---------------------------|--------------|----------------|------|------|------|------|------|----------|--|
| | | | TUBE O.D. | BSPP THREAD | A | C | D | R | X | W HEX | |
| FBZ6-1/8R-ED | M6MSC1/8R-ED | — | 6 | 1/8 | 32,5 | 17,7 | 25,0 | 7,9 | 13,7 | 14,0 | |
| FBZ6-1/4R-ED | M6MSC1/4R-ED | — | 6 | 1/4 | 38,2 | 17,7 | 30,7 | 11,9 | 18,8 | 19,0 | |
| FBZ6-3/8R-ED | M6MSC3/8R-ED | — | 6 | 3/8 | 39,5 | 17,7 | 32,0 | 11,9 | 21,8 | 22,0 | |
| FBZ6-1/2R-ED | M6MSC1/2R-ED | — | 6 | 1/2 | 44,5 | 17,7 | 37,0 | 14,0 | 26,4 | 27,0 | |
| FBZ10-1/4R-ED | M10MSC1/4R-ED | — | 10 | 1/4 | 40,0 | 19,5 | 32,3 | 11,9 | 18,8 | 19,0 | |
| FBZ10-3/8R-ED | M10MSC3/8R-ED | — | 10 | 3/8 | 41,1 | 19,5 | 38,1 | 11,9 | 21,8 | 22,0 | |
| FBZ10-1/2R-ED | M10MSC1/2R-ED | — | 10 | 1/2 | 46,0 | 19,5 | 38,4 | 14,0 | 26,4 | 27,0 | |
| FBZ12-1/4R-ED | M12MSC1/4R-ED | — | 12 | 1/4 | 43,1 | 22,0 | 33,0 | 11,9 | 18,8 | 22,0 | |
| FBZ12-3/8R-ED | M12MSC3/8R-ED | — | 12 | 3/8 | 43,6 | 22,0 | 33,5 | 11,9 | 21,8 | 22,0 | |
| FBZ12-1/2R-ED | M12MSC1/2R-ED | — | 12 | 1/2 | 48,5 | 22,0 | 38,4 | 14,0 | 26,4 | 27,0 | |

NOTE: A and C dimensions are typical finger-tight.

Dimensions for reference only, subject to change.

ED fittings are supplied with sealing washers in nitrile as standard, suitable for temperatures of between -35°C and +100°C (-31°F to +212°F). Fluorocarbon seals are available upon request which are suitable for temperatures of between -25°C and +120°C (-13°F to +248°F).

Color Coding

For easy reference, table column headings are color indicated as follows:

fractional



metric



NPT Male Bulkhead Connector For fractional tube

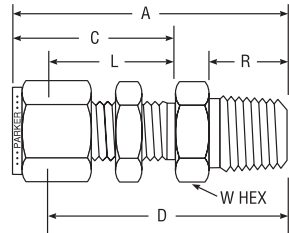
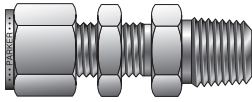

| CPI™ PART NO. | A-LOK® PART NO. | INTER- CHANGES WITH | INCHES | | | | | | | |
|------------------|--------------------|---------------------------|--------------|-----------------------|-------|------|-------|------|-----|----------|
| | | | TUBE O.D. | NPT PIPE THREAD | A | C | D | L | R | W HEX |
| 1-1 FH2BZ | 1MBC1N | 100-11-1 | 1/16 | 1/16 | 1.19 | 0.68 | 1.038 | .53 | .38 | 5/16 |
| 1-2 FH2BZ | 1MBC2N | 100-11-2 | 1/16 | 1/8 | 1.27 | 0.68 | 1.116 | .53 | .38 | 7/16 |
| 2-2 FH2BZ | 2MBC2N | 200-11-2 | 1/8 | 1/8 | 1.83 | 1.23 | 1.571 | .97 | .38 | 1/2 |
| 3-2 FH2BZ | 3MBC2N | 300-11-2 | 3/16 | 1/8 | 1.89 | 1.26 | 1.634 | 1.00 | .38 | 9/16 |
| 4-2 FH2BZ | 4MBC2N | 400-11-2 | 1/4 | 1/8 | 1.95 | 1.31 | 1.655 | 1.02 | .38 | 5/8 |
| 4-4 FH2BZ | 4MBC4N | 400-11-4 | 1/4 | 1/4 | 2.132 | 1.31 | 1.842 | 1.02 | .56 | 5/8 |
| 4-6 FH2BZ | 4MBC6N | 400-11-6 | 1/4 | 3/8 | 2.162 | 1.31 | 1.872 | 1.02 | .56 | 11/16 |
| 4-8 FH2BZ | 4MBC8N | 400-11-8 | 1/4 | 1/2 | 2.374 | 1.31 | 2.084 | 1.02 | .75 | 7/8 |
| 5-2 FH2BZ | 5MBC2N | 500-11-2 | 5/16 | 1/8 | 2.08 | 1.42 | 1.779 | 1.12 | .38 | 11/16 |
| 5-4 FH2BZ | 5MBC4N | 500-11-4 | 5/16 | 1/4 | 2.27 | 1.42 | 1.966 | 1.12 | .56 | 11/16 |
| 6-2 FH2BZ | 6MBC2N | 600-11-2 | 3/8 | 1/8 | 2.08 | 1.44 | 1.788 | 1.15 | .38 | 3/4 |
| 6-4 FH2BZ | 6MBC4N | 600-11-4 | 3/8 | 1/4 | 2.265 | 1.44 | 1.975 | 1.15 | .56 | 3/4 |
| 6-6 FH2BZ | 6MBC6N | 600-11-6 | 3/8 | 3/8 | 2.265 | 1.44 | 1.975 | 1.15 | .56 | 3/4 |
| 6-8 FH2BZ | 6MBC8N | 600-11-8 | 3/8 | 1/2 | 2.48 | 1.44 | 2.219 | 1.15 | .75 | 7/8 |
| 8-4 FH2BZ | 8MBC4N | 810-11-4 | 1/2 | 1/4 | 2.494 | 1.65 | 2.094 | 1.25 | .56 | 15/16 |
| 8-6 FH2BZ | 8MBC6N | 810-11-6 | 1/2 | 3/8 | 2.494 | 1.65 | 2.094 | 1.25 | .56 | 15/16 |
| 8-8 FH2BZ | 8MBC8N | 810-11-8 | 1/2 | 1/2 | 2.712 | 1.65 | 2.312 | 1.25 | .75 | 15/16 |
| 8-12 FH2BZ | 8MBC12N | 810-11-12 | 1/2 | 3/4 | 2.722 | 1.65 | 2.322 | 1.25 | .75 | 1-1/8 |
| 10-6 FH2BZ | 10MBC6N | 1010-11-6 | 5/8 | 3/8 | 2.628 | 1.68 | 2.228 | 1.28 | .56 | 1-1/16 |
| 10-8 FH2BZ | 10MBC8N | 1010-11-8 | 5/8 | 1/2 | 2.816 | 1.68 | 2.416 | 1.28 | .75 | 1-1/16 |
| 12-8 FH2BZ | 12MBC8N | 1210-11-8 | 3/4 | 1/2 | 3.00 | 1.87 | 2.601 | 1.47 | .75 | 1-3/16 |
| 12-12 FH2BZ | 12MBC12N | 1210-11-12 | 3/4 | 3/4 | 3.00 | 1.87 | 2.601 | 1.47 | .75 | 1-3/16 |
| 14-12 FH2BZ | 14MBC12N | 1410-11-12 | 7/8 | 3/4 | 3.31 | 2.09 | 2.913 | 1.69 | .75 | 1-3/8 |
| 16-12 FH2BZ | 16MBC12N | 1610-11-12 | 1 | 3/4 | 3.54 | 2.27 | 3.006 | 1.78 | .75 | 1-5/8 |
| 16-16 FH2BZ | 16MBC16N | 1610-11-16 | 1 | 1 | 3.72 | 2.27 | 3.194 | 1.78 | .94 | 1-5/8 |

NOTE: A and C dimensions are typical finger-tight.

Dimensions for reference only, subject to change.

For bulkhead hole drill size and maximum bulkhead thickness, see page 29, Part BC.

NPT Male Bulkhead Connector For metric tube

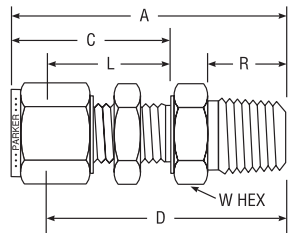
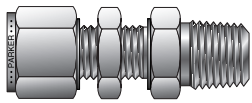

| CPI™ PART NO. | A-LOK® PART NO. | INTER- CHANGES WITH | MILLIMETERS | | | | | | | | | |
|------------------|--------------------|---------------------------|--------------|---------------|------|------|------|------|------|----------|---------------------------------|--------------------------|
| | | | TUBE O.D. | NPT THREAD | A | C | D | L | R | W HEX | B'HEAD HOLE DRILL SIZE | MAX. B'HEAD THICK. |
| FH2BZ 6-1/8 | M6MBC1/8N | 6MO-11-2 | 6 | 1/8 | 49,6 | 33,7 | 42,1 | 26,2 | 9,5 | 16,0 | 11,5 | 10,2 |
| FH2BZ 6-1/4 | M6MBC1/4N | 6MO-11-4 | 6 | 1/4 | 53,5 | 33,7 | 46,0 | 26,2 | 14,3 | 16,0 | 11,5 | 10,2 |
| FH2BZ 8-1/8 | M8MBC1/8N | 8MO-11-2 | 8 | 1/8 | 52,3 | 36,0 | 44,8 | 28,5 | 9,5 | 18,0 | 13,1 | 11,2 |
| FH2BZ 8-1/4 | M8MBC1/4N | 8MO-11-4 | 8 | 1/4 | 57,5 | 36,0 | 50,0 | 28,5 | 14,3 | 18,0 | 13,1 | 11,2 |
| FH2BZ 10-1/4 | M10MBC1/4N | 10MO-11-4 | 10 | 1/4 | 58,4 | 37,0 | 50,8 | 29,4 | 14,3 | 22,0 | 16,3 | 11,2 |
| FH2BZ 10-3/8 | M10MBC3/8N | 10MO-11-6 | 10 | 3/8 | 58,4 | 37,0 | 50,8 | 29,4 | 14,3 | 22,0 | 16,3 | 11,2 |
| FH2BZ 10-1/2 | M10MBC1/2N | 10MO-11-8 | 10 | 1/2 | 63,1 | 37,0 | 55,5 | 29,4 | 19,0 | 22,0 | 16,3 | 11,2 |
| FH2BZ 12-1/4 | M12MBC1/4N | 12MO-11-4 | 12 | 1/4 | 63,3 | 10,1 | 53,2 | 31,8 | 14,3 | 24,0 | 19,5 | 12,7 |
| FH2BZ 12-3/8 | M12MBC3/8N | 12MO-11-6 | 12 | 3/8 | 64,5 | 10,1 | 54,4 | 31,8 | 14,3 | 24,0 | 19,5 | 12,7 |
| FH2BZ 12-1/2 | M12MBC1/2N | 12MO-11-8 | 12 | 1/2 | 67,5 | 10,1 | 57,4 | 31,8 | 19,0 | 24,0 | 19,5 | 12,7 |

NOTE: A and C dimensions are typical finger-tight.

Dimensions for reference only, subject to change.

Thermocouple Connector For fractional tube

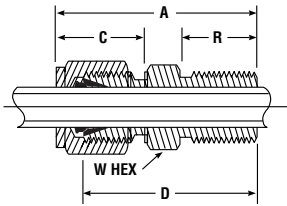
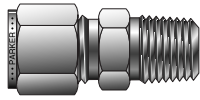

| CPI™ PART NO. | A-LOK® PART NO. | INTER- CHANGES WITH | INCHES | | | | | | |
|------------------|--------------------|---------------------------|---------------|--------------------|------|------|------|-----|----------|
| | | | TUBE O. D. | NPT PIPE THREAD | A | C | D | R | W HEX |
| 1-1 FH4BZ | 1MTC1N | 100-1-1BT | 1/16 | 1/16 | 0.93 | .43 | 0.78 | .38 | 5/16 |
| 1-2 FH4BZ | 1MTC2N | 100-1-2BT | 1/16 | 1/8 | 1.03 | .43 | 0.88 | .38 | 7/16 |
| 1-4 FH4BZ | 1MTC4N | 100-1-4BT | 1/16 | 1/4 | 1.23 | .43 | 1.08 | .56 | 9/16 |
| 2-1 FH4BZ | 2MTC1N | 200-1-1BT | 1/8 | 1/16 | 1.17 | .60 | 0.91 | .38 | 3/8 |
| 2-2 FH4BZ | 2MTC2N | 200-1-2BT | 1/8 | 1/8 | 1.20 | .60 | 0.94 | .38 | 7/16 |
| 2-4 FH4BZ | 2MTC4N | 200-1-4BT | 1/8 | 1/4 | 1.40 | .60 | 1.14 | .56 | 9/16 |
| 3-2 FH4BZ | 3MTC2N | 300-1-2BT | 3/16 | 1/8 | 1.23 | .64 | 0.97 | .38 | 7/16 |
| 3-4 FH4BZ | 3MTC4N | 300-1-4BT | 3/16 | 1/4 | 1.43 | .64 | 1.17 | .56 | 9/16 |
| 4-2 FH4BZ | 4MTC2N | 400-1-2BT | 1/4 | 1/8 | 1.29 | .70 | 1.00 | .38 | 1/2 |
| 4-4 FH4BZ | 4MTC4N | 400-1-4BT | 1/4 | 1/4 | 1.49 | .70 | 1.20 | .56 | 9/16 |
| 4-6 FH4BZ | 4MTC6N | 400-1-6BT | 1/4 | 3/8 | 1.60 | .70 | 1.22 | .56 | 11/16 |
| 4-8 FH4BZ | 4MTC8N | 400-1-8BT | 1/4 | 1/2 | 1.87 | .70 | 1.47 | .75 | 7/8 |
| 5-4 FH4BZ | 5MTC4N | 500-1-4BT | 5/16 | 1/4 | 1.52 | .73 | 1.22 | .56 | 9/16 |
| 6-4 FH4BZ | 6MTC4N | 600-1-4BT | 3/8 | 1/4 | 1.57 | .76 | 1.28 | .56 | 5/8 |
| 6-6 FH4BZ | 6MTC6N | 600-1-6BT | 3/8 | 3/8 | 1.57 | .76 | 1.28 | .56 | 11/16 |
| 6-8 FH4BZ | 6MTC8N | 600-1-8BT | 3/8 | 1/2 | 1.82 | .76 | 1.53 | .75 | 7/8 |
| 6-12 FH4BZ | 6MTC12N | 600-1-12BT | 3/8 | 3/4 | 1.88 | .76 | 1.59 | .75 | 1-1/16 |
| 8-8 FH4BZ | 8MTC8N | 810-1-8BT | 1/2 | 1/2 | 1.93 | .87 | 1.53 | .76 | 7/8 |
| 8-12 FH4BZ | 8MTC12N | 810-1-12BT | 1/2 | 3/4 | 1.99 | .87 | 1.59 | .75 | 1-1/16 |
| 10-12 FH4BZ | 10MTC12N | 1010-1-12BT | 5/8 | 3/4 | 1.99 | .87 | 1.59 | .75 | 1-1/16 |
| 12-12 FH4BZ | 12MTC12N | 1210-1-12BT | 3/4 | 3/4 | 1.99 | .87 | 1.59 | .75 | 1-1/16 |
| 16-16 FH4BZ | 16MTC16N | 1610-1-16BT | 1 | 1 | 2.46 | 1.05 | 1.97 | .94 | 1-3/8 |

NOTE: A and C dimensions are typical finger-tight.

Dimensions for reference only, subject to change.

NPT Male Elbow For fractional tube

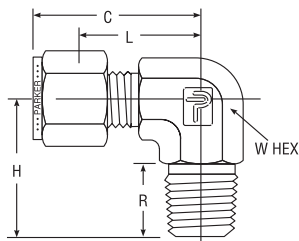
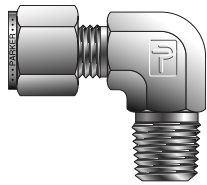

| CPI™ PART NO. | A-LOK® PART NO. | INTER- CHANGES WITH | INCHES | | | | | | |
|------------------|--------------------|---------------------------|---------------|--------------------|------|------|------|------|----------|
| | | | TUBE O. D. | NPT PIPE THREAD | C | H | L | R | W HEX |
| 1-1 CBZ | 1MSEL1N | 100-2-1 | 1/16 | 1/16 | .75 | 0.70 | .60 | .38 | 7/16 |
| 1-2 CBZ | 1MSEL2N | 100-2-2 | 1/16 | 1/8 | .75 | 0.70 | .60 | .38 | 7/16 |
| 2-1 CBZ | 2MSEL1N | 200-2-1 | 1/8 | 1/16 | .93 | 0.70 | .67 | .38 | 7/16 |
| 2-2 CBZ | 2MSEL2N | 200-2-2 | 1/8 | 1/8 | .93 | 0.70 | .67 | .38 | 7/16 |
| 2-4 CBZ | 2MSEL4N | 200-2-4 | 1/8 | 1/4 | .97 | 0.93 | .72 | .56 | 9/16 |
| 3-2 CBZ | 3MSEL2N | 300-2-2 | 3/16 | 1/8 | 1.00 | 0.74 | .74 | .38 | 1/2 |
| 3-4 CBZ | 3MSEL4N | 300-2-4 | 3/16 | 1/4 | 1.00 | 0.93 | .74 | .56 | 9/16 |
| 4-1 CBZ | 4MSEL1N | 400-2-1 | 1/4 | 1/16 | 1.06 | 0.74 | .77 | .38 | 1/2 |
| 4-2 CBZ | 4MSEL2N | 400-2-2 | 1/4 | 1/8 | 1.06 | 0.74 | .77 | .38 | 1/2 |
| 4-4 CBZ | 4MSEL4N | 400-2-4 | 1/4 | 1/4 | 1.06 | 0.93 | .77 | .56 | 9/16 |
| 4-6 CBZ | 4MSEL6N | 400-2-6 | 1/4 | 3/8 | 1.17 | 1.04 | .88 | .56 | 11/16 |
| 4-8 CBZ | 4MSEL8N | 400-2-8 | 1/4 | 1/2 | 1.25 | 1.31 | .96 | .75 | 13/16 |
| 5-2 CBZ | 5MSEL2N | 500-2-2 | 5/16 | 1/8 | 1.13 | 0.79 | .84 | .38 | 9/16 |
| 5-4 CBZ | 5MSEL4N | 500-2-4 | 5/16 | 1/4 | 1.13 | 0.97 | .84 | .56 | 9/16 |
| 6-2 CBZ | 6MSEL2N | 600-2-2 | 3/8 | 1/8 | 1.20 | 0.82 | .91 | .38 | 5/8 |
| 6-4 CBZ | 6MSEL4N | 600-2-4 | 3/8 | 1/4 | 1.20 | 1.01 | .91 | .56 | 5/8 |
| 6-6 CBZ | 6MSEL6N | 600-2-6 | 3/8 | 3/8 | 1.23 | 1.13 | .97 | .56 | 11/16 |
| 6-8 CBZ | 6MSEL8N | 600-2-8 | 3/8 | 1/2 | 1.31 | 1.31 | 1.02 | .75 | 13/16 |
| 6-12 CBZ | 6MSEL12N | 600-2-12 | 3/8 | 3/4 | 1.46 | 1.46 | 1.17 | .75 | 1-1/16 |
| 8-4 CBZ | 8MSEL4N | 810-2-4 | 1/2 | 1/4 | 1.42 | 1.12 | 1.02 | .56 | 13/16 |
| 8-6 CBZ | 8MSEL6N | 810-2-6 | 1/2 | 3/8 | 1.42 | 1.12 | 1.02 | .56 | 13/16 |
| 8-8 CBZ | 8MSEL8N | 810-2-8 | 1/2 | 1/2 | 1.42 | 1.31 | 1.02 | .75 | 13/16 |
| 8-12 CBZ | 8MSEL12N | 810-2-12 | 1/2 | 3/4 | 1.57 | 1.46 | 1.17 | .75 | 1-1/16 |
| 10-6 CBZ | 10MSEL6N | 1010-2-6 | 5/8 | 3/8 | 1.50 | 1.20 | 1.10 | .56 | 15/16 |
| 10-8 CBZ | 10MSEL8N | 1010-2-8 | 5/8 | 1/2 | 1.50 | 1.39 | 1.10 | .75 | 15/16 |
| 10-12 CBZ | 10MSEL12N | 1010-2-12 | 5/8 | 3/4 | 1.57 | 1.46 | 1.17 | .75 | 1-1/16 |
| 12-8 CBZ | 12MSEL8N | 1210-2-8 | 3/4 | 1/2 | 1.57 | 1.46 | 1.17 | .75 | 1-1/16 |
| 12-12 CBZ | 12MSEL12N | 1210-2-12 | 3/4 | 3/4 | 1.57 | 1.46 | 1.17 | .75 | 1-1/16 |
| 14-12 CBZ | 14MSEL12N | 1410-2-12 | 7/8 | 3/4 | 1.76 | 1.65 | 1.36 | .75 | 1-3/8 |
| 16-12 CBZ | 16MSEL12N | 1610-2-12 | 1 | 3/4 | 1.93 | 1.65 | 1.45 | .75 | 1-3/8 |
| 16-16 CBZ | 16MSEL16N | 1610-2-16 | 1 | 1 | 1.93 | 1.84 | 1.45 | .94 | 1-3/8 |
| 20-20 CBZ | 20MSEL20N | 2010-2-20 | 1-1/4 | 1-1/4 | 2.61 | 1.88 | 1.75 | .97 | 1-5/8 |
| 24-24 CBZ | 24MSEL24N | 2410-2-24 | 1-1/2 | 1-1/2 | 3.06 | 2.38 | 2.00 | 1.00 | 1-7/8 |
| 32-32 CBZ | 32MSEL32N | 3200-2-32 | 2 | 2 | 4.22 | 2.79 | 2.75 | 1.04 | 2-13/16 |

NOTE: C dimension is typical finger-tight.

Dimensions for reference only, subject to change.

Sizes 20, 24 require additional lubrication prior to assembly.

Color Coding

For easy reference, table column headings are color indicated as follows:

fractional

metric



NPT Male Metric Elbow

For metric tube

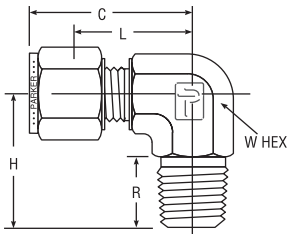
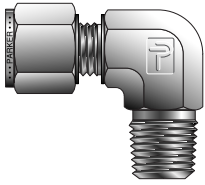

| CPI™ PART NO. | A-LOK® PART NO. | INTER- CHANGES WITH | MILLIMETERS | | | | | | INCHES |
|------------------|--------------------|---------------------------|---------------|---------------|------|------|------|------|----------|
| | | | TUBE O. D. | NPT THREAD | C | H | L | R | W HEX |
| CBZ 3-1/8 | M3MSEL1/8N | 3MO-2-2 | 3 | 1/8 | 23,6 | 17,8 | 17,0 | 9,7 | 7/16 |
| CBZ 3-1/4 | M3MSEL1/4N | 3MO-2-4 | 3 | 1/4 | 24,6 | 23,4 | 18,0 | 14,2 | 1/2 |
| CBZ 4-1/8 | M4MSEL1/8N | 4MO-2-2 | 4 | 1/8 | 25,4 | 18,8 | 19,2 | 9,7 | 1/2 |
| CBZ 4-1/4 | M4MSEL1/4N | 4MO-2-4 | 4 | 1/4 | 26,2 | 25,4 | 19,6 | 14,2 | 1/2 |
| CBZ 6-1/8 | M6MSEL1/8N | 6MO-2-2 | 6 | 1/8 | 27,0 | 18,8 | 19,6 | 9,7 | 1/2 |
| CBZ 6-1/4 | M6MSEL1/4N | 6MO-2-4 | 6 | 1/4 | 27,0 | 23,4 | 19,6 | 14,2 | 1/2 |
| CBZ 6-3/8 | M6MSEL3/8N | 6MO-2-6 | 6 | 3/8 | 29,8 | 26,2 | 22,4 | 14,2 | 11/16 |
| CBZ 6-1/2 | M6MSEL1/2N | 6MO-2-8 | 6 | 1/2 | 31,8 | 33,0 | 24,4 | 19,0 | 13/16 |
| CBZ 8-1/8 | M8MSEL1/8N | 8MO-2-2 | 8 | 1/8 | 28,8 | 19,8 | 21,3 | 9,7 | 9/16 |
| CBZ 8-1/4 | M8MSEL1/4N | 8MO-2-4 | 8 | 1/4 | 28,8 | 24,4 | 21,3 | 14,2 | 9/16 |
| CBZ 8-3/8 | M8MSEL3/8N | 8MO-2-6 | 8 | 3/8 | 30,6 | 26,2 | 23,1 | 14,2 | 11/16 |
| CBZ 8-1/2 | M8MSEL1/2N | 8MO-2-8 | 8 | 1/2 | 32,7 | 33,0 | 25,2 | 19,1 | 13/16 |
| CBZ 10-1/8 | M10MSEL1/8N | 10MO-2-8 | 10 | 1/8 | 31,5 | 21,6 | 23,9 | 9,7 | 11/16 |
| CBZ 10-1/4 | M10MSEL1/4N | 10MO-2-4 | 10 | 1/4 | 31,5 | 26,2 | 23,9 | 14,2 | 11/16 |
| CBZ 10-3/8 | M10MSEL3/8N | 10MO-2-6 | 10 | 3/8 | 31,5 | 26,2 | 23,9 | 14,2 | 11/16 |
| CBZ 10-1/2 | M10MSEL1/2N | 10MO-2-8 | 10 | 1/2 | 33,5 | 33,0 | 25,9 | 19,0 | 13/16 |
| CBZ 12-1/4 | M12MSEL1/4N | 12MO-2-4 | 12 | 1/4 | 36,0 | 28,2 | 25,9 | 14,2 | 13/16 |
| CBZ 12-3/8 | M12MSEL3/8N | 12MO-2-6 | 12 | 3/8 | 36,0 | 28,2 | 25,9 | 14,2 | 13/16 |
| CBZ 12-1/2 | M12MSEL1/2N | 12MO-2-8 | 12 | 1/2 | 36,0 | 33,0 | 25,9 | 19,0 | 13/16 |
| CBZ 12-3/4 | M12MSEL3/4N | 12MO-2-12 | 12 | 3/4 | 39,8 | 36,8 | 29,7 | 19,0 | 1-1/16 |
| CBZ 15-1/2 | M15MSEL1/2N | 15MO-2-8 | 15 | 1/2 | 38,0 | 35,1 | 27,9 | 19,0 | 15/16 |
| CBZ 16-3/8 | M16MSEL3/8N | 16MO-2-6 | 16 | 3/8 | 38,0 | 30,2 | 27,9 | 14,2 | 15/16 |
| CBZ 16-1/2 | M16MSEL1/2N | 16MO-2-8 | 16 | 1/2 | 38,0 | 35,1 | 27,9 | 19,0 | 15/16 |
| CBZ 16-3/4 | M16MSEL3/4N | 16MO-2-12 | 16 | 3/4 | 39,8 | 36,8 | 29,7 | 19,0 | 1-1/16 |
| CBZ 18-1/2 | M18MSEL1/2N | 18MO-2-8 | 18 | 1/2 | 39,8 | 36,8 | 29,7 | 19,0 | 1-1/16 |
| CBZ 18-3/4 | M18MSEL3/4N | 18MO-2-12 | 18 | 3/4 | 39,8 | 36,8 | 29,7 | 19,0 | 1-1/16 |
| CBZ 20-1/2 | M20MSEL1/2N | 20MO-2-8 | 20 | 1/2 | 44,6 | 41,7 | 34,5 | 19,0 | 1-3/8 |
| CBZ 20-3/4 | M20MSEL3/4N | 20MO-2-12 | 20 | 3/4 | 44,6 | 41,7 | 34,5 | 19,0 | 1-3/8 |
| CBZ 22-3/4 | M22MSEL3/4N | 22MO-2-12 | 22 | 3/4 | 44,6 | 41,7 | 34,5 | 19,0 | 1-3/8 |
| CBZ 25-3/4 | M25MSEL3/4N | 25MO-2-12 | 25 | 3/4 | 49,1 | 41,7 | 36,8 | 19,0 | 1-3/8 |
| CBZ 25-1 | M25MSEL1N | 25MO-2-16 | 25 | 1 | 49,1 | 46,5 | 36,8 | 23,9 | 1-3/8 |

NOTE: C dimension is typical finger-tight.

Dimensions for reference only, subject to change.

BSP Taper Male Elbow

For fractional tube

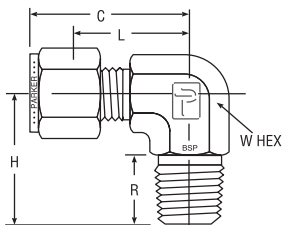
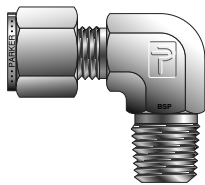

| CPI™ PART NO. | A-LOK® PART NO. | INTER- CHANGES WITH | INCHES | | | | | | |
|------------------|--------------------|---------------------------|---------------|----------------|------|------|------|-----|----------|
| | | | TUBE O. D. | BSPT THREAD | C | H | L | R | W HEX |
| 4-2K CBZ | 4MSEL2K | 400-2-2RT | 1/4 | 1/8 | 1.06 | 0.75 | 0.77 | .38 | 1/2 |
| 4-4K CBZ | 4MSEL4K | 400-2-4RT | 1/4 | 1/4 | 1.06 | 0.94 | 0.77 | .56 | 9/16 |
| 4-6K CBZ | 4MSEL6K | 400-2-6RT | 1/4 | 3/8 | 1.17 | 1.05 | 0.88 | .56 | 11/16 |
| 4-8K CBZ | 4MSEL8K | 400-2-8RT | 1/4 | 1/2 | 1.25 | 1.32 | 0.96 | .75 | 13/16 |
| 5-4K CBZ | 5MSEL4K | 500-2-4RT | 5/16 | 1/4 | 1.13 | 0.98 | 0.84 | .38 | 9/16 |
| 6-4K CBZ | 6MSEL4K | 600-2-4RT | 3/8 | 1/4 | 1.20 | 1.02 | 0.91 | .56 | 5/8 |
| 6-6K CBZ | 6MSEL6K | 600-2-4RT | 3/8 | 3/8 | 1.23 | 1.05 | 0.97 | .56 | 11/16 |
| 8-6K CBZ | 8MSEL6K | 810-2-6RT | 1/2 | 3/8 | 1.42 | 1.13 | 1.02 | .56 | 13/16 |
| 8-8K CBZ | 8MSEL8K | 810-2-8RT | 1/2 | 1/2 | 1.42 | 1.32 | 1.02 | .75 | 13/16 |

NOTE: C dimension is typical finger-tight.

Dimensions for reference only, subject to change.

BSP Taper Male Elbow

For metric tube

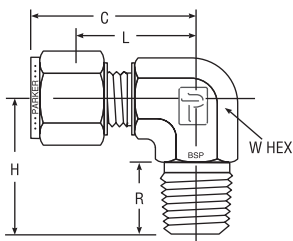
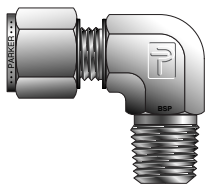

| CPI™ PART NO. | A-LOK® PART NO. | INTER- CHANGES WITH | MILLIMETERS | | | | | INCHES | |
|------------------|--------------------|---------------------------|--------------|----------------|------|------|------|--------|----------|
| | | | TUBE O.D. | BSPT THREAD | C | H | L | R | W HEX |
| CBZ 3-1/8K | M3MSEL1/8K | 3MO-2-2RT | 3 | 1/8 | 23,6 | 17,8 | 17,0 | 9,7 | 7/16 |
| CBZ 3-1/4K | M3MSEL1/4K | 3MO-2-4RT | 3 | 1/4 | 24,6 | 23,4 | 18,0 | 14,2 | 1/2 |
| CBZ 4-1/8K | M4MSEL1/8K | 4MO-2-2RT | 4 | 1/8 | 25,4 | 18,8 | 18,8 | 9,7 | 1/2 |
| CBZ 4-1/4K | M4MSEL1/4K | 4MO-2-4RT | 4 | 1/4 | 24,6 | 23,4 | 18,8 | 14,2 | 1/2 |
| CBZ 6-1/8K | M6MSEL1/8K | 6MO-2-2RT | 6 | 1/8 | 27,0 | 18,8 | 19,6 | 9,7 | 1/2 |
| CBZ 6-1/4K | M6MSEL1/4K | 6MO-2-4RT | 6 | 1/4 | 27,0 | 23,4 | 19,6 | 14,2 | 1/2 |
| CBZ 6-3/8K | M6MSEL3/8K | 6MO-2-6RT | 6 | 3/8 | 29,8 | 26,2 | 22,4 | 14,2 | 11/16 |
| CBZ 6-1/2K | M6MSEL1/2K | 6MO-2-8RT | 6 | 1/2 | 31,8 | 33,0 | 24,4 | 19,0 | 13/16 |
| CBZ 8-1/8K | M8MSEL1/8K | 8MO-2-2RT | 8 | 1/8 | 28,8 | 19,8 | 21,3 | 9,7 | 9/16 |
| CBZ 8-1/4K | M8MSEL1/4K | 8MO-2-4RT | 8 | 1/4 | 28,8 | 24,4 | 21,3 | 14,2 | 9/16 |
| CBZ 8-3/8K | M8MSEL3/8K | 8MO-2-6RT | 8 | 3/8 | 30,6 | 26,2 | 23,1 | 14,2 | 11/16 |
| CBZ 8-1/2K | M8MSEL1/2K | 8MO-2-8RT | 8 | 1/2 | 32,7 | 33,0 | 25,2 | 19,1 | 13/16 |
| CBZ 10-1/8K | M10MSEL1/8K | 10MO-2-2RT | 10 | 1/8 | 31,5 | 21,6 | 23,9 | 9,7 | 11/16 |
| CBZ 10-1/4K | M10MSEL1/4K | 10MO-2-4RT | 10 | 1/4 | 31,5 | 26,2 | 23,9 | 14,2 | 11/16 |
| CBZ 10-3/8K | M10MSEL3/8K | 10MO-2-6RT | 10 | 3/8 | 31,5 | 26,2 | 23,9 | 14,2 | 11/16 |
| CBZ 10-1/2K | M10MSEL1/2K | 10MO-2-8RT | 10 | 1/2 | 33,5 | 33,0 | 25,9 | 19,0 | 13/16 |
| CBZ 12-1/4K | M12MSEL1/4K | 12MO-2-4RT | 12 | 1/4 | 36,0 | 28,2 | 25,9 | 14,2 | 13/16 |
| CBZ 12-3/8K | M12MSEL3/8K | 12MO-2-6RT | 12 | 3/8 | 36,0 | 28,2 | 25,9 | 14,2 | 13/16 |
| CBZ 12-1/2K | M12MSEL1/2K | 12MO-2-8RT | 12 | 1/2 | 36,0 | 33,0 | 25,9 | 19,0 | 13/16 |
| CBZ 12-3/4K | M12MSEL3/4K | 12MO-2-12RT | 12 | 3/4 | 39,8 | 36,8 | 29,7 | 19,1 | 1-1/16 |
| CBZ 16-3/8K | M16MSEL3/8K | 16MO-2-6RT | 16 | 3/8 | 38,0 | 30,2 | 27,9 | 14,2 | 15/16 |
| CBZ 16-1/2K | M16MSEL1/2K | 16MO-2-8RT | 16 | 1/2 | 38,0 | 35,1 | 27,9 | 19,0 | 15/16 |
| CBZ 18-1/2K | M18MSEL1/2K | 18MO-2-8RT | 18 | 1/2 | 39,8 | 36,8 | 29,7 | 19,0 | 1-1/16 |
| CBZ 18-3/4K | M18MSEL3/4K | 18MO-2-12RT | 18 | 3/4 | 39,8 | 36,8 | 29,7 | 19,0 | 1-1/16 |
| CBZ 20-3/4K | M20MSEL3/4K | 20MO-2-12RT | 20 | 3/4 | 44,6 | 41,7 | 34,5 | 19,0 | 1-3/8 |
| CBZ 25-3/4K | M25MSEL3/4K | 25MO-2-12RT | 25 | 3/4 | 49,0 | 41,7 | 36,8 | 19,1 | 1-3/8 |
| CBZ 25-1K | M25MSEL1K | 25MO-2-16RT | 25 | 1 | 49,1 | 46,5 | 36,8 | 23,9 | 1-3/8 |

NOTE: C dimension is typical finger-tight.

Dimensions for reference only, subject to change.

Color Coding

For easy reference, table column headings are color indicated as follows:

fractional



metric



NPT Male 45° Elbow For fractional tube

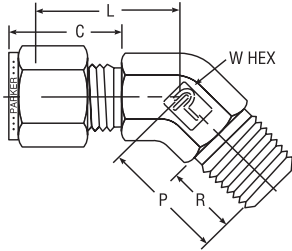
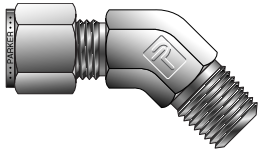

| CPI™ PART NO. | A-LOK® PART NO. | INTER- CHANGES WITH | INCHES | | | | | | |
|------------------|--------------------|---------------------------|---------------|--------------------|------|------|------|-----|----------|
| | | | TUBE O. D. | NPT PIPE THREAD | C | L | P | R | W HEX |
| 1-1 VBZ | 1MVEL1N | 100-5-1 | 1/16 | 1/16 | 0.43 | 0.47 | 0.57 | .38 | 7/16 |
| 2-2 VBZ | 2MVEL2N | 200-5-2 | 1/8 | 1/8 | 0.60 | 0.53 | 0.57 | .38 | 7/16 |
| 3-2 VBZ | 3MVEL2N | 300-5-2 | 3/16 | 1/8 | 0.64 | 0.56 | 0.58 | .38 | 7/16 |
| 4-2 VBZ | 4MVEL2N | 400-5-2 | 1/4 | 1/8 | 0.70 | 0.66 | 0.66 | .38 | 9/16 |
| 4-4 VBZ | 4MVEL4N | 400-5-4 | 1/4 | 1/4 | 0.70 | 0.66 | 0.86 | .56 | 9/16 |
| 5-2 VBZ | 5MVEL2N | 500-5-2 | 5/16 | 1/8 | 0.73 | 0.66 | 0.66 | .38 | 9/16 |
| 6-2 VBZ | 6MVEL2N | 600-5-2 | 3/8 | 1/8 | 0.76 | 0.72 | 0.67 | .38 | 9/16 |
| 6-4 VBZ | 6MVEL4N | 600-5-4 | 3/8 | 1/4 | 0.76 | 0.72 | 0.86 | .56 | 9/16 |
| 6-6 VBZ | 6MVEL6N | 600-5-6 | 3/8 | 3/8 | 0.76 | 0.75 | 0.95 | .56 | 3/4 |
| 8-6 VBZ | 8MVEL6N | 810-5-6 | 1/2 | 3/8 | 0.87 | 0.75 | 0.95 | .56 | 3/4 |
| 10-8 VBZ | 10MVEL8N | 1010-5-8 | 5/8 | 1/2 | 0.87 | 0.84 | 1.20 | .75 | 1-1/16 |
| 12-12 VBZ | 12MVEL12N | 1210-5-12 | 3/4 | 3/4 | 0.87 | 0.84 | 1.20 | .75 | 1-1/16 |
| 14-12 VBZ | 14MVEL12N | 1410-5-8 | 7/8 | 3/4 | 0.87 | 1.36 | 1.27 | .75 | 1-5/16 |
| 16-16 VBZ | 16MVEL16N | 1610-5-8 | 1 | 1 | 1.05 | 1.19 | 1.14 | .94 | 1-5/16 |

NOTE: C dimension is typical finger-tight.

Dimensions for reference only, subject to change.

NPT Male 45° Elbow For metric tube

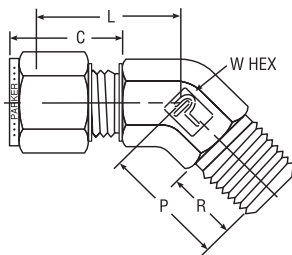
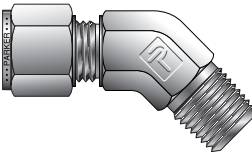

| CPI™ PART NO. | A-LOK® PART NO. | INTER- CHANGES WITH | MILLIMETERS | | | | | | |
|------------------|--------------------|---------------------------|---------------|--------------------|------|------|------|------|----------|
| | | | TUBE O. D. | NPT PIPE THREAD | C | L | P | R | W HEX |
| VBZ 6-1/8 | M6MVEL1/8N | — | 6 | 1/8 | 17,7 | 16,0 | 16,8 | 9,5 | 14,0 |
| VBZ 6-1/4 | M6MVEL1/4N | — | 6 | 1/4 | 17,7 | 16,0 | 21,8 | 14,3 | 14,0 |
| VBZ 8-1/8 | M8MVEL1/8N | — | 8 | 1/8 | 18,6 | 16,8 | 16,8 | 9,5 | 14,0 |
| VBZ 10-1/4 | M10MVEL1/4N | — | 10 | 1/4 | 19,5 | 19,0 | 24,1 | 14,3 | 19,0 |
| VBZ 12-3/8 | M12MVEL3/8N | — | 12 | 3/8 | 22,0 | 19,0 | 24,1 | 14,3 | 19,0 |
| VBZ 12-1/2 | M12MVEL1/2N | — | 12 | 1/2 | 22,0 | 20,6 | 29,7 | 19,0 | 22,0 |
| VBZ 16-1/2 | M16MVEL1/2N | — | 16 | 1/2 | 22,0 | 20,6 | 29,7 | 19,0 | 22,0 |

NOTE: C dimension is typical finger-tight.

Dimensions for reference only, subject to change.

NPT Male Run Tee

For fractional tube

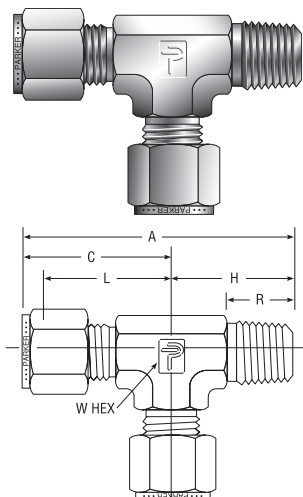

| CPI™ PART NO. | A-LOK® PART NO. | INTER- CHANGES WITH | INCHES | | | | | | | |
|------------------|--------------------|---------------------------|--------------|-----------------------|------|------|------|------|-----|----------|
| | | | TUBE O.D. | NPT PIPE THREAD | A | C | H | L | R | W HEX |
| 2-2-2 RBZ | 2MRT2N | 200-3-2TMT | 1/8 | 1/8 | 1.63 | 0.93 | 0.71 | 0.66 | .38 | 7/16 |
| 2-4-2 RBZ | 2MRT4N | 200-3-4TMT | 1/8 | 1/4 | 1.89 | 0.97 | 0.93 | 0.70 | .56 | 9/16 |
| 3-2-3 RBZ | 3MRT2N | 300-3-2TMT | 3/16 | 1/8 | 1.66 | 0.96 | 0.70 | 0.70 | .38 | 7/16 |
| 4-2-4 RBZ | 4MRT2N | 400-3-2TMT | 1/4 | 1/8 | 1.80 | 1.06 | 0.74 | 0.77 | .38 | 1/2 |
| 4-4-4 RBZ | 4MRT4N | 400-3-4TMT | 1/4 | 1/4 | 1.98 | 1.06 | 0.93 | 0.77 | .56 | 1/2 |
| 5-2-5 RBZ | 5MRT2N | 500-3-2TMT | 5/16 | 1/8 | 1.99 | 1.17 | 0.82 | 0.88 | .38 | 5/8 |
| 5-4-5 RBZ | 5MRT4N | 500-3-4TMT | 5/16 | 1/4 | 2.18 | 1.17 | 1.01 | 0.88 | .56 | 5/8 |
| 6-4-6 RBZ | 6MRT4N | 600-3-4TMT | 3/8 | 1/4 | 2.20 | 1.20 | 1.01 | 0.91 | .56 | 5/8 |
| 6-6-6 RBZ | 6MRT6N | 600-3-6TMT | 3/8 | 3/8 | 2.42 | 1.31 | 1.12 | 1.02 | .56 | 13/16 |
| 8-6-8 RBZ | 8MRT6N | 810-3-6TMT | 1/2 | 3/8 | 2.53 | 1.42 | 1.12 | 1.02 | .56 | 13/16 |
| 8-8-8 RBZ | 8MRT8N | 810-3-8TMT | 1/2 | 1/2 | 2.72 | 1.42 | 1.31 | 1.02 | .75 | 7/8 |
| 10-8-10 RBZ | 10MRT8N | 1010-3-8TMT | 5/8 | 1/2 | 2.88 | 1.50 | 1.39 | 1.10 | .75 | 15/16 |
| 12-12-12 RBZ | 12MRT12N | 1210-3-12TMT | 3/4 | 3/4 | 3.02 | 1.57 | 1.46 | 1.17 | .75 | 1-1/16 |
| 14-12-14 RBZ | 14MRT12N | 1410-3-12TMT | 7/8 | 3/4 | 3.41 | 1.76 | 1.65 | 1.36 | .75 | 1-3/8 |
| 16-12-16 RBZ | 16MRT12N | 1610-3-12TMT | 1 | 3/4 | 3.59 | 1.94 | 1.65 | 1.45 | .75 | 1-3/8 |
| 16-16-16 RBZ | 16MRT16N | 1610-3-16TMT | 1 | 1 | 3.78 | 1.94 | 1.84 | 1.45 | .94 | 1-3/8 |

NOTE: A and C dimensions are typical finger-tight.

Dimensions for reference only, subject to change.

NPT Male Run Tee

For metric tube

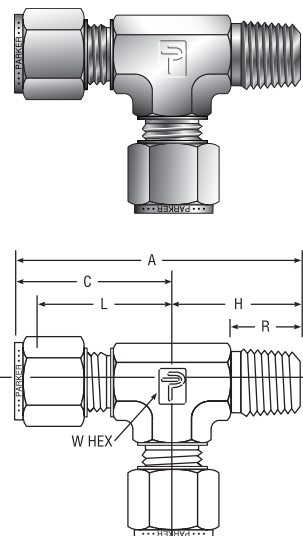

| CPI™ PART NO. | A-LOK® PART NO. | INTER- CHANGES WITH | MILLIMETERS | | | | | | | INCHES |
|------------------|--------------------|---------------------------|--------------|---------------|------|------|------|------|------|----------|
| | | | TUBE O.D. | NPT THREAD | A | C | H | L | R | W HEX |
| RBZ 6-1/8-6 | M6MRT1/8N | 6MO-3-2TMT | 6 | 1/8 | 45,8 | 27,0 | 18,0 | 19,6 | 9,7 | 1/2 |
| RBZ 6-1/4-6 | M6MRT1/4N | 6MO-3-4TMT | 6 | 1/4 | 50,3 | 27,0 | 23,4 | 19,6 | 14,2 | 1/2 |
| RBZ 8-1/8-8 | M8MRT1/8N | 8MO-3-2TMT | 8 | 1/8 | 50,7 | 29,9 | 20,8 | 22,4 | 9,7 | 5/8 |
| RBZ 8-1/4-8 | M8MRT1/4N | 8MO-3-4TMT | 8 | 1/4 | 55,3 | 29,9 | 25,4 | 22,4 | 14,2 | 5/8 |
| RBZ 10-1/4-10 | M10MRT1/4N | 10MO-3-4TMT | 10 | 1/4 | 61,7 | 33,5 | 28,2 | 25,9 | 14,2 | 13/16 |
| RBZ 10-1/2-10 | M10MRT1/2N | 10MO-3-8TMT | 10 | 1/2 | 66,5 | 33,5 | 33,0 | 25,9 | 19,0 | 13/16 |
| RBZ 12-1/4-12 | M12MRT1/4N | 12MO-3-4TMT | 12 | 1/4 | 64,2 | 36,0 | 28,2 | 25,9 | 14,2 | 13/16 |
| RBZ 12-3/8-12 | M12MRT3/8N | 12MO-3-6TMT | 12 | 3/8 | 64,2 | 36,0 | 28,2 | 25,9 | 14,2 | 13/16 |
| RBZ 12-1/2-12 | M12MRT1/2N | 12MO-3-8TMT | 12 | 1/2 | 69,0 | 36,0 | 33,0 | 25,9 | 19,0 | 13/16 |
| RBZ 16-1-16 | M16MRT1N | 16MO-3-16TMT | 16 | 1 | 93,1 | 46,6 | 46,5 | 34,4 | 23,9 | 1-3/8 |

NOTE: A and C dimensions are typical finger-tight.

Dimensions for reference only, subject to change.

Color Coding

For easy reference, table column headings are color indicated as follows:

fractional



metric



NPT Male Branch Tee

For fractional tube

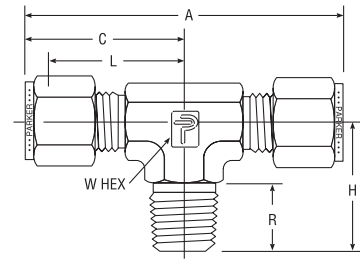
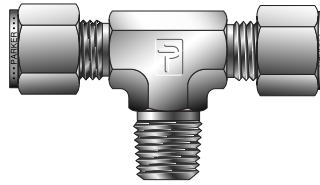

| CPI™ PART NO. | A-LOK® PART NO. | INTER- CHANGES WITH | INCHES | | | | | | | |
|------------------|--------------------|---------------------------|---------------|-----------------------|------|------|------|------|-----|----------|
| | | | TUBE O. D. | NPT PIPE THREAD | A | C | H | L | R | W HEX |
| 2-2-2 SBZ | 2MBT2N | 200-3-2TTM | 1/8 | 1/8 | 1.84 | 0.92 | 0.70 | 0.66 | .38 | 7/16 |
| 2-2-4 SBZ | 2MBT4N | 200-3-4TTM | 1/8 | 1/4 | 1.96 | 0.98 | 0.93 | 0.72 | .56 | 1/2 |
| 3-3-2 SBZ | 3MBT2N | 300-3-2TTM | 3/16 | 1/8 | 2.00 | 1.00 | 0.74 | 0.74 | .38 | 1/2 |
| 4-4-2 SBZ | 4MBT2N | 400-3-2TTM | 1/4 | 1/8 | 2.12 | 1.06 | 0.74 | 0.77 | .38 | 1/2 |
| 4-4-4 SBZ | 4MBT4N | 400-3-4TTM | 1/4 | 1/4 | 2.12 | 1.07 | 0.93 | 0.77 | .56 | 1/2 |
| 5-5-2 SBZ | 5MBT2N | 500-3-2TTM | 5/16 | 1/8 | 2.34 | 1.17 | 0.82 | 0.88 | .38 | 5/8 |
| 5-5-4 SBZ | 5MBT4N | 500-3-4TTM | 5/16 | 1/4 | 2.34 | 1.17 | 1.01 | 0.88 | .56 | 5/8 |
| 6-6-4 SBZ | 6MBT4N | 600-3-4TTM | 3/8 | 1/4 | 2.40 | 1.20 | 1.01 | 0.91 | .56 | 5/8 |
| 6-6-6 SBZ | 6MBT6N | 600-3-6TTM | 3/8 | 3/8 | 2.62 | 1.31 | 1.12 | 1.02 | .56 | 13/16 |
| 8-8-6 SBZ | 8MBT6N | 810-3-6TTM | 1/2 | 3/8 | 2.84 | 1.42 | 1.12 | 1.02 | .56 | 13/16 |
| 8-8-8 SBZ | 8MBT8N | 810-3-8TTM | 1/2 | 1/2 | 2.86 | 1.43 | 1.31 | 1.03 | .75 | 7/8 |
| 10-10-8 SBZ | 10MBT8N | 1010-3-8TTM | 5/8 | 1/2 | 2.86 | 1.53 | 1.42 | 1.13 | .75 | 1 |
| 12-12-12 SBZ | 12MBT12N | 1210-3-12TTM | 3/4 | 3/4 | 3.14 | 1.57 | 1.46 | 1.17 | .75 | 1-1/16 |
| 14-14-12 SBZ | 14MBT12N | 1410-3-12TTM | 7/8 | 3/4 | 3.52 | 1.76 | 1.65 | 1.36 | .75 | 1-3/8 |
| 16-16-12 SBZ | 16MBT12N | 1610-3-12TTM | 1 | 3/4 | 3.88 | 1.94 | 1.65 | 1.45 | .75 | 1-3/8 |
| 16-16-16 SBZ | 16MBT16N | 1610-3-16TTM | 1 | 1 | 3.88 | 1.94 | 1.84 | 1.45 | .94 | 1-3/8 |

NOTE: A and C dimensions are typical finger-tight.

Dimensions for reference only, subject to change.

NPT Male Branch Tee

For metric tube

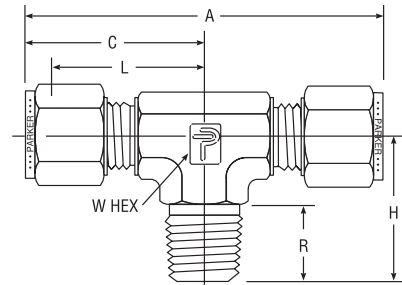
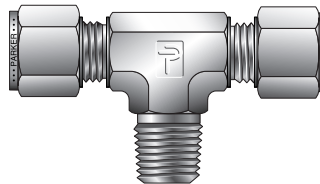

| CPI™ PART NO. | A-LOK® PART NO. | INTER- CHANGES WITH | MILLIMETERS | | | | | | | | INCHES W HEX |
|------------------|--------------------|---------------------------|---------------|---------------|------|------|------|------|------|-------|--------------------|
| | | | TUBE O. D. | NPT THREAD | A | C | H | L | R | | |
| SBZ 6-6-1/8 | M6MBT1/8N | 6MO-3TTM | 6 | 1/8 | 53,9 | 27,0 | 18,8 | 19,6 | 9,7 | 1/2 | |
| SBZ 6-6-1/4 | M6MBT1/4N | 6MO-3-4TTM | 6 | 1/4 | 53,9 | 27,0 | 23,4 | 19,6 | 14,2 | 1/2 | |
| SBZ 8-8-1/8 | M8MBT1/8N | 6MO-3-2TTM | 8 | 1/8 | 59,7 | 29,9 | 20,8 | 22,4 | 9,7 | 5/8 | |
| SBZ 8-8-1/4 | M8MBT1/4N | 8MO-3-4TTM | 8 | 1/4 | 59,7 | 29,9 | 25,4 | 22,4 | 14,2 | 5/8 | |
| SBZ 10-10-1/4 | M10MBT1/4N | 10MO-3-4TTM | 10 | 1/4 | 67,0 | 33,5 | 28,2 | 25,9 | 14,2 | 13/16 | |
| SBZ 10-10-3/8 | M10MBT3/8N | 10MO-3-6TTM | 10 | 3/8 | 67,0 | 33,5 | 28,2 | 25,9 | 14,2 | 13/16 | |
| SBZ 12-12-1/4 | M12MBT1/4N | 12MO-3-4TTM | 12 | 1/4 | 72,0 | 36,0 | 28,2 | 25,9 | 14,2 | 13/16 | |
| SBZ 12-12-3/8 | M12MBT3/8N | 12MO-3-6TTM | 12 | 3/8 | 72,0 | 36,0 | 28,2 | 25,9 | 14,2 | 13/16 | |
| SBZ 12-12-1/2 | M12MBT1/2N | 12MO-3-8TTM | 12 | 1/2 | 72,0 | 36,0 | 33,0 | 25,9 | 19,0 | 13/16 | |
| SBZ 16-16-1/2 | M16MBT1/2N | 16MO-3-8TTM | 16 | 1/2 | 77,6 | 38,8 | 35,8 | 28,7 | 19,1 | 1 | |

NOTE: A and C dimensions are typical finger-tight.

Dimensions for reference only, subject to change.

NPT Female Connector For fractional tube

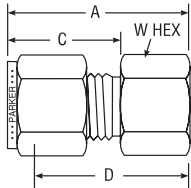
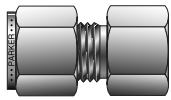

| CPI™ PART NO. | A-LOK® PART NO. | INTER- CHANGES WITH | INCHES | | | | | |
|------------------|--------------------|---------------------------|---------------|--------------------|------|------|------|----------|
| | | | TUBE O. D. | NPT PIPE THREAD | A | C | D | W HEX |
| 1-1 GBZ | 1FSC1N | 100-7-1 | 1/16 | 1/16 | 0.93 | 0.43 | 0.78 | 7/16 |
| 1-2 GBZ | 1FSC2N | 100-7-2 | 1/16 | 1/8 | 0.95 | 0.43 | 0.81 | 9/16 |
| 2-2 GBZ | 2FSC2N | 200-7-2 | 1/8 | 1/8 | 1.14 | 0.60 | 0.88 | 9/16 |
| 2-4 GBZ | 2FSC4N | 200-7-4 | 1/8 | 1/4 | 1.32 | 0.60 | 1.06 | 3/4 |
| 3-2 GBZ | 3FSC2N | 300-7-2 | 3/16 | 1/8 | 1.17 | 0.64 | 0.91 | 9/16 |
| 3-4 GBZ | 3FSC4N | 300-7-4 | 3/16 | 1/4 | 1.35 | 0.64 | 1.09 | 3/4 |
| 4-2 GBZ | 4FSC2N | 400-7-2 | 1/4 | 1/8 | 1.23 | 0.70 | 0.94 | 9/16 |
| 4-4 GBZ | 4FSC4N | 400-7-4 | 1/4 | 1/4 | 1.42 | 0.70 | 1.13 | 3/4 |
| 4-6 GBZ | 4FSC6N | 400-7-6 | 1/4 | 3/8 | 1.48 | 0.70 | 1.19 | 7/8 |
| 4-8 GBZ | 4FSC8N | 400-7-8 | 1/4 | 1/2 | 1.67 | 0.70 | 1.38 | 1-1/16 |
| 5-2 GBZ | 5FSC2N | 500-7-2 | 5/16 | 1/8 | 1.27 | 0.73 | 0.97 | 9/16 |
| 5-4 GBZ | 5FSC4N | 500-7-4 | 5/16 | 1/4 | 1.46 | 0.73 | 1.16 | 3/4 |
| 5-6 GBZ | 5FSC6N | 500-7-6 | 5/16 | 3/8 | 1.51 | 0.73 | 1.22 | 7/8 |
| 6-2 GBZ | 6FSC2N | 600-7-2 | 3/8 | 1/8 | 1.29 | 0.76 | 1.00 | 5/8 |
| 6-4 GBZ | 6FSC4N | 600-7-4 | 3/8 | 1/4 | 1.48 | 0.76 | 1.19 | 3/4 |
| 6-6 GBZ | 6FSC6N | 600-7-6 | 3/8 | 3/8 | 1.54 | 0.76 | 1.25 | 7/8 |
| 6-8 GBZ | 6FSC8N | 600-7-8 | 3/8 | 1/2 | 1.73 | 0.76 | 1.44 | 1-1/16 |
| 6-12 GBZ | 6FSC12N | 600-7-12 | 3/8 | 3/4 | 1.85 | 0.76 | 1.56 | 1-1/4 |
| 8-4 GBZ | 8FSC4N | 810-7-4 | 1/2 | 1/4 | 1.59 | 0.87 | 1.19 | 13/16 |
| 8-6 GBZ | 8FSC6N | 810-7-6 | 1/2 | 3/8 | 1.65 | 0.87 | 1.25 | 7/8 |
| 8-8 GBZ | 8FSC8N | 810-7-8 | 1/2 | 1/2 | 1.84 | 0.87 | 1.44 | 1-1/16 |
| 8-12 GBZ | 8FSC12N | 810-7-12 | 1/2 | 3/4 | 1.96 | 0.87 | 1.56 | 1-1/4 |
| 10-6 GBZ | 10FSC6N | 1010-7-6 | 5/8 | 3/8 | 1.65 | 0.87 | 1.25 | 15/16 |
| 10-8 GBZ | 10FSC8N | 1010-7-8 | 5/8 | 1/2 | 1.84 | 0.87 | 1.44 | 1-1/16 |
| 10-12 GBZ | 10FSC12N | 1010-7-12 | 5/8 | 3/4 | 1.96 | 0.87 | 1.56 | 1-3/8 |
| 12-8 GBZ | 12FSC8N | 1210-7-8 | 3/4 | 1/2 | 1.84 | 0.87 | 1.44 | 1-1/16 |
| 12-12 GBZ | 12FSC12N | 1210-7-12 | 3/4 | 3/4 | 1.96 | 0.87 | 1.56 | 1-3/8 |
| 14-12 GBZ | 14FSC12N | 1410-7-12 | 7/8 | 3/4 | 1.96 | 0.87 | 1.56 | 1-3/8 |
| 16-12 GBZ | 16FSC12N | 1610-7-12 | 1 | 3/4 | 2.15 | 1.05 | 1.66 | 1-3/8 |
| 16-16 GBZ | 16FSC16N | 1610-7-16 | 1 | 1 | 2.46 | 1.05 | 1.97 | 1-5/8 |
| 20-20 GBZ | 20FSC20N | 2010-7-20 | 1-1/4 | 1-1/4 | 2.94 | 1.52 | 2.08 | 2 |
| 24-24 GBZ | 24FSC24N | 2410-7-24 | 1-1/2 | 1-1/2 | 3.28 | 1.77 | 2.22 | 2-3/8 |
| 32-32 GBZ | 32FSC32N | 3210-7-32 | 2 | 2 | 4.00 | 2.47 | 2.53 | 2-7/8 |

NOTE: A and C dimensions are typical finger-tight.

Dimensions for reference only, subject to change.

Sizes 20, 24, 32 require additional lubrication prior to assembly.

NPT Female Connector For metric tube

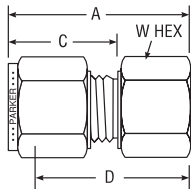
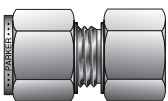

| CPI™ PART NO. | A-LOK® PART NO. | INTER- CHANGES WITH | MILLIMETERS | | | | | |
|------------------|--------------------|---------------------------|---------------|---------------|------|------|------|----------|
| | | | TUBE O. D. | NPT THREAD | A | C | D | W HEX |
| GBZ 3-1/8 | M3FSC1/8N | 3MO-7-2 | 3 | 1/8 | 28,8 | 15,3 | 22,2 | 14,0 |
| GBZ 3-1/4 | M3FSC1/4N | 3MO-7-4 | 3 | 1/4 | 33,6 | 15,3 | 27,0 | 19,0 |
| GBZ 4-1/8 | M4FSC1/8N | 4MO-7-2 | 4 | 1/8 | 29,6 | 16,1 | 23,0 | 14,0 |
| GBZ 6-1/8 | M6FSC1/8N | 6MO-7-2 | 6 | 1/8 | 31,3 | 17,7 | 23,8 | 14,0 |
| GBZ 6-1/4 | M6FSC1/4N | 6MO-7-4 | 6 | 1/4 | 36,1 | 17,7 | 28,6 | 19,0 |
| GBZ 6-3/8 | M6FSC3/8N | 6MO-7-6 | 6 | 3/8 | 37,7 | 17,7 | 30,2 | 22,0 |
| GBZ 6-1/2 | M6FSC1/2N | 6MO-7-8 | 6 | 1/2 | 42,5 | 17,7 | 35,0 | 27,0 |
| GBZ 8-1/8 | M8FSC1/8N | 8MO-7-2 | 8 | 1/8 | 32,1 | 18,6 | 24,6 | 14,0 |
| GBZ 8-1/4 | M8FSC1/4N | 8MO-7-4 | 8 | 1/4 | 36,9 | 18,6 | 29,4 | 19,0 |
| GBZ 8-3/8 | M8FSC3/8N | 8MO-7-6 | 8 | 3/8 | 38,5 | 18,6 | 31,0 | 22,0 |
| GBZ 10-1/4 | M10FSC1/4N | 10MO-7-4 | 10 | 1/4 | 37,8 | 19,5 | 30,2 | 19,0 |
| GBZ 10-3/8 | M10FSC3/8N | 10MO-7-6 | 10 | 3/8 | 39,4 | 19,5 | 31,8 | 22,0 |
| GBZ 10-1/2 | M10FSC1/2N | 10MO-7-8 | 10 | 1/2 | 44,1 | 19,5 | 36,5 | 27,0 |
| GBZ 12-1/4 | M12FSC1/4N | 12MO-7-4 | 12 | 1/4 | 41,9 | 22,0 | 31,8 | 22,0 |
| GBZ 12-3/8 | M12FSC3/8N | 12MO-7-6 | 12 | 3/8 | 41,9 | 22,0 | 31,8 | 22,0 |
| GBZ 12-1/2 | M12FSC1/2N | 12MO-7-8 | 12 | 1/2 | 46,6 | 22,0 | 36,5 | 27,0 |
| GBZ 16-3/8 | M16FSC3/8N | 16MO-7-6 | 16 | 3/8 | 41,9 | 22,0 | 31,8 | 27,0 |
| GBZ 16-1/2 | M16FSC1/2N | 16MO-7-8 | 16 | 1/2 | 46,9 | 22,0 | 36,5 | 27,0 |
| GBZ 20-1/2 | M20FSC1/2N | 20MO-7-8 | 20 | 1/2 | 47,9 | 22,0 | 37,8 | 30,0 |
| GBZ 20-3/4 | M20FSC3/4N | 20MO-7-12 | 20 | 3/4 | 49,7 | 22,0 | 39,6 | 35,0 |
| GBZ 22-3/4 | M22FSC3/4N | 22MO-7-12 | 22 | 3/4 | 49,7 | 22,0 | 39,6 | 35,0 |
| GBC 25-3/4 | M25FSC3/4N | 25MO-7-12 | 25 | 3/4 | 53,6 | 26,5 | 41,3 | 35,0 |
| GBC 25-1 | M25FSC1N | 25MO-7-16 | 25 | 1 | 62,3 | 26,5 | 50,0 | 41,0 |

Dimensions for reference only, subject to change.



BSP Taper Female Connector For fractional tube

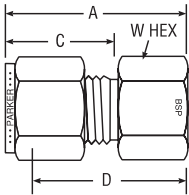
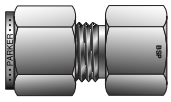

| CPI™ PART NO. | A-LOK® PART NO. | INTER- CHANGES WITH | INCHES | | | | | | |
|------------------|--------------------|---------------------------|---------------|----------------|------|-----|------|----------|------|
| | | | TUBE O. D. | BSPT THREAD | A | C | D | W HEX | BORE |
| 4-2K GBZ | 4FSC2K | 400-7-2RT | 1/4 | 1/8 | 1.24 | .70 | 0.94 | 9/16 | .19 |
| 4-4K GBZ | 4FSC4K | 400-7-4RT | 1/4 | 1/4 | 1.42 | .70 | 1.13 | 3/4 | .19 |
| 4-6K GBZ | 4FSC6K | 400-7-6RT | 1/4 | 3/8 | 1.49 | .70 | 1.19 | 7/8 | .19 |
| 4-8K GBZ | 4FSC8K | 400-7-8RT | 1/4 | 1/2 | 1.68 | .70 | 1.38 | 1-1/16 | .19 |
| 6-4K GBZ | 6FSC4K | 600-7-4RT | 3/8 | 1/4 | 1.48 | .76 | 1.19 | 3/4 | .28 |
| 6-6K GBZ | 6FSC6K | 600-7-6RT | 3/8 | 3/8 | 1.54 | .76 | 1.25 | 7/8 | .28 |
| 6-8K GBZ | 6FSC8K | 600-7-8RT | 3/8 | 1/2 | 1.73 | .76 | 1.44 | 1-1/16 | .28 |
| 8-4K GBZ | 8FSC4K | 810-7-4RT | 1/2 | 1/4 | 1.59 | .87 | 1.19 | 13/16 | .406 |
| 8-6K GBZ | 8FSC6K | 810-7-6RT | 1/2 | 3/8 | 1.65 | .87 | 1.25 | 7/8 | .406 |
| 8-8K GBZ | 8FSC8K | 810-7-8RT | 1/2 | 1/2 | 1.84 | .87 | 1.44 | 1-1/16 | .406 |

Dimensions for reference only, subject to change.

BSP Taper Female Connector For metric tube

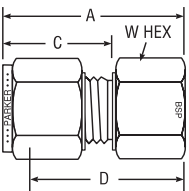
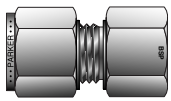

| CPI™ PART NO. | A-LOK® PART NO. | INTER- CHANGES WITH | MILLIMETERS | | | | | |
|------------------|--------------------|---------------------------|---------------|----------------|------|------|------|----------|
| | | | TUBE O. D. | BSPT THREAD | A | C | D | W HEX |
| GBZ 3-1/8K | M3FSC1/8K | 3MO-7-2RT | 3 | 1/8 | 29,2 | 15,3 | 22,6 | 14,0 |
| GBZ 6-1/8K | M6FSC1/8K | 6MO-7-2RT | 6 | 1/8 | 31,3 | 17,7 | 23,8 | 14,0 |
| GBZ 6-1/4K | M6FSC1/4K | 6MO-7-4RT | 6 | 1/4 | 35,8 | 17,7 | 28,3 | 19,0 |
| GBZ 6-3/8K | M6FSC3/8K | 6MO-7-6RT | 6 | 3/8 | 37,6 | 17,7 | 30,1 | 22,0 |
| GBZ 6-1/2K | M6FSC1/2K | 6MO-7-8RT | 6 | 1/2 | 42,5 | 17,7 | 35,0 | 27,0 |
| GBZ 8-1/8K | M8FSC1/8K | 8MO-7-2RT | 8 | 1/8 | 32,8 | 18,6 | 25,3 | 15,0 |
| GBZ 8-1/4K | M8FSC1/4K | 8MO-7-4RT | 8 | 1/4 | 37,0 | 18,6 | 29,5 | 19,0 |
| GBZ 8-3/8K | M8FSC3/8K | 8MO-7-6RT | 8 | 3/8 | 38,5 | 18,6 | 31,0 | 22,0 |
| GBZ 8-1/2K | M8FSC1/2K | 8MO-7-8RT | 8 | 1/2 | 43,3 | 18,6 | 35,8 | 27,0 |
| GBZ 10-1/8K | M10FSC1/8K | 10MO-7-2RT | 10 | 1/8 | 33,0 | 19,5 | 25,4 | 18,0 |
| GBZ 10-1/4K | M10FSC1/4K | 10MO-7-4RT | 10 | 1/4 | 37,8 | 19,5 | 30,2 | 19,0 |
| GBZ 10-3/8K | M10FSC3/8K | 10MO-7-6RT | 10 | 3/8 | 39,4 | 19,5 | 31,8 | 22,0 |
| GBZ 10-1/2K | M10FSC1/2K | 10MO-7-8RT | 10 | 1/2 | 44,2 | 19,5 | 36,6 | 27,0 |
| GBZ 12-1/4K | M12FSC1/4K | 12MO-7-4RT | 12 | 1/4 | 40,3 | 22,0 | 30,2 | 22,0 |
| GBZ 12-3/8K | M12FSC3/8K | 12MO-7-6RT | 12 | 3/8 | 41,9 | 22,0 | 31,8 | 22,0 |
| GBZ 12-1/2K | M12FSC1/2K | 12MO-7-8RT | 12 | 1/2 | 46,7 | 22,0 | 36,6 | 27,0 |
| GBZ 16-1/2K | M16FSC1/2K | 16MO-7-8RT | 16 | 1/2 | 48,4 | 22,0 | 38,3 | 18,0 |
| GBZ 20-1/2K | M20FSC1/2K | 20MO-7-8RT | 20 | 1/2 | 54,7 | 22,0 | 44,6 | 30,0 |
| GBZ 20-3/4K | M20FSC3/4K | 20MO-7-12RT | 20 | 3/4 | 49,7 | 22,0 | 39,6 | 35,0 |
| GBZ 22-1K | M22FSC1K | 22MO-7-16RT | 22 | 1 | 57,9 | 22,0 | 47,8 | 41,0 |
| GBZ 25-3/4K | M25FSC3/4K | 25MO-7-12RT | 25 | 3/4 | 54,3 | 26,5 | 42,1 | 35,0 |
| GBZ 25-1K | M25FSC1K | 25MO-7-16RT | 25 | 1 | 61,5 | 26,5 | 49,3 | 41,0 |

NOTE: A and C dimensions are typical finger-tight.

Dimensions for reference only, subject to change.

Color Coding

For easy reference, table column headings are color indicated as follows:

fractional



metric



NPT Female Bulkhead Connector For fractional tube

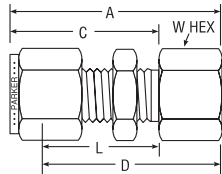
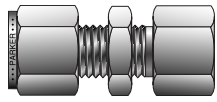

| CPI™ PART NO. | A-LOK® PART NO. | INTER- CHANGES WITH | INCHES | | | | | | |
|------------------|--------------------|---------------------------|--------------|--------------------|------|------|------|------|----------|
| | | | TUBE O.D. | NPT PIPE THREAD | A | C | D | L | W HEX |
| 2-2 GH2BZ | 2FBC2N | 200-71-2 | 1/8 | 1/8 | 1.76 | 1.23 | 1.50 | 0.97 | 9/16 |
| 3-2 GH2BZ | 3FBC2N | 300-71-2 | 3/16 | 1/8 | 1.79 | 1.26 | 1.53 | 1.00 | 9/16 |
| 4-2 GH2BZ | 4FBC2N | 400-71-2 | 1/4 | 1/8 | 1.85 | 1.31 | 1.56 | 1.02 | 5/8 |
| 4-4 GH2BZ | 4FBC4N | 400-71-4 | 1/4 | 1/4 | 2.04 | 1.31 | 1.75 | 1.02 | 3/4 |
| 5-2 GH2BZ | 5FBC2N | 500-71-2 | 5/16 | 1/8 | 1.96 | 1.42 | 1.66 | 1.12 | 11/16 |
| 5-8 GH2BZ | 5FBC8N | 500-71-8 | 5/16 | 1/2 | 2.38 | 1.42 | 2.08 | 1.12 | 1-1/16 |
| 6-4 GH2BZ | 6FBC4N | 600-71-4 | 3/8 | 1/4 | 2.17 | 1.44 | 1.88 | 1.15 | 3/4 |
| 8-6 GH2BZ | 8FBC6N | 810-71-6 | 1/2 | 3/8 | 2.43 | 1.65 | 2.03 | 1.25 | 15/16 |
| 8-8 GH2BZ | 8FBC8N | 810-71-8 | 1/2 | 1/2 | 2.62 | 1.65 | 2.22 | 1.25 | 1-1/16 |
| 10-8 GH2BZ | 10FBC8N | 1010-71-8 | 5/8 | 1/2 | 2.65 | 1.68 | 2.25 | 1.28 | 1-1/16 |
| 12-12 GH2BZ | 12FBC12N | 1210-71-12 | 3/4 | 3/4 | 2.90 | 1.87 | 2.50 | 1.47 | 1-3/8 |
| 14-12 GH2BZ | 14FBC12N | 1410-71-12 | 7/8 | 3/4 | 3.18 | 2.09 | 2.78 | 1.69 | 1-3/8 |
| 16-16 GH2BZ | 16FBC16N | 1610-71-16 | 1 | 1 | 3.68 | 2.27 | 3.19 | 1.78 | 1-5/8 |

NOTE: A and C dimensions are typical finger-tight.

Dimensions for reference only, subject to change.

For bulkhead hole drill size and maximum bulkhead thickness, see page 29, Part BC.

NPT Female Bulkhead Connector For metric tube

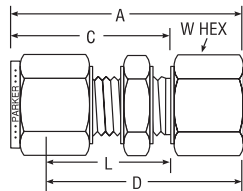
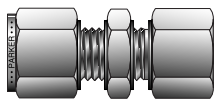

| CPI™ PART NO. | A-LOK® PART NO. | INTER- CHANGES WITH | MILLIMETERS | | | | | | | | |
|------------------|--------------------|---------------------------|--------------|---------------|------|------|------|------|----------|---------------------------------|--------------------------|
| | | | TUBE O.D. | NPT THREAD | A | C | D | L | W HEX | B'HEAD HOLE DRILL SIZE | MAX. B'HEAD THICK. |
| GH2BZ 6-1/8 | M6FBC1/8N | 6MO-71-2 | 6 | 1/8 | 47,2 | 33,7 | 39,7 | 26,2 | 16,0 | 11,5 | 10,2 |
| GH2BZ 6-1/4 | M6FBC1/4N | 6MO-71-4 | 6 | 1/4 | 52,0 | 33,7 | 44,5 | 26,2 | 19,0 | 11,5 | 10,2 |
| GH2BZ 8-1/8 | M8FBC1/8N | 8MO-71-2 | 8 | 1/8 | 49,6 | 36,1 | 42,1 | 28,5 | 18,0 | 13,1 | 11,2 |
| GH2BZ 10-1/4 | M10FBC1/4N | 10MO-71-4 | 10 | 1/4 | 55,2 | 37,0 | 47,6 | 29,4 | 19,0 | 16,3 | 11,2 |
| GH2BZ 12-3/8 | M12FBC3/8N | 12MO-71-6 | 12 | 3/8 | 60,9 | 41,9 | 50,8 | 31,8 | 24,0 | 19,5 | 12,7 |
| GH2BZ 12-1/2 | M12FBC1/2N | 12MO-71-8 | 12 | 1/2 | 66,4 | 41,9 | 56,3 | 31,8 | 27,0 | 19,5 | 12,7 |

NOTE: A and C dimensions are typical finger-tight.

Dimensions for reference only, subject to change.

For bulkhead hole drill size and maximum bulkhead thickness, see page 29, Part BC.

BSPP Gauge Connector For fractional tube

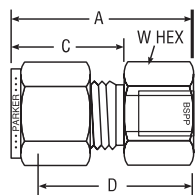
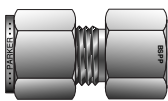

| CPI™ PART NO. | A-LOK® PART NO. | INTER- CHANGES WITH | INCHES | | | | | | |
|------------------|--------------------|---------------------------|--------------|----------------|------|-----|------|----------|------|
| | | | TUBE O.D. | BSPP THREAD | A | C | D | W HEX | BORE |
| 4-4GC GBZ | 4FSC4GC | 400-7-4RG | 1/4 | 1/4 | 1.48 | .70 | 1.19 | 3/4 | .19 |
| 4-6GC GBZ | 4FSC6GC | 400-7-6RG | 1/4 | 3/8 | 1.48 | .70 | 1.19 | 7/8 | .19 |
| 4-8GC GBZ | 4FSC8GC | 400-7-8RG | 1/4 | 1/2 | 1.70 | .70 | 1.41 | 1-1/16 | .19 |
| 5-4GC GBZ | 5FSC4GC | 500-7-4RG | 5/16 | 1/4 | 1.51 | .73 | 1.22 | 3/4 | .21 |
| 5-8GC GBZ | 5FSC8GC | 500-7-8RG | 5/16 | 1/2 | 1.59 | .73 | 1.30 | 1-1/16 | .28 |
| 6-4GC GBZ | 6FSC4GC | 600-7-4RG | 3/8 | 1/4 | 1.55 | .76 | 1.25 | 3/4 | .21 |
| 6-6GC GBZ | 6FSC6GC | 600-7-6RG | 3/8 | 3/8 | 1.55 | .76 | 1.25 | 7/8 | .26 |
| 6-8GC GBZ | 6FSC8GC | 600-7-8RG | 3/8 | 1/2 | 1.63 | .76 | 1.33 | 1-1/16 | .28 |
| 8-4GC GBZ | 8FSC4GC | 810-7-4RG | 1/2 | 1/4 | 1.65 | .86 | 1.25 | 13/16 | .21 |
| 8-6GC GBZ | 8FSC6GC | 810-7-6RG | 1/2 | 3/8 | 1.75 | .86 | 1.35 | 7/8 | .26 |
| 8-8GC GBZ | 8FSC8GC | 810-7-8RG | 1/2 | 1/2 | 1.90 | .86 | 1.50 | 1-1/16 | .28 |

NOTE: A and C dimensions are typical finger-tight.

Dimensions for reference only, subject to change.

See catalog 4260 Pipe/ISO Fittings for detailed information.
Sealing Washer on page 73 to be used with this fitting.

BSPP Gauge Connector

For metric tube

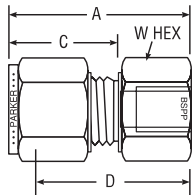
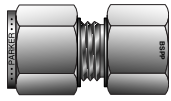

| CPI™ PART NO. | A-LOK® PART NO. | INTER- CHANGES WITH | INCHES | | | | | |
|------------------|--------------------|---------------------------|--------------|----------------|------|------|------|----------|
| | | | TUBE O.D. | BSPP THREAD | A | C | D | W HEX |
| GBZ 3-1/4GC | M3GC1/4R | 3MO-7-4RG | 3 | 1/4 | 35,3 | 15,3 | 28,7 | 19,0 |
| GBZ 6-1/4GC | M6GC1/4R | 6MO-7-4RG | 6 | 1/4 | 37,7 | 17,7 | 30,2 | 19,0 |
| GBZ 6-3/8GC | M6GC3/8R | 6MO-7-6RG | 6 | 3/8 | 37,7 | 17,7 | 30,2 | 22,0 |
| GBZ 6-1/2GC | M6GC1/2R | 6MO-7-8RG | 6 | 1/2 | 43,2 | 17,7 | 35,7 | 27,0 |
| GBZ 8-1/4GC | M8GC1/4R | 8MO-7-4RG | 8 | 1/4 | 38,5 | 18,6 | 31,0 | 19,0 |
| GBZ 8-3/8GC | M8GC3/8R | 8MO-7-6RG | 8 | 3/8 | 40,8 | 18,6 | 33,3 | 22,0 |
| GBZ 8-1/2GC | M8GC1/2R | 8MO-7-8RG | 8 | 1/2 | 44,0 | 18,6 | 36,5 | 27,0 |
| GBZ 10-1/4GC | M10GC1/4R | 10MO-7-4RG | 10 | 1/4 | 39,4 | 19,5 | 31,8 | 19,0 |
| GBZ 10-3/8GC | M10GC3/8R | 10MO-7-6RG | 10 | 3/8 | 38,8 | 19,5 | 31,2 | 22,0 |
| GBC 10-1/2GC | M10GC1/2R | 10MO-7-8RG | 10 | 1/2 | 41,3 | 19,5 | 33,7 | 27,0 |
| GBC 12-1/4GC | M12GC1/4R | 12MO-7-4RG | 12 | 1/4 | 41,9 | 22,0 | 31,8 | 22,0 |
| GBC 12-3/8GC | M12GC3/8R | 12MO-7-6RG | 12 | 3/8 | 44,4 | 22,0 | 34,3 | 22,0 |
| GBC 12-1/2GC | M12GC1/2R | 12MO-7-8RG | 12 | 1/2 | 48,2 | 22,0 | 38,1 | 27,0 |

NOTE: A and C dimensions are typical finger-tight.

Dimensions for reference only, subject to change.

See Catalog 4260 Pipe/ISO Fittings for detailed information.
Sealing Washer on page 73 to be used with this fitting.

NPT Female Elbow

For fractional tube

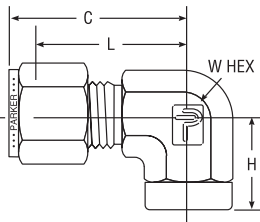
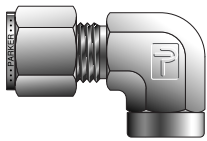

| CPI™ PART NO. | A-LOK® PART NO. | INTER- CHANGES WITH | INCHES | | | | | |
|------------------|--------------------|---------------------------|--------------|--------------------|------|------|------|----------|
| | | | TUBE O.D. | NPT PIPE THREAD | C | H | L | W HEX |
| 1-1 DBZ | 1FEL1N | 100-8-1 | 1/16 | 1/16 | 0.75 | 0.50 | 0.60 | 7/16 |
| 1-2 DBZ | 1FEL2N | 100-8-2 | 1/16 | 1/8 | 0.79 | 0.75 | 0.64 | 9/16 |
| 2-2 DBZ | 2FEL2N | 200-8-2 | 1/8 | 1/8 | 0.97 | 0.75 | 0.71 | 9/16 |
| 2-4 DBZ | 2FEL4N | 200-8-4 | 1/8 | 1/4 | 1.10 | 0.88 | 0.84 | 3/4 |
| 3-2 DBZ | 3FEL2N | 300-8-2 | 3/16 | 1/8 | 1.00 | 0.75 | 0.74 | 9/16 |
| 4-2 DBZ | 4FEL2N | 400-8-2 | 1/4 | 1/8 | 1.06 | 0.75 | 0.77 | 9/16 |
| 4-4 DBZ | 4FEL4N | 400-8-4 | 1/4 | 1/4 | 1.20 | 0.88 | 0.91 | 11/16 |
| 4-6 DBZ | 4FEL6N | 400-8-6 | 1/4 | 3/8 | 1.25 | 0.88 | 0.96 | 13/16 |
| 4-8 DBZ | 4FEL8N | 400-8-8 | 1/4 | 1/2 | 1.36 | 1.13 | 1.07 | 1 |
| 5-2 DBZ | 5FEL2N | 500-8-2 | 5/16 | 1/8 | 1.13 | 0.75 | 0.84 | 9/16 |
| 5-4 DBZ | 5FEL4N | 500-8-4 | 5/16 | 1/4 | 1.24 | 0.88 | 0.94 | 11/16 |
| 6-2 DBZ | 6FEL2N | 600-8-2 | 3/8 | 1/8 | 1.20 | 0.75 | 0.91 | 5/8 |
| 6-4 DBZ | 6FEL4N | 600-8-4 | 3/8 | 1/4 | 1.26 | 0.88 | 0.97 | 11/16 |
| 6-6 DBZ | 6FEL6N | 600-8-6 | 3/8 | 3/8 | 1.31 | 0.88 | 1.02 | 13/16 |
| 6-8 DBZ | 6FEL8N | 600-8-8 | 3/8 | 1/2 | 1.42 | 1.13 | 1.13 | 1 |
| 8-4 DBZ | 8FEL4N | 810-8-4 | 1/2 | 1/4 | 1.42 | 0.88 | 1.02 | 13/16 |
| 8-6 DBZ | 8FEL6N | 810-8-6 | 1/2 | 3/8 | 1.42 | 0.88 | 1.02 | 13/16 |
| 8-8 DBZ | 8FEL8N | 810-8-8 | 1/2 | 1/2 | 1.53 | 1.13 | 1.13 | 1 |
| 10-6 DBZ | 10FEL6N | 1010-8-6 | 5/8 | 3/8 | 1.50 | 0.88 | 1.10 | 15/16 |
| 10-8 DBZ | 10FEL8N | 1010-8-8 | 5/8 | 1/2 | 1.57 | 1.13 | 1.17 | 1-1/16 |
| 12-8 DBZ | 12FEL8N | 1210-8-8 | 3/4 | 1/2 | 1.57 | 1.13 | 1.17 | 1-1/16 |
| 12-12 DBZ | 12FEL12N | 1210-8-12 | 3/4 | 3/4 | 1.76 | 1.25 | 1.36 | 1-3/8 |
| 14-12 DBZ | 14FEL12N | 1410-8-12 | 7/8 | 3/4 | 1.76 | 1.25 | 1.36 | 1-3/8 |
| 16-12 DBZ | 16FEL12N | 1610-8-12 | 1 | 3/4 | 1.93 | 1.25 | 1.45 | 1-3/8 |
| 16-16 DBZ | 16FEL16N | 1610-8-16 | 1 | 1 | 2.02 | 1.50 | 1.53 | 1-5/8 |

NOTE: C dimension is typical finger-tight.

Dimensions for reference only, subject to change.

NPT Female Elbow

For metric tube

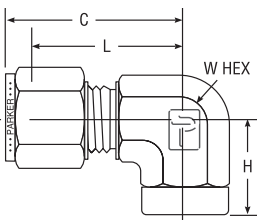

| CPI™ PART NO. | A-LOK® PART NO. | INTER- CHANGES WITH | MILLIMETERS | | | | INCHES | |
|------------------|--------------------|---------------------------|--------------|---------------|------|------|--------|----------|
| | | | TUBE O.D. | NPT THREAD | C | H | L | W HEX |
| DBZ 6-1/8 | M6FEL1/8N | 6MO-8-2 | 6 | 1/8 | 27,0 | 19,0 | 19,6 | 1/2 |
| DBZ 6-1/4 | M6FEL1/4N | 6MO-8-4 | 6 | 1/4 | 29,8 | 22,4 | 22,4 | 11/16 |
| DBZ 8-1/8 | M8FEL1/8N | 8MO-8-2 | 8 | 1/8 | 28,8 | 19,1 | 21,3 | 9/16 |
| DBZ 8-1/4 | M8FEL1/4N | 8MO-8-4 | 8 | 1/4 | 30,6 | 22,4 | 23,1 | 11/16 |
| DBZ 10-1/4 | M10FEL1/4N | 10MO-8-4 | 10 | 1/4 | 33,5 | 22,4 | 25,9 | 13/16 |
| DBZ 10-3/8 | M10FEL3/8N | 10MO-8-6 | 10 | 3/8 | 33,5 | 22,4 | 25,9 | 13/16 |
| DBZ 10-1/2 | M10FEL1/2N | 10MO-8-8 | 10 | 1/2 | 36,3 | 28,5 | 28,7 | 1 |
| DBZ 12-1/4 | M12FEL1/4N | 12MO-8-4 | 12 | 1/4 | 36,0 | 22,4 | 25,9 | 13/16 |
| DBZ 12-3/8 | M12FEL3/8N | 12MO-8-6 | 12 | 3/8 | 36,0 | 22,4 | 25,9 | 13/16 |
| DBZ 12-1/2 | M12FEL1/2N | 12MO-8-8 | 12 | 1/2 | 38,8 | 28,4 | 28,7 | 1 |
| DBZ 16-3/8 | M16FEL3/8N | 16MO-8-6 | 16 | 3/8 | 39,5 | 23,6 | 29,7 | 1-1/16 |
| DBZ 16-1/2 | M16FEL1/2N | 16MO-8-8 | 16 | 1/2 | 39,5 | 28,4 | 29,7 | 1-1/16 |

NOTE: C dimension is typical finger-tight.

Dimensions for reference only, subject to change.



NPT Female Run Tee

For fractional tube

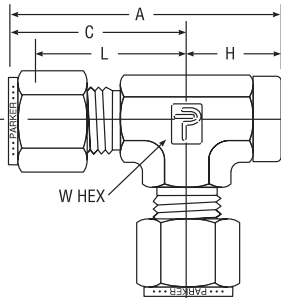
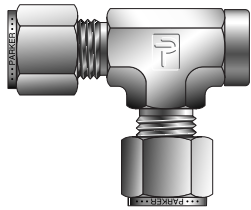

| CPI™ PART NO. | A-LOK® PART NO. | INTER- CHANGES WITH | INCHES | | | | | | |
|------------------|--------------------|---------------------------|--------------|--------------------|------|------|------|------|----------|
| | | | TUBE O.D. | NPT PIPE THREAD | A | C | H | L | W HEX |
| 2-2-2 MBZ | 2FRT2N | 200-3-2TFT | 1/8 | 1/8 | 1.72 | 0.96 | 0.75 | 0.70 | 1/2 |
| 3-2-3 MBZ | 3FRT2N | 300-3-2TFT | 3/16 | 1/8 | 1.76 | 1.01 | 0.75 | 0.74 | 1/2 |
| 4-2-4 MBZ | 4FRT2N | 400-3-2TFT | 1/4 | 1/8 | 1.81 | 1.06 | 0.75 | 0.77 | 1/2 |
| 4-4-4 MBZ | 4FRT4N | 400-3-4TFT | 1/4 | 1/4 | 2.05 | 1.17 | 0.88 | 0.88 | 11/16 |
| 5-2-5 MBZ | 5FRT2N | 500-3-2TFT | 5/16 | 1/8 | 1.92 | 1.17 | 0.75 | 0.88 | 5/8 |
| 6-4-6 MBZ | 6FRT4N | 600-3-4TFT | 3/8 | 1/4 | 2.11 | 1.23 | 0.88 | 0.94 | 11/16 |
| 8-4-8 MBZ | 8FRT4N | 810-3-4TFT | 1/2 | 1/4 | 2.56 | 1.42 | 0.88 | 1.02 | 13/16 |
| 8-6-8 MBZ | 8FRT6N | 810-3-6TFT | 1/2 | 3/8 | 2.30 | 1.42 | 0.88 | 1.02 | 7/8 |
| 8-8-8 MBZ | 8FRT8N | 810-3-8TFT | 1/2 | 1/2 | 2.66 | 1.53 | 1.13 | 1.13 | 1 |
| 10-8-10 MBZ | 10FRT8N | 1010-3-8TFT | 5/8 | 1/2 | 2.70 | 1.57 | 1.13 | 1.17 | 1-1/16 |
| 12-12-12 MBZ | 12FRT12N | 1210-3-12TFT | 3/4 | 3/4 | 3.01 | 1.76 | 1.25 | 1.36 | 1-3/8 |
| 14-8-14 MBZ | 14FRT8N | 1410-3-8TFT | 7/8 | 1/2 | 3.01 | 1.76 | 1.25 | 1.36 | 1-3/8 |
| 14-12-14 MBZ | 14FRT12N | 1410-3-12TFT | 7/8 | 3/4 | 3.01 | 1.76 | 1.25 | 1.36 | 1-3/8 |
| 16-12-16 MBZ | 16FRT12N | 1610-3-12TFT | 1 | 3/4 | 3.18 | 1.93 | 1.25 | 1.45 | 1-3/8 |
| 16-16-16 MBZ | 16FRT16N | 1610-3-16TFT | 1 | 1 | 3.52 | 2.02 | 1.50 | 1.65 | 1-5/8 |

NOTE: A and C dimensions are typical finger-tight.

Dimensions for reference only, subject to change.

NPT Female Run Tee

For metric tube

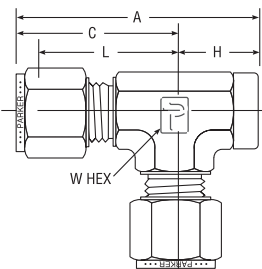
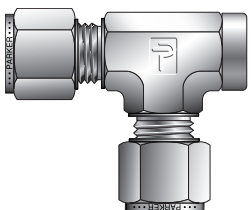

| CPI™ PART NO. | A-LOK® PART NO. | INTER- CHANGES WITH | MILLIMETERS | | | | | | INCHES |
|------------------|--------------------|---------------------------|--------------|---------------|------|------|------|------|----------|
| | | | TUBE O.D. | NPT THREAD | A | C | H | L | W HEX |
| MBZ 6-1/8-6 | M6FRT1/8N | 6MO-3TFT | 6 | 1/8 | 46,0 | 27,0 | 19,0 | 19,6 | 1/2 |
| MBZ 6-1/4-6 | M6FRT1/4N | 6MO-3-4TFT | 6 | 1/4 | 52,1 | 29,8 | 22,4 | 22,4 | 11/16 |
| MBZ 6-1/8-6 | M8FRT1/8N | 8MO-3TFT | 8 | 1/8 | 48,9 | 29,9 | 19,0 | 22,4 | 5/8 |
| MBZ 10-1/4-10 | M10FRT1/4N | 10MO-3TFT | 10 | 1/4 | 55,9 | 33,5 | 22,4 | 25,9 | 13/16 |
| MBZ 12-1/4-12 | M12FRT1/4N | 12MO-3-4TFT | 12 | 1/4 | 58,4 | 36,0 | 22,4 | 25,9 | 13/16 |
| MBZ 12-3/8-12 | M12FRT3/8N | 12MO-3TFT | 12 | 3/8 | 58,4 | 36,0 | 22,4 | 25,9 | 13/16 |
| MBZ 12-1/2-12 | M12FRT1/2N | 12MO-3-8TFT | 12 | 1/2 | 67,3 | 38,8 | 28,5 | 28,7 | 1 |
| MBZ 16-1/2-16 | M16FRT1/2N | 16MO-3TTF | 16 | 1/2 | 68,2 | 39,8 | 28,4 | 29,7 | 1-1/16 |

NOTE: A and C dimensions are typical finger-tight.

Dimensions for reference only, subject to change.

Color Coding

For easy reference, table column headings are color indicated as follows:

fractional

metric



NPT Female Branch Tee For fractional tube

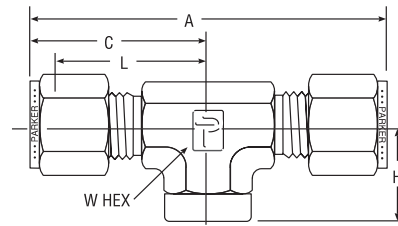
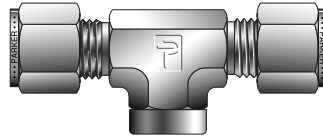

| CPI™ PART NO. | A-LOK® PART NO. | INTER- CHANGES WITH | INCHES | | | | | | |
|------------------|--------------------|---------------------------|--------------|--------------------|------|------|------|------|----------|
| | | | TUBE O.D. | NPT PIPE THREAD | A | C | H | L | W HEX |
| 2-2-2 OBZ | 2FBT2N | 200-3-2TTF | 1/8 | 1/8 | 1.91 | 1.01 | .075 | 0.70 | 1/2 |
| 3-3-2 OBZ | 3FBT2N | 300-3-2TTF | 3/16 | 1/8 | 2.02 | 1.01 | 0.75 | 0.74 | 1/2 |
| 4-4-2 OBZ | 4FBT2N | 400-3-2TTF | 1/4 | 1/8 | 2.12 | 1.06 | 0.75 | 0.77 | 1/2 |
| 4-4-4 OBZ | 4FBT4N | 400-3-4TTF | 1/4 | 1/4 | 2.34 | 1.17 | 0.88 | 0.88 | 11/16 |
| 5-5-2 OBZ | 5FBT2N | 500-3-2TTF | 5/16 | 1/8 | 2.34 | 1.17 | 0.75 | 0.88 | 5/8 |
| 6-6-4 OBZ | 6FBT4N | 600-3-4TTF | 3/8 | 1/4 | 2.46 | 1.23 | 0.88 | 0.94 | 11/16 |
| 8-8-4 OBZ | 8FBT4N | 810-3-4TTF | 1/2 | 1/4 | 2.84 | 1.42 | 0.88 | 1.02 | 13/16 |
| 8-8-6 OBZ | 8FBT6N | 810-3-6TTF | 1/2 | 3/8 | 2.84 | 1.42 | 0.88 | 1.02 | 7/8 |
| 8-8-8 OBZ | 8FBT8N | 810-3-8TTF | 1/2 | 1/2 | 3.06 | 1.53 | 1.13 | 1.13 | 1 |
| 10-10-8 OBZ | 10FBT8N | 1010-3-8TTF | 5/8 | 1/2 | 3.06 | 1.53 | 1.13 | 1.13 | 1 |
| 12-12-12 OBZ | 12FBT12N | 1210-3-12TTF | 3/4 | 3/4 | 3.52 | 1.76 | 1.25 | 1.36 | 1-3/8 |
| 14-14-12 OBZ | 14FBT12N | 1410-3-12TTF | 7/8 | 3/4 | 3.52 | 1.76 | 1.25 | 1.36 | 1-3/8 |
| 16-16-12 OBZ | 16FBT12N | 1610-3-12TTF | 1 | 3/4 | 3.86 | 1.94 | 1.25 | 1.45 | 1-3/8 |
| 16-16-16 OBZ | 16FBT16N | 1610-3-16TTF | 1 | 1 | 4.28 | 2.14 | 1.50 | 1.65 | 1-5/8 |

NOTE: A and C dimensions are typical finger-tight.

Dimensions for reference only, subject to change.

NPT Female Branch Tee For metric tube

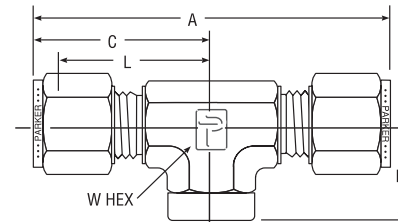
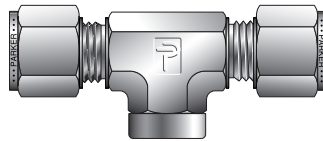

| CPI™ PART NO. | A-LOK® PART NO. | INTER- CHANGES WITH | MILLIMETERS | | | | | | INCHES |
|------------------|--------------------|---------------------------|--------------|---------------|------|------|------|------|----------|
| | | | TUBE O.D. | NPT THREAD | A | C | H | L | W HEX |
| OBZ 6-6-1/8 | M6FBT1/8N | 6MO-3TTF | 6 | 1/8 | 53,9 | 27,0 | 19,0 | 19,6 | 1/2 |
| OBZ 6-6-1/4 | M6FBT1/4N | 6MO-3-4TTF | 6 | 1/4 | 59,5 | 29,8 | 22,4 | 22,4 | 11/16 |
| OBZ 8-8-1/8 | M8FBT1/8N | 8MO-3TTF | 8 | 1/8 | 59,7 | 29,9 | 19,0 | 22,4 | 5/8 |
| OBZ 10-10-1/4 | M10FBT1/4N | 10MO-3TTF | 10 | 1/4 | 67,0 | 33,5 | 22,4 | 25,9 | 13/16 |
| OBZ 12-12-1/8 | M12FBT1/8N | 12MO-3TTF | 12 | 1/8 | 72,0 | 36,0 | 22,3 | 25,9 | 13/16 |
| OBZ 12-12-1/4 | M12FBT1/4N | 12MO-3-4TTF | 12 | 1/4 | 72,0 | 36,0 | 22,3 | 25,9 | 13/16 |
| OBZ 12-12-3/8 | M12FBT3/8N | 12MO-3TTF | 12 | 3/8 | 72,0 | 36,0 | 22,4 | 25,9 | 13/16 |
| OBZ 12-12-1/2 | M12FBT1/2N | 12MO-3-8TTF | 12 | 1/2 | 77,6 | 38,8 | 28,5 | 28,7 | 1 |
| OBZ 16-16-1/2 | M16FBT1/2N | 16MO-3TTF | 16 | 1/2 | 77,6 | 38,8 | 28,4 | 28,7 | 1 |

NOTE: A and C dimensions are typical finger-tight.

Dimensions for reference only, subject to change.

Union For fractional tube

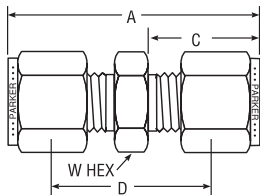
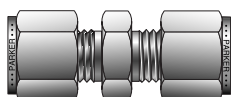

| CPI™ PART NO. | A-LOK® PART NO. | INTER- CHANGES WITH | INCHES | | | | |
|------------------|--------------------|---------------------------|--------------|------|------|------|----------|
| | | | TUBE O.D. | A | C | D | W HEX |
| 1-1 HBZ | 1SC1 | 100-6 | 1/16 | 0.99 | 0.43 | 0.69 | 5/16 |
| 2-2 HBZ | 2SC2 | 200-6 | 1/8 | 1.39 | 0.60 | 0.88 | 7/16 |
| 3-3 HBZ | 3SC3 | 300-6 | 3/16 | 1.48 | 0.64 | 0.95 | 7/16 |
| 4-4 HBZ | 4SC4 | 400-6 | 1/4 | 1.62 | 0.70 | 1.03 | 1/2 |
| 5-5 HBZ | 5SC5 | 500-6 | 5/16 | 1.70 | 0.73 | 1.11 | 9/16 |
| 6-6 HBZ | 6SC6 | 600-6 | 3/8 | 1.77 | 0.76 | 1.19 | 5/8 |
| 8-8 HBZ | 8SC8 | 810-6 | 1/2 | 2.02 | 0.87 | 1.22 | 13/16 |
| 10-10 HBZ | 10SC10 | 1010-6 | 5/8 | 2.05 | 0.87 | 1.25 | 15/16 |
| 12-12 HBZ | 12SC12 | 1210-6 | 3/4 | 2.11 | 0.87 | 1.31 | 1-1/16 |
| 14-14 HBZ | 14SC14 | 1410-6 | 7/8 | 2.18 | 0.87 | 1.38 | 1-3/16 |
| 16-16 HBZ | 16SC16 | 1610-6 | 1 | 2.57 | 1.05 | 1.59 | 1-3/8 |
| 20-20 HBZ | 20SC20 | 2010-6 | 1-1/4 | 3.61 | 1.52 | 1.89 | 1-3/4 |
| 24-24 HBZ | 24SC24 | 2410-6 | 1-1/2 | 4.23 | 1.77 | 2.11 | 2-1/8 |
| 32-32 HBZ | 32SC32 | 3210-6 | 2 | 5.88 | 2.47 | 2.94 | 2-3/4 |

NOTE: A and C dimensions are typical finger-tight.

Dimensions for reference only, subject to change.

Union For metric tube

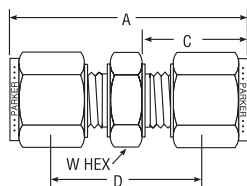
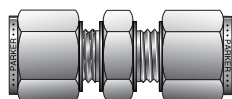

| CPI™ PART NO. | A-LOK® PART NO. | INTER- CHANGES WITH | MILLIMETERS | | | | |
|------------------|--------------------|---------------------------|--------------|------|------|------|----------|
| | | | TUBE O.D. | A | C | D | W HEX |
| HBZ 2-2 | SCM2 | 2MO-6 | 2 | 35,6 | 15,3 | 22,4 | 12,0 |
| HBZ 3-3 | SCM3 | 3MO-6 | 3 | 35,3 | 15,3 | 22,1 | 12,0 |
| HBZ 4-4 | SCM4 | 4MO-4 | 4 | 37,4 | 16,1 | 24,2 | 12,0 |
| HBZ 6-6 | SCM6 | 6MO-6 | 6 | 41,2 | 17,7 | 26,2 | 14,0 |
| HBZ 8-8 | SCM8 | 8MO-6 | 8 | 43,2 | 18,6 | 28,2 | 15,0 |
| HBZ 10-10 | SCM10 | 10MO-6 | 10 | 46,2 | 19,5 | 31,0 | 18,0 |
| HBZ 12-12 | SCM12 | 12MO-6 | 12 | 51,2 | 22,0 | 31,0 | 22,0 |
| HBZ 14-14 | SCM14 | 14MO-6 | 14 | 52,0 | 22,0 | 31,8 | 24,0 |
| HBZ 15-15 | SCM15 | 15MO-6 | 15 | 52,0 | 22,0 | 31,8 | 24,0 |
| HBZ 16-16 | SCM16 | 16MO-6 | 16 | 52,0 | 22,0 | 31,8 | 24,0 |
| HBZ 18-18 | SCM18 | 18MO-6 | 18 | 53,5 | 22,0 | 33,3 | 27,0 |
| HBZ 20-20 | SCM20 | 20MO-6 | 20 | 55,0 | 22,0 | 34,8 | 30,0 |
| HBZ 22-22 | SCM22 | 22MO-6 | 22 | 55,0 | 22,0 | 34,8 | 30,0 |
| HBZ 25-25 | SCM25 | 25MO-6 | 25 | 65,1 | 26,5 | 40,5 | 35,0 |

NOTE: A and C dimensions are typical finger-tight.

Dimensions for reference only, subject to change.

Color Coding

For easy reference, table column headings are color indicated as follows:

fractional



metric



Conversion Union

For metric tube

Metric Tube to Inch Tube

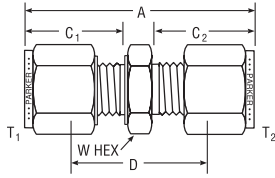
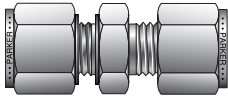

| CPI™ PART NO. | A-LOK® PART NO. | INTER- CHANGES WITH | TUBE O. D. | | MILLIMETERS | | | | |
|------------------|--------------------|---------------------------|----------------------|------------------------|-------------|----------------|----------------|------|----------|
| | | | T ₁ MM | T ₂ INCH | A | C ₁ | C ₂ | D | W HEX |
| HBZ 3-1/8 | M3CU2 | 3MO-6-2 | 3 | 1/8 | 36,3 | 15,3 | 15,3 | 22,6 | 12,0 |
| HBZ 4-1/8 | M4CU2 | 4MO-6-2 | 4 | 1/8 | 36,5 | 16,1 | 15,3 | 23,6 | 12,0 |
| HBZ 4-1/4 | M4CU4 | 4MO-6-4 | 4 | 1/4 | 39,3 | 16,1 | 17,7 | 26,4 | 14,0 |
| HBZ 6-1/8 | M6CU2 | 6MO-6-2 | 6 | 1/8 | 38,5 | 17,7 | 15,3 | 24,6 | 14,0 |
| HBZ 6-1/4 | M6CU4 | 6MO-6-4 | 6 | 1/4 | 41,1 | 17,7 | 17,7 | 25,9 | 14,0 |
| HBZ 6-5/16 | M6CU5 | 6MO-6-5 | 6 | 5/16 | 42,3 | 17,7 | 18,8 | 27,2 | 14,0 |
| HBZ 8-1/4 | M8CU4 | 8MO-6-4 | 8 | 1/4 | 42,3 | 18,6 | 17,7 | 27,2 | 15,0 |
| HBZ 8-3/8 | M8CU6 | 8MO-6-6 | 8 | 3/8 | 44,0 | 18,6 | 19,3 | 29,1 | 15,0 |
| HBZ 10-1/8 | M10CU2 | 10MO-6-2 | 10 | 1/8 | 41,8 | 19,5 | 15,3 | 27,9 | 18,0 |
| HBZ 10-1/4 | M10CU4 | 10MO-6-4 | 10 | 1/4 | 44,5 | 19,5 | 17,7 | 29,2 | 18,0 |
| HBZ 10-3/8 | M10CU6 | 10MO-6-6 | 10 | 3/8 | 46,0 | 19,5 | 19,3 | 30,7 | 18,0 |
| HBZ 12-3/8 | M12CU6 | 12MO-6-6 | 12 | 3/8 | 48,4 | 22,0 | 19,3 | 30,7 | 22,0 |
| HBZ 12-1/2 | M12CU8 | 12MO-6-8 | 12 | 1/2 | 51,1 | 22,0 | 21,8 | 31,0 | 22,0 |
| HBZ 15-1/2 | M15CU8 | 15MO-6-8 | 15 | 1/2 | 52,0 | 22,0 | 21,8 | 32,0 | 24,0 |
| HBZ 16-3/8 | M16CU6 | 16MO-6-6 | 16 | 3/8 | 52,0 | 22,0 | 19,3 | 34,3 | 24,0 |
| HBZ 18-3/4 | M18CU12 | 18MO-6-12 | 18 | 3/4 | 53,5 | 22,0 | 21,8 | 33,5 | 27,0 |

NOTE: A, C₁ and C₂ dimensions are typical finger-tight.

Dimensions for reference only, subject to change.

Reducing Union

For fractional tube

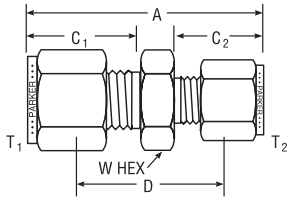
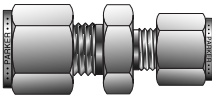

| CPI™ PART NO. | A-LOK® PART NO. | INTER- CHANGES WITH | INCHES | | | | | | |
|------------------|--------------------|---------------------------|------------------------------|------------------------------|------|----------------|----------------|------|----------|
| | | | T ₁ TUBE O. D. | T ₂ TUBE O. D. | A | C ₁ | C ₂ | D | W HEX |
| 2-1 HBZ | 2RU1 | 200-6-1 | 1/8 | 1/16 | 1.21 | 0.60 | .43 | 0.81 | 7/16 |
| 3-1 HBZ | 3RU1 | 300-6-1 | 3/16 | 1/16 | 1.27 | 0.64 | .43 | 0.86 | 7/16 |
| 3-2 HBZ | 3RU2 | 300-6-2 | 3/16 | 1/8 | 1.44 | 0.64 | .60 | 0.92 | 7/16 |
| 4-1 HBZ | 4RU1 | 400-6-1 | 1/4 | 1/16 | 1.38 | 0.70 | .43 | 0.91 | 1/2 |
| 4-2 HBZ | 4RU2 | 400-6-2 | 1/4 | 1/8 | 1.52 | 0.70 | .60 | 0.97 | 1/2 |
| 4-3 HBZ | 4RU3 | 400-6-3 | 1/4 | 3/16 | 1.55 | 0.70 | .64 | 1.00 | 1/2 |
| 5-2 HBZ | 5RU2 | 500-6-2 | 5/16 | 1/8 | 1.58 | 0.73 | .60 | 1.03 | 9/16 |
| 5-4 HBZ | 5RU4 | 500-6-4 | 5/16 | 1/4 | 1.67 | 0.73 | .70 | 1.08 | 9/16 |
| 6-1 HBZ | 6RU1 | 600-6-1 | 3/8 | 1/16 | 1.44 | 0.76 | .43 | 1.00 | 5/8 |
| 6-2 HBZ | 6RU2 | 600-6-2 | 3/8 | 1/8 | 1.61 | 0.76 | .60 | 1.06 | 5/8 |
| 6-4 HBZ | 6RU4 | 600-6-4 | 3/8 | 1/4 | 1.71 | 0.76 | .70 | 1.13 | 5/8 |
| 6-5 HBZ | 6RU5 | 600-6-5 | 3/8 | 5/16 | 1.75 | 0.76 | .73 | 1.16 | 5/8 |
| 8-2 HBZ | 8RU2 | 810-6-2 | 1/2 | 1/8 | 1.75 | 0.87 | .60 | 1.09 | 13/16 |
| 8-4 HBZ | 8RU4 | 810-6-4 | 1/2 | 1/4 | 1.85 | 0.87 | .70 | 1.16 | 13/16 |
| 8-6 HBZ | 8RU6 | 810-6-6 | 1/2 | 3/8 | 1.91 | 0.87 | .76 | 1.22 | 13/16 |
| 10-6 HBZ | 10RU6 | 1010-6-6 | 5/8 | 3/8 | 1.94 | 0.87 | .76 | 1.25 | 15/16 |
| 10-8 HBZ | 10RU8 | 1010-6-8 | 5/8 | 1/2 | 2.05 | 0.87 | .87 | 1.25 | 15/16 |
| 12-4 HBZ | 12RU4 | 1210-6-4 | 3/4 | 1/4 | 1.95 | 0.87 | .76 | 1.25 | 1-1/16 |
| 12-6 HBZ | 12RU6 | 1210-6-6 | 3/4 | 3/8 | 2.00 | 0.87 | .76 | 1.31 | 1-1/16 |
| 12-8 HBZ | 12RU8 | 1210-6-8 | 3/4 | 1/2 | 2.11 | 0.87 | .87 | 1.31 | 1-1/16 |
| 12-10 HBZ | 12RU10 | 1210-6-10 | 3/4 | 5/8 | 2.11 | 0.87 | .87 | 1.31 | 1-1/16 |
| 16-8 HBZ | 16RU8 | 1610-6-8 | 1 | 1/2 | 2.39 | 1.05 | .87 | 1.50 | 1-3/8 |
| 16-12 HBZ | 16RU12 | 1610-6-12 | 1 | 3/4 | 2.39 | 1.05 | .87 | 1.50 | 1-3/8 |

NOTE: A, C₁ and C₂ dimensions are typical finger-tight.

Dimensions for reference only, subject to change.

Reducing Union

For metric tube

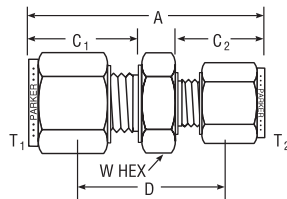
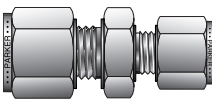

| CPI™ PART NO. | A-LOK® PART NO. | INTER- CHANGES WITH | MILLIMETERS | | | | | | |
|------------------|--------------------|---------------------------|------------------------------|------------------------------|------|----------------|----------------|------|----------|
| | | | T ₁ TUBE O. D. | T ₂ TUBE O. D. | A | C ₁ | C ₂ | D | W HEX |
| HBZ 3-2 | M3RUM2 | 3MO-6-2M | 3 | 2 | 35,8 | 15,3 | 15,3 | 22,6 | 12,0 |
| HBZ 6-2 | M6RUM2 | 6MO-6-2M | 6 | 2 | 38,7 | 17,7 | 15,3 | 24,6 | 14,0 |
| HBZ 6-3 | M6RUM3 | 6MO-6-3M | 6 | 3 | 38,7 | 17,7 | 15,3 | 24,6 | 14,0 |
| HBZ 6-4 | M6RUM4 | 6MO-6-4M | 6 | 4 | 39,5 | 17,7 | 16,1 | 25,4 | 14,0 |
| HBZ 8-6 | M8RUM6 | 8MO-6-6M | 8 | 6 | 42,4 | 18,6 | 17,7 | 27,4 | 15,0 |
| HBZ 10-6 | M10RUM6 | 10MO-6-6M | 10 | 6 | 44,5 | 19,5 | 17,7 | 29,4 | 18,0 |
| HBZ 10-8 | M10RUM8 | 10MO-6-8M | 10 | 8 | 44,5 | 19,5 | 18,6 | 29,4 | 18,0 |
| HBZ 12-6 | M12RUM6 | 12MO-6-6M | 12 | 6 | 47,0 | 22,0 | 17,7 | 29,4 | 22,0 |
| HBZ 12-8 | M12RUM8 | 12MO-6-8M | 12 | 8 | 47,8 | 22,0 | 18,6 | 30,2 | 22,0 |
| HBZ 12-10 | M12RUM10 | 12MO-6-10M | 12 | 10 | 48,7 | 22,0 | 19,5 | 31,0 | 22,0 |
| HBZ 16-10 | M16RUM10 | 16MO-6-10M | 16 | 10 | 49,5 | 22,0 | 19,5 | 31,8 | 24,0 |
| HBZ 16-12 | M16RUM12 | 16MO-6-12M | 16 | 12 | 52,0 | 22,0 | 22,0 | 31,8 | 24,0 |
| HBZ 18-12 | M18RUM12 | 18MO-6-12M | 18 | 12 | 53,5 | 22,0 | 22,0 | 33,3 | 27,0 |
| HBZ 25-18 | M25RUM18 | 25MO-6-18M | 25 | 18 | 60,5 | 26,5 | 22,0 | 38,1 | 35,0 |
| HBZ 25-20 | M25RUM20 | 25MO-6-20M | 25 | 20 | 62,3 | 26,5 | 22,0 | 39,9 | 35,0 |

NOTE: A, C₁ and C₂ dimensions are typical finger-tight.

Dimensions for reference only, subject to change.



Bulkhead Union For fractional tube

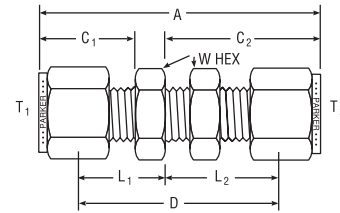
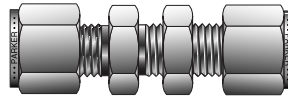

| CPI™ PART NO. | A-LOK® PART NO. | INTER- CHANGES WITH | INCHES | | | | | | | | | |
|------------------|--------------------|---------------------------|--------------|------|----------------|----------------|------|----------------|----------------|----------|--------------------------------|----------------------------------|
| | | | TUBE O.D. | A | C ₁ | C ₂ | D | L ₁ | L ₂ | W HEX | BULKHEAD HOLE DRILL SIZE | MAXIMUM BULKHEAD THICKNESS |
| 1-1 WBZ | 1BC1 | 100-61 | 1/16 | 1.23 | .43 | 0.68 | 0.94 | .28 | 0.53 | 5/16 | 13/64 | 1/8 |
| 2-2 WBZ | 2BC2 | 200-61 | 1/8 | 2.02 | .60 | 1.23 | 1.50 | .34 | 0.97 | 1/2 | 21/64 | 1/2 |
| 2-4 WBZ | 2BC4 | 400-61-2 | 1/8 - 1/4 | 2.17 | .60 | 1.62 | 1.31 | .34 | 1.02 | 5/8 | 29/64 | 17/32 |
| 3-3 WBZ | 3BC3 | 300-61 | 3/16 | 2.11 | .64 | 1.26 | 1.59 | .38 | 1.00 | 9/16 | 25/64 | 1/2 |
| 4-2 WBZ | 4BC2 | 200-61-4 | 1/4 - 1/8 | 2.18 | .70 | 1.23 | 1.62 | .41 | 0.97 | 1/2 | 21/64 | 1/2 |
| 4-4 WBZ | 4BC4 | 400-61 | 1/4 | 2.27 | .70 | 1.31 | 1.69 | .41 | 1.02 | 5/8 | 29/64 | 17/32 |
| 5-5 WBZ | 5BC5 | 500-61 | 5/16 | 2.40 | .73 | 1.42 | 1.81 | .44 | 1.12 | 11/16 | 33/64 | 9/16 |
| 6-6 WBZ | 6BC6 | 600-61 | 3/8 | 2.46 | .76 | 1.44 | 1.88 | .47 | 1.16 | 3/4 | 37/64 | 9/16 |
| 8-8 WBZ | 8BC8 | 810-61 | 1/2 | 2.80 | .87 | 1.65 | 2.00 | .47 | 1.25 | 15/16 | 49/64 | 19/32 |
| 10-10 WBZ | 10BC10 | 1010-61 | 5/8 | 2.86 | .87 | 1.68 | 2.06 | .47 | 1.28 | 1-1/16 | 57/64 | 19/32 |
| 12-12 WBZ | 12BC12 | 1210-61 | 3/4 | 3.11 | .87 | 1.87 | 2.31 | .47 | 1.47 | 1-3/16 | 1-1/64 | 25/32 |
| 14-14 WBZ | 14BC14 | 1410-61 | 7/8 | 3.33 | .87 | 2.09 | 2.53 | .47 | 1.69 | 1-3/8 | 1-9/64 | 15/16 |
| 16-16 WBZ | 16BC16 | 1610-61 | 1 | 3.78 | 1.05 | 2.27 | 2.81 | .56 | 1.78 | 1-5/8 | 1-21/64 | 15/16 |

NOTE: For reducer sizes call out short end first.

Dimensions for reference only, subject to change.

A, C₁ and C₂ dimensions are typical finger-tight.
For replacement bulkhead nuts, see page 74, Part WLZ.

Bulkhead Union For metric tube

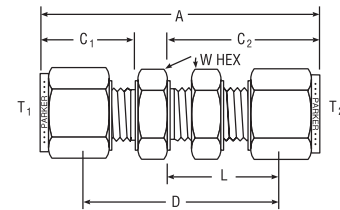
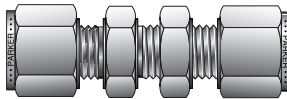

| CPI™ PART NO. | A-LOK® PART NO. | INTER- CHANGES WITH | MILLIMETERS | | | | | | | | |
|------------------|--------------------|---------------------------|--------------|------|----------------|----------------|------|------|----------|---------------------------------|--------------------------|
| | | | TUBE O.D. | A | C ₁ | C ₂ | D | L | W HEX | B'HEAD HOLE DRILL SIZE | MAX. B'HEAD THICK. |
| WBZ 3-3 | BCM3 | 3MO-61 | 3 | 51,3 | 15,3 | 31,2 | 38,2 | 24,6 | 14,0 | 8,3 | 12,7 |
| WBZ 4-4 | BCM4 | 4MO-61 | 4 | 53,7 | 16,1 | 32,0 | 40,5 | 25,4 | 14,0 | 9,9 | 12,7 |
| WBZ 6-6 | BCM6 | 6MO-61 | 6 | 57,9 | 17,7 | 33,7 | 42,9 | 26,2 | 16,0 | 11,5 | 10,2 |
| WBZ 8-8 | BCM8 | 8MO-61 | 8 | 61,0 | 18,6 | 36,0 | 46,0 | 28,5 | 18,0 | 13,1 | 11,2 |
| WBZ 10-10 | BCM10 | 10MO-61 | 10 | 63,6 | 19,5 | 37,0 | 48,4 | 29,4 | 22,0 | 16,3 | 11,2 |
| WBZ 12-12 | BCM12 | 12MO-61 | 12 | 71,0 | 22,0 | 41,9 | 50,8 | 31,8 | 24,0 | 19,5 | 12,7 |
| WBZ 15-15 | BCM15 | 15MO-61 | 15 | 72,5 | 22,0 | 42,6 | 52,3 | 32,5 | 27,0 | 22,5 | 12,7 |
| WBZ 16-16 | BCM16 | 16MO-61 | 16 | 72,6 | 22,0 | 42,6 | 52,4 | 32,5 | 27,0 | 22,5 | 12,7 |
| WBZ 18-18 | BCM18 | 18MO-61 | 18 | 78,9 | 22,0 | 47,4 | 58,7 | 37,3 | 30,0 | 26,0 | 16,8 |
| WBZ 20-20 | BCM20 | 20MO-61 | 20 | 88,2 | 22,0 | 51,0 | 68,0 | 40,9 | 35,0 | 29,0 | 19,0 |
| WBZ 25-25 | BCM25 | 25MO-61 | 25 | 95,8 | 26,5 | 54,4 | 71,4 | 42,2 | 41,0 | 33,8 | 24,0 |

NOTE: A, C₁ and C₂ dimensions are typical finger-tight.

Dimensions for reference only, subject to change.

For replacement bulkhead nuts, see page 74, Part BN.
For reducer sizes call out short end first.

Color Coding

For easy reference, table column headings are color indicated as follows:

fractional

metric



Dielectric Union Adapter For fractional tube

includes nuts, machined tube with molded PEEK¹⁾ insulator, preset ferrule, and dielectric identification ring

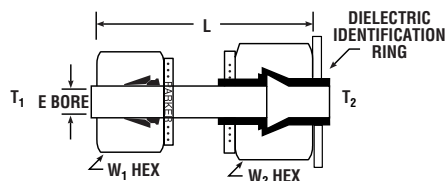
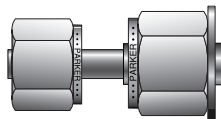

| CPI™ ADAPTER PART NO. | A-LOK® ADAPTER PART NO. | INCHES | | | | | | PRESSURE RATING @ 70°F LIQUID / GAS (PSI) |
|-----------------------|-------------------------|-------------------------|-------------------------|------|--------|--------|--------|---|
| | | T ₁ TUBE END | T ₂ TUBE END | L | E BORE | W1 HEX | W2 HEX | |
| 6-8 DEBTA-SS | 6-8 DELTA | 3/8 | 1/2 | 2.08 | .30 | 11/16 | 7/8 | 4000 / 3000 |
| 8-10 DEBTA-SS | N/A | 1/2 | 5/8 | 2.58 | .38 | 7/8 | 1 | 3000 / 2000 |

*Other end connectors available upon request.

Dimensions for reference only, subject to change.

1) Polyetherether Ketone

NOTE: Makeup instructions included with parts in box when ordered as an Adapter only.

Dielectric Resistivity 10x10⁹ OHMS @ 500 volts DC (Tested on Mil-STD-202F)

Dielectric withstanding voltage less than 100 microamps leakage @ 1500 volts AC

| AMBIENT TEMPERATURE, °F | -40 | -20 | 0 | 20 | 40 | 60 | 80 | 100 | 120 | 140 | 160 | 180 | 200 |
|-----------------------------|------|------|------|------|------|------|------|------|------|------|------|------|------|
| TEMPERATURE DERATING FACTOR | 1.00 | 1.00 | 1.00 | 1.00 | 1.00 | 1.00 | 1.00 | 0.93 | 0.86 | 0.79 | 0.72 | 0.64 | 0.56 |

Dielectric Assembly For fractional tube

includes dielectric union adapter with assembled tube fitting unions

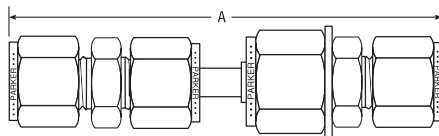
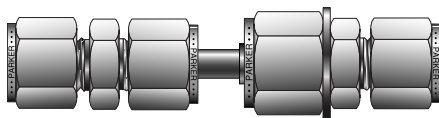

| CPI™ ASSEMBLY PART NO. | A-LOK® ASSEMBLY PART NO. | INCHES | END ADAPTORS |
|------------------------|--------------------------|--------|----------------|
| *COMPRESSION | *COMPRESSION | A† | |
| 4H DEBTA | 4H DELTA | 4.08 | 6RU4/8RU4 |
| 6H DEBTA | 6H DELTA | 4.20 | 6SC6/8RU6 |
| 8H DEBTA | 8H DELTA | 4.79 | 8SC8/10RU8 |
| FEMALE PIPE | FEMALE PIPE | A | END ADAPTORS |
| 4G DEBTA | 4G DELTA | 3.59 | 6FSC4N/8FSC4N |
| 6G DEBTA | 6G DELTA | 3.71 | 6FSC6N/8FSC6N |
| 8G DEBTA | 8G DELTA | 4.40 | 8FSC8N/10FSC8N |
| MALE PIPE | MALE PIPE | A | END ADAPTORS |
| 4F DEBTA | 4F DELTA | 3.80 | 6MSC4N/8MSC4N |
| 6F DEBTA | 6F DELTA | 3.80 | 6MSC6N/8MSC6N |
| 8F DEBTA | 8F DELTA | 4.58 | 8MSC8N/10MSC8N |

†Finger tight assembly dimensions.

Dimensions for reference only, subject to change.

Union Elbow For fractional tube

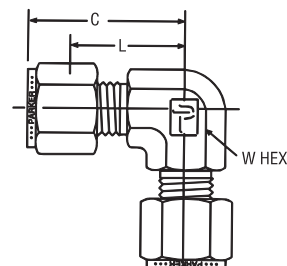
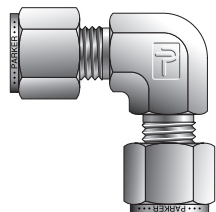

| CPI™ PART NO. | A-LOK® PART NO. | INTER-CHANGES WITH | INCHES | | | |
|---------------|-----------------|--------------------|------------|------|------|---------|
| | | | TUBE O. D. | C | L | W HEX |
| 1-1 EBZ | 1EE1 | 100-9 | 1/16 | .70 | .55 | 3/8 |
| 2-2 EBZ | 2EE2 | 200-9 | 1/8 | .88 | .62 | 3/8 |
| 3-3 EBZ | 3EE3 | 300-9 | 3/16 | 1.00 | .74 | 1/2 |
| 4-4 EBZ | 4EE4 | 400-9 | 1/4 | 1.06 | .77 | 1/2 |
| 5-5 EBZ | 5EE5 | 500-9 | 5/16 | 1.13 | .84 | 9/16 |
| 6-6 EBZ | 6EE6 | 600-9 | 3/8 | 1.20 | .91 | 5/8 |
| 8-8 EBZ | 8EE8 | 810-9 | 1/2 | 1.42 | 1.02 | 13/16 |
| 10-10 EBZ | 10EE10 | 1010-9 | 5/8 | 1.50 | 1.10 | 15/16 |
| 12-12 EBZ | 12EE12 | 1210-9 | 3/4 | 1.57 | 1.17 | 1-1/16 |
| 14-14 EBZ | 14EE14 | 1410-9 | 7/8 | 1.76 | 1.36 | 1-3/8 |
| 16-16 EBZ | 16EE16 | 1610-9 | 1 | 1.93 | 1.45 | 1-3/8 |
| 20-20 EBZ | 20EE20 | 2010-9 | 1-1/4 | 2.61 | 1.75 | 1-5/8 |
| 24-24 EBZ | 24EE24 | 2410-9 | 1-1/2 | 3.06 | 2.00 | 1-7/8 |
| 32-32 EBZ | 32EE32 | 3210-9 | 2 | 4.22 | 2.75 | 2-13/16 |

NOTE: C dimension is typical finger-tight.

Dimensions for reference only, subject to change.

Sizes 20, 24, 32 require additional lubrication prior to assembly.

Union Elbow For metric tube

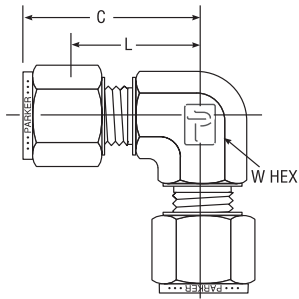
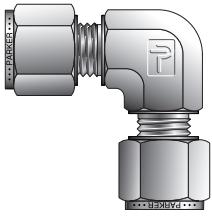

| CPI™ PART NO. | A-LOK® PART NO. | INTER- CHANGES WITH | MILLIMETERS | | | INCHES |
|------------------|--------------------|---------------------------|--------------|------|------|----------|
| | | | TUBE O.D. | C | L | W HEX |
| EBZ 3-3 | EEM3 | 3MO-9 | 3 | 22,3 | 15,7 | 3/8 |
| EBZ 4-4 | EEM4 | 4MO-9 | 4 | 25,4 | 18,8 | 1/2 |
| EBZ 6-6 | EEM6 | 6MO-9 | 6 | 27,0 | 19,6 | 1/2 |
| EBZ 8-8 | EEM8 | 8MO-9 | 8 | 28,8 | 21,3 | 9/16 |
| EBZ 10-10 | EEM10 | 10MO-9 | 10 | 31,5 | 23,9 | 11/16 |
| EBZ 12-12 | EEM12 | 12MO-9 | 12 | 36,0 | 25,9 | 13/16 |
| EBZ 14-14 | EEM14 | 14MO-9 | 14 | 38,1 | 28,0 | 15/16 |
| EBZ 15-15 | EEM15 | 15MO-9 | 15 | 38,0 | 27,9 | 15/16 |
| EBZ 16-16 | EEM16 | 16MO-9 | 16 | 38,0 | 27,9 | 15/16 |
| EBZ 18-18 | EEM18 | 18MO-9 | 18 | 39,8 | 29,7 | 1-1/16 |
| EBZ 20-20 | EEM20 | 20MO-9 | 20 | 44,6 | 34,5 | 1-3/8 |
| EBZ 22-22 | EEM22 | 22MO-9 | 22 | 44,6 | 34,5 | 1-3/8 |
| EBZ 25-25 | EEM25 | 25MO-9 | 25 | 49,1 | 36,8 | 1-3/8 |

NOTE: C dimension is typical finger-tight.

Dimensions for reference only, subject to change.

Drop Size Elbows For fractional tube

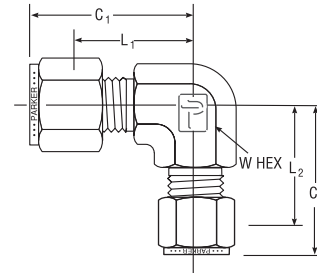
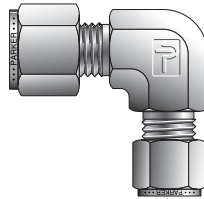

| CPI™ PART NO. | A-LOK® PART NO. | INTER- CHANGES WITH | INCHES | | | | | W HEX |
|------------------|--------------------|---------------------------|--------------|----------------|----------------|----------------|----------------|----------|
| | | | TUBE O.D. | L ₁ | C ₁ | L ₂ | C ₂ | |
| 3-2 EBZ | 3-2 ELZ | 300-9-2 | 3/16-1/8 | 0.74 | 1.01 | 0.70 | 0.96 | 1/2 |
| 4-2 EBZ | 4-2 ELZ | 400-9-2 | 1/4-1/8 | 0.77 | 1.06 | 0.70 | 0.96 | 1/2 |
| 5-2 EBZ | 5-2 ELZ | 500-9-2 | 5/16-1/8 | 0.88 | 1.17 | 0.78 | 1.04 | 5/8 |
| 5-4 EBZ | 5-4 ELZ | 500-9-4 | 5/16-1/4 | 0.88 | 1.17 | 0.85 | 1.14 | 5/8 |
| 6-2 EBZ | 6-2 ELZ | 600-9-2 | 3/8-1/8 | 0.91 | 1.20 | 0.78 | 1.04 | 5/8 |
| 6-4 EBZ | 6-4 ELZ | 600-9-4 | 3/8-1/4 | 0.91 | 1.20 | 0.85 | 1.17 | 5/8 |
| 6-5 EBZ | 6-5 ELZ | 600-9-5 | 3/8-5/16 | 0.91 | 1.20 | 0.88 | 1.17 | 5/8 |
| 8-4 EBZ | 8-4 ELZ | 810-9-4 | 1/2-1/4 | 1.02 | 1.42 | 0.96 | 1.25 | 13/16 |
| 8-5 EBZ | 8-5 ELZ | 810-9-5 | 1/2-5/16 | 1.02 | 1.42 | 0.99 | 1.28 | 13/16 |
| 8-6 EBZ | 8-6 ELZ | 810-9-6 | 1/2-3/8 | 1.02 | 1.42 | 1.02 | 1.31 | 13/16 |
| 10-6 EBZ | 10-6 ELZ | 1010-9-6 | 5/8-3/8 | 1.10 | 1.50 | 1.10 | 1.39 | 15/16 |
| 10-8 EBZ | 10-8 ELZ | 1010-9-8 | 5/8-1/2 | 1.10 | 1.50 | 1.10 | 1.50 | 15/16 |
| 12-4 EBZ | 12-4 ELZ | 1210-9-4 | 3/4-1/4 | 1.16 | 1.56 | 1.10 | 1.39 | 1-1/16 |
| 12-6 EBZ | 12-6 ELZ | 1210-9-6 | 3/4-3/8 | 1.16 | 1.56 | 1.16 | 1.45 | 1-1/16 |
| 12-8 EBZ | 12-8 ELZ | 1210-9-8 | 3/4-1/2 | 1.16 | 1.56 | 1.16 | 1.56 | 1-1/16 |
| 14-4 EBZ | 14-4 ELZ | 1410-9-4 | 7/8-1/4 | 1.36 | 1.76 | 1.30 | 1.59 | 1-3/8 |
| 16-8 EBZ | 16-8 ELZ | 1610-9-8 | 1-1/2 | 1.45 | 1.94 | 1.36 | 1.76 | 1-3/8 |
| 16-12 EBZ | 16-12 ELZ | 1610-9-12 | 1-3/4 | 1.45 | 1.94 | 1.36 | 1.76 | 1-3/8 |

NOTE: C dimension is typical finger-tight.

Dimensions for reference only, subject to change.

Color Coding

For easy reference, table column headings are color indicated as follows:

fractional



metric



Union Tee For fractional tube

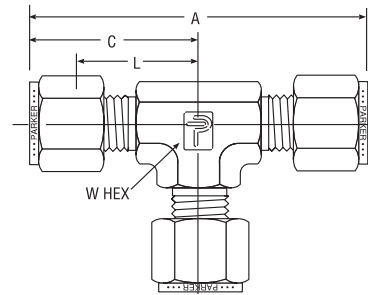
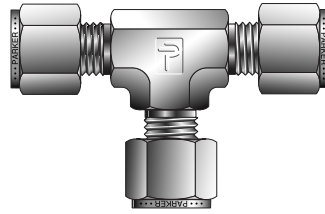

| CPI™ PART NO. | A-LOK® PART NO. | INTER- CHANGES WITH | INCHES | | | | |
|------------------|--------------------|---------------------------|--------------|------|------|------|----------|
| | | | TUBE O.D. | A | C | L | W HEX |
| 1-1-1 JBZ | 1ET1 | 100-3 | 1/16 | 1.42 | 0.71 | 0.56 | 3/8 |
| 2-2-2 JBZ | 2ET2 | 200-3 | 1/8 | 1.76 | 0.88 | 0.62 | 3/8 |
| 3-3-3 JBZ | 3ET3 | 300-3 | 3/16 | 1.96 | 0.96 | 0.70 | 7/16 |
| 4-4-4 JBZ | 4ET4 | 400-3 | 1/4 | 2.12 | 1.06 | 0.77 | 1/2 |
| 5-5-5 JBZ | 5ET5 | 500-3 | 5/16 | 2.34 | 1.17 | 0.88 | 5/8 |
| 6-6-6 JBZ | 6ET6 | 600-3 | 3/8 | 2.40 | 1.20 | 0.91 | 5/8 |
| 8-8-8 JBZ | 8ET8 | 810-3 | 1/2 | 2.84 | 1.42 | 1.02 | 13/16 |
| 10-10-10 JBZ | 10ET10 | 1010-3 | 5/8 | 3.06 | 1.53 | 1.13 | 1 |
| 12-12-12 JBZ | 12ET12 | 1210-3 | 3/4 | 3.14 | 1.57 | 1.16 | 1-1/16 |
| 14-14-14 JBZ | 14ET14 | 1410-3 | 7/8 | 3.52 | 1.76 | 1.36 | 1-3/8 |
| 16-16-16 JBZ | 16ET16 | 1610-3 | 1 | 3.86 | 1.93 | 1.45 | 1-3/8 |
| 20-20-20 JBZ | 20ET20 | 2010-3 | 1-1/4 | 5.22 | 2.61 | 1.75 | 1-5/8 |
| 24-24-24 JBZ | 24ET24 | 2410-3 | 1-1/2 | 6.12 | 3.06 | 2.00 | 1-7/8 |
| 32-32-32 JBZ | 32ET32 | 3210-3 | 2 | 8.44 | 4.22 | 2.75 | 2-13/16 |

NOTE: A and C dimensions are typical finger-tight.

Dimensions for reference only, subject to change.

Sizes 20, 24, 32 require additional lubrication prior to assembly.

Union Tee For metric tube

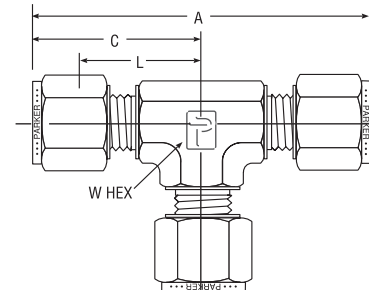
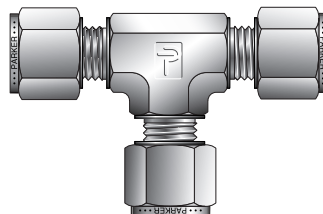

| CPI™ PART NO. | A-LOK® PART NO. | INTER- CHANGES WITH | MILLIMETERS | | | | INCHES |
|------------------|--------------------|---------------------------|--------------|------|------|------|----------|
| | | | TUBE O.D. | A | C | L | W HEX |
| JBZ 2-2-2 | ETM2 | 2MO-3 | 2 | 44,7 | 22,3 | 15,7 | 3/8 |
| JBZ 3-3-3 | ETM3 | 3MO-3 | 3 | 44,7 | 22,3 | 15,7 | 3/8 |
| JBZ 4-4-4 | ETM4 | 4MO-3 | 4 | 50,8 | 25,4 | 18,8 | 1/2 |
| JBZ 6-6-6 | ETM6 | 6MO-3 | 6 | 53,9 | 27,0 | 19,6 | 1/2 |
| JBZ 8-8-8 | ETM8 | 8MO-3 | 8 | 59,7 | 29,9 | 22,4 | 5/8 |
| JBZ 10-10-10 | ETM10 | 10MO-3 | 10 | 63,0 | 31,5 | 23,9 | 11/16 |
| JBZ 12-12-12 | ETM12 | 12MO-3 | 12 | 72,0 | 36,0 | 25,9 | 13/16 |
| JBZ 14-14-14 | ETM14 | 14MO-3 | 14 | 77,6 | 38,8 | 28,7 | 1 |
| JBZ 15-15-15 | ETM15 | 15MO-3 | 15 | 77,6 | 38,8 | 28,7 | 1 |
| JBZ 16-16-16 | ETM16 | 16MO-3 | 16 | 77,6 | 38,8 | 28,7 | 1 |
| JBZ 18-18-18 | ETM18 | 18MO-3 | 18 | 79,5 | 38,8 | 29,7 | 1-1/16 |
| JBZ 20-20-20 | ETM20 | 20MO-3 | 20 | 89,3 | 44,6 | 34,5 | 1-3/8 |
| JBZ 22-22-22 | ETM22 | 22MO-3 | 22 | 89,3 | 44,6 | 34,5 | 1-3/8 |
| JBZ 25-25-25 | ETM25 | 25MO-3 | 25 | 98,3 | 49,1 | 36,8 | 1-3/8 |

NOTE: A and C dimensions are typical finger-tight.

Dimensions for reference only, subject to change.

Drop Size Tees

For fractional tube

Eliminates the extra connection when adapting with a tube stub reducer

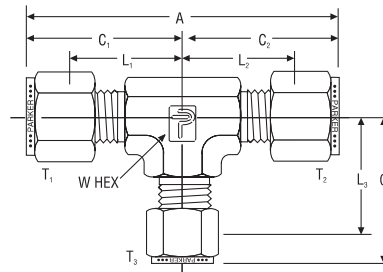
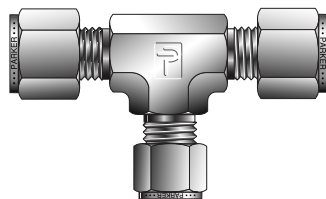

| CPT™ PART NO. | A-LOK® PART NO. | INTER-CHANGES WITH | INCHES | | | | | | | | | | |
|---------------|-----------------|--------------------|--------------------------|--------------------------|--------------------------|------|----------------|----------------|----------------|----------------|----------------|----------------|--------|
| | | | T ₁ TUBE O.D. | T ₂ TUBE O.D. | T ₃ TUBE O.D. | A | L ₁ | C ₁ | L ₂ | C ₂ | L ₃ | C ₃ | W HEX |
| 4-4-2 JBZ | 4-4-2 JLZ | 400-3-4-2 | 1/4 | 1/4 | 1/8 | 2.10 | 0.76 | 1.05 | 0.76 | 1.05 | 0.70 | 0.96 | 1/2 |
| 6-6-4 JBZ | 6-6-4 JLZ | 600-3-6-4 | 3/8 | 3/8 | 1/4 | 2.40 | 0.91 | 1.20 | 0.91 | 1.20 | 0.85 | 1.14 | 5/8 |
| 6-4-6 JBZ | 6-4-6 JLZ | 600-3-4-6 | 3/8 | 1/4 | 3/8 | 2.34 | 0.91 | 1.20 | 0.85 | 1.14 | 0.91 | 1.20 | 5/8 |
| 6-4-4 JBZ | 6-4-4 JLZ | 600-3-4-4 | 3/8 | 1/4 | 1/4 | 2.34 | 0.91 | 1.20 | 0.85 | 1.14 | 0.85 | 1.14 | 5/8 |
| 8-8-6 JBZ | 8-8-6 JLZ | 810-3-8-6 | 1/2 | 1/2 | 3/8 | 2.84 | 1.02 | 1.42 | 1.02 | 1.42 | 1.02 | 1.31 | 13/16 |
| 8-8-4 JBZ | 8-8-4 JLZ | 810-3-8-4 | 1/2 | 1/2 | 1/4 | 2.84 | 1.02 | 1.42 | 1.02 | 1.42 | 0.96 | 1.25 | 13/16 |
| 8-6-8 JBZ | 8-6-8 JLZ | 810-3-6-8 | 1/2 | 3/8 | 1/2 | 2.73 | 1.02 | 1.42 | 1.02 | 1.31 | 1.02 | 1.42 | 13/16 |
| 8-4-8 JBZ | 8-4-8 JLZ | 810-3-4-8 | 1/2 | 1/4 | 1/2 | 2.67 | 1.02 | 1.42 | 0.96 | 1.25 | 1.02 | 1.42 | 13/16 |
| 8-6-6 JBZ | 8-6-6 JLZ | 810-3-6-6 | 1/2 | 3/8 | 3/8 | 2.73 | 1.02 | 1.42 | 1.02 | 1.31 | 1.02 | 1.31 | 13/16 |
| 8-4-4 JBZ | 8-4-4 JLZ | 810-3-4-4 | 1/2 | 1/4 | 1/4 | 2.67 | 1.02 | 1.42 | .96 | 1.25 | .96 | 1.25 | 13/16 |
| 10-10-8 JBZ | 10-10-8 JLZ | 1010-3-10-8 | 5/8 | 5/8 | 1/2 | 3.06 | 1.13 | 1.53 | 1.13 | 1.53 | 1.13 | 1.53 | 7/8 |
| 10-10-6 JBZ | 10-10-6 JLZ | 1010-3-10-6 | 5/8 | 5/8 | 3/8 | 3.06 | 1.13 | 1.53 | 1.13 | 1.53 | 1.13 | 1.53 | 7/8 |
| 10-8-8 JBZ | 10-8-8 JLZ | 1010-3-8-8 | 5/8 | 1/2 | 1/2 | 3.06 | 1.13 | 1.53 | 1.13 | 1.53 | 1.13 | 1.53 | 7/8 |
| 10-8-6 JBZ | 10-8-6 JLZ | 1010-3-8-6 | 5/8 | 1/2 | 3/8 | 3.06 | 1.13 | 1.53 | 1.13 | 1.53 | 1.13 | 1.42 | 7/8 |
| 10-6-6 JBZ | 10-6-6 JLZ | 1010-3-6-6 | 5/8 | 3/8 | 3/8 | 2.95 | 1.13 | 1.53 | 1.13 | 1.42 | 1.13 | 1.42 | 7/8 |
| 10-6-8 JBZ | 10-6-8 JLZ | 1010-3-6-8 | 5/8 | 3/8 | 1/2 | 2.95 | 1.13 | 1.53 | 1.13 | 1.42 | 1.13 | 1.53 | 7/8 |
| 12-12-10 JBZ | 12-12-10 JLZ | 1210-3-12-10 | 3/4 | 3/4 | 5/8 | 3.12 | 1.16 | 1.56 | 1.16 | 1.56 | 1.16 | 1.56 | 1-1/16 |
| 12-12-8 JBZ | 12-12-8 JLZ | 1210-3-12-8 | 3/4 | 3/4 | 1/2 | 3.12 | 1.16 | 1.56 | 1.16 | 1.56 | 1.16 | 1.56 | 1-1/16 |
| 12-12-6 JBZ | 12-12-6 JLZ | 1210-3-12-6 | 3/4 | 3/4 | 3/8 | 3.12 | 1.16 | 1.56 | 1.16 | 1.56 | 1.16 | 1.45 | 1-1/16 |
| 12-12-4 JBZ | 12-12-4 JLZ | 1210-3-12-4 | 3/4 | 3/4 | 1/4 | 3.12 | 1.16 | 1.56 | 1.16 | 1.56 | 1.10 | 1.39 | 1-1/16 |
| 12-10-10 JBZ | 12-10-10 JLZ | 1210-3-10-10 | 3/4 | 5/8 | 5/8 | 3.12 | 1.16 | 1.56 | 1.16 | 1.56 | 1.16 | 1.56 | 1-1/16 |
| 12-8-8 JBZ | 12-8-8 JLZ | 1210-3-8-8 | 3/4 | 1/2 | 1/2 | 3.12 | 1.16 | 1.56 | 1.16 | 1.56 | 1.16 | 1.56 | 1-1/16 |
| 12-6-6 JBZ | 12-6-6 JLZ | 1210-3-6-6 | 3/4 | 3/8 | 3/8 | 3.01 | 1.16 | 1.56 | 1.16 | 1.45 | 1.16 | 1.45 | 1-1/16 |
| 12-10-8 JBZ | 12-10-8 JLZ | 1210-3-10-8 | 3/4 | 5/8 | 1/2 | 3.12 | 1.16 | 1.56 | 1.16 | 1.56 | 1.16 | 1.56 | 1-1/16 |
| 12-10-6 JBZ | 12-10-6 JLZ | 1210-3-10-6 | 3/4 | 5/8 | 3/8 | 3.12 | 1.16 | 1.56 | 1.16 | 1.56 | 1.16 | 1.45 | 1-1/16 |
| 12-8-6 JBZ | 12-8-6 JLZ | 1210-3-8-6 | 3/4 | 1/2 | 3/8 | 3.12 | 1.16 | 1.56 | 1.16 | 1.56 | 1.16 | 1.45 | 1-1/16 |
| 14-14-6 JBZ | 14-14-6 JLZ | 1410-3-14-6 | 7/8 | 7/8 | 3/8 | 3.52 | 1.36 | 1.76 | 1.36 | 1.76 | 1.36 | 1.65 | 1-3/8 |
| 14-14-4 JBZ | 14-14-4 JLZ | 1410-3-14-4 | 7/8 | 7/8 | 1/4 | 3.52 | 1.36 | 1.76 | 1.36 | 1.76 | 1.30 | 1.59 | 1-3/8 |
| 14-12-12 JBZ | 14-12-12 JLZ | 1410-3-12-12 | 7/8 | 3/4 | 3/4 | 3.52 | 1.36 | 1.76 | 1.36 | 1.76 | 1.36 | 1.76 | 1-3/8 |
| 14-12-8 JBZ | 14-12-8 JLZ | 1410-3-12-8 | 7/8 | 3/4 | 1/2 | 3.52 | 1.36 | 1.76 | 1.36 | 1.76 | 1.36 | 1.76 | 1-3/8 |
| 14-12-6 JBZ | 14-12-6 JLZ | 1410-3-12-6 | 7/8 | 3/4 | 3/8 | 3.52 | 1.36 | 1.76 | 1.36 | 1.76 | 1.36 | 1.65 | 1-3/8 |
| 14-10-6 JBZ | 14-10-6 JLZ | 1410-3-10-6 | 7/8 | 5/8 | 3/8 | 3.52 | 1.36 | 1.76 | 1.36 | 1.76 | 1.36 | 1.65 | 1-3/8 |
| 14-8-12 JBZ | 14-8-12 JLZ | 1410-3-8-12 | 7/8 | 1/2 | 3/4 | 3.52 | 1.36 | 1.76 | 1.36 | 1.76 | 1.36 | 1.76 | 1-3/8 |
| 16-16-12 JBZ | 16-16-12 JLZ | 1610-3-16-12 | 1 | 1 | 3/4 | 3.88 | 1.45 | 1.94 | 1.45 | 1.94 | 1.36 | 1.76 | 1-3/8 |
| 16-16-10 JBZ | 16-16-10 JLZ | 1610-3-16-10 | 1 | 1 | 5/8 | 3.88 | 1.45 | 1.94 | 1.45 | 1.94 | 1.36 | 1.76 | 1-3/8 |
| 16-16-8 JBZ | 16-16-8 JLZ | 1610-3-16-8 | 1 | 1 | 1/2 | 3.88 | 1.45 | 1.94 | 1.45 | 1.94 | 1.36 | 1.76 | 1-3/8 |
| 16-16-6 JBZ | 16-16-6 JLZ | 1610-3-16-6 | 1 | 1 | 3/8 | 3.88 | 1.45 | 1.94 | 1.45 | 1.94 | 1.36 | 1.65 | 1-3/8 |
| 16-16-4 JBZ | 16-16-4 JLZ | 1610-3-16-4 | 1 | 1 | 1/4 | 3.88 | 1.45 | 1.94 | 1.45 | 1.94 | 1.30 | 1.59 | 1-3/8 |
| 16-12-16 JBZ | 16-12-16 JLZ | 1610-3-12-16 | 1 | 3/4 | 1 | 3.70 | 1.45 | 1.94 | 1.36 | 1.76 | 1.45 | 1.94 | 1-3/8 |
| 16-14-14 JBZ | 16-14-14 JLZ | 1610-3-14-14 | 1 | 7/8 | 7/8 | 3.70 | 1.45 | 1.94 | 1.36 | 1.76 | 1.36 | 1.76 | 1-3/8 |
| 16-14-12 JBZ | 16-14-12 JLZ | 1610-3-14-12 | 1 | 7/8 | 3/4 | 3.70 | 1.45 | 1.94 | 1.36 | 1.76 | 1.36 | 1.76 | 1-3/8 |
| 16-14-8 JBZ | 16-14-8 JLZ | 1610-3-14-8 | 1 | 7/8 | 1/2 | 3.70 | 1.45 | 1.94 | 1.36 | 1.76 | 1.36 | 1.76 | 1-3/8 |
| 16-14-6 JBZ | 16-14-6 JLZ | 1610-3-14-6 | 1 | 7/8 | 3/8 | 3.70 | 1.45 | 1.94 | 1.36 | 1.76 | 1.36 | 1.65 | 1-3/8 |
| 16-14-4 JBZ | 16-14-4 JLZ | 1610-3-14-4 | 1 | 7/8 | 1/4 | 3.70 | 1.45 | 1.94 | 1.36 | 1.76 | 1.30 | 1.59 | 1-3/8 |
| 16-16-14 JBZ | 16-16-14 JLZ | 1610-3-16-14 | 1 | 1 | 7/8 | 3.88 | 1.45 | 1.94 | 1.45 | 1.94 | 1.36 | 1.76 | 1-3/8 |
| 16-12-10 JBZ | 16-12-10 JLZ | 1610-3-12-10 | 1 | 3/4 | 5/8 | 3.70 | 1.45 | 1.94 | 1.36 | 1.76 | 1.36 | 1.76 | 1-3/8 |
| 16-12-8 JBZ | 16-12-8 JLZ | 1610-3-12-8 | 1 | 3/4 | 1/2 | 3.70 | 1.45 | 1.94 | 1.36 | 1.76 | 1.36 | 1.76 | 1-3/8 |
| 16-10-6 JBZ | 16-10-6 JLZ | 1610-3-10-6 | 1 | 5/8 | 3/8 | 3.70 | 1.45 | 1.94 | 1.36 | 1.76 | 1.36 | 1.65 | 1-3/8 |
| 16-8-16 JBZ | 16-8-16 JLZ | 1610-3-8-16 | 1 | 1/2 | 1 | 3.70 | 1.45 | 1.94 | 1.36 | 1.76 | 1.45 | 1.94 | 1-3/8 |
| 16-8-8 JBZ | 16-8-8 JLZ | 1610-3-8-8 | 1 | 1/2 | 1/2 | 3.70 | 1.45 | 1.94 | 1.36 | 1.76 | 1.36 | 1.76 | 1-3/8 |
| 16-8-6 JBZ | 16-8-6 JLZ | 1610-3-8-6 | 1 | 1/2 | 3/8 | 3.70 | 1.45 | 1.94 | 1.36 | 1.76 | 1.36 | 1.65 | 1-3/8 |
| 16-8-4 JBZ | 16-8-4 JLZ | 1610-3-8-4 | 1 | 1/2 | 1/4 | 3.70 | 1.45 | 1.94 | 1.36 | 1.76 | 1.30 | 1.59 | 1-3/8 |
| 16-6-6 JBZ | 16-6-6 JLZ | 1610-3-6-6 | 1 | 3/8 | 3/8 | 3.59 | 1.45 | 1.94 | 1.36 | 1.65 | 1.36 | 1.65 | 1-3/8 |

NOTE: C dimensions are typical finger-tight.

Dimensions for reference only, subject to change.



Union Cross For fractional tube

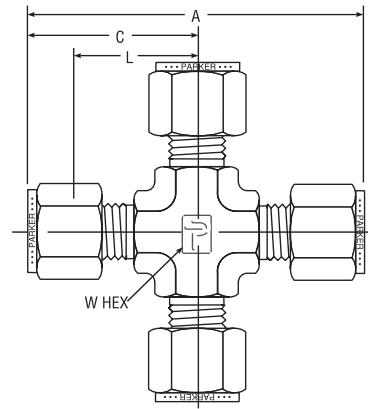
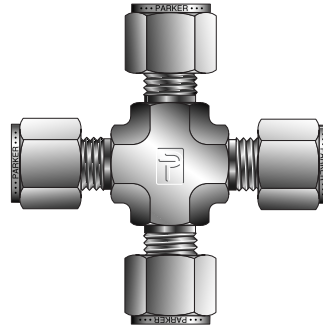

| CPI™ PART NO. | A-LOK® PART NO. | INTER- CHANGES WITH | INCHES | | | | |
|------------------|--------------------|---------------------------|--------------|------|------|------|----------|
| | | | TUBE O.D. | A | C | L | W HEX |
| 2 KBZ | 2ECR2 | 200-4 | 1/8 | 1.76 | 0.98 | 0.62 | 7/16 |
| 3 KBZ | 3ECR3 | 300-4 | 3/16 | 1.83 | 0.96 | 0.70 | 7/16 |
| 4 KBZ | 4ECR4 | 400-4 | 1/4 | 2.12 | 1.06 | 0.76 | 1/2 |
| 5 KBZ | 5ECR5 | 500-4 | 5/16 | 2.34 | 1.17 | 0.88 | 5/8 |
| 6 KBZ | 6ECR6 | 600-4 | 3/8 | 2.40 | 1.20 | 0.91 | 5/8 |
| 8 KBZ | 8ECR8 | 810-4 | 1/2 | 2.84 | 1.42 | 1.02 | 13/16 |
| 10 KBZ | 10ECR10 | 1010-4 | 5/8 | 3.06 | 1.53 | 1.13 | 1-1/16 |
| 12 KBZ | 12ECR12 | 1210-4 | 3/4 | 3.12 | 1.57 | 1.16 | 1-1/16 |
| 14 KBZ | 14ECR14 | 1410-4 | 7/8 | 3.52 | 1.76 | 1.36 | 1-5/16 |
| 16 KBZ | 16ECR16 | 1610-4 | 1 | 3.86 | 1.93 | 1.45 | 1-5/16 |

NOTE: A and C dimensions are typical finger-tight.

Dimensions for reference only, subject to change.

Union Cross For metric tube

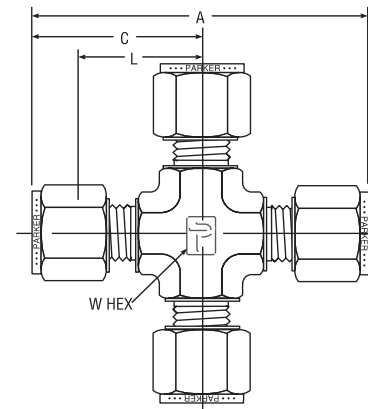
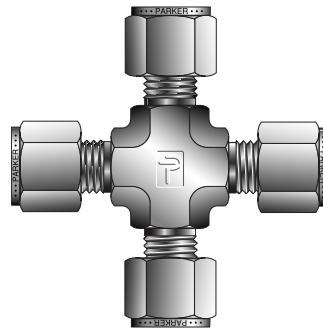

| CPI™ PART NO. | A-LOK® PART NO. | INTER- CHANGES WITH | MILLIMETERS | | | | INCHES |
|------------------|--------------------|---------------------------|--------------|------|------|------|----------|
| | | | TUBE O.D. | A | C | L | W HEX |
| KBZ 3 | ECRM3 | 3MO-4 | 3 | 44,7 | 22,3 | 15,7 | 7/16 |
| KBZ4 | ECRM4 | 4MO-4 | 4 | 50,8 | 25,4 | 18,8 | 1/2 |
| KBZ 6 | ECRM6 | 6MO-4 | 6 | 53,9 | 27,0 | 19,6 | 1/2 |
| KBZ 8 | ECRM8 | 8MO-4 | 8 | 59,7 | 29,9 | 22,4 | 5/8 |
| KBZ 10 | ECRM10 | 10MO-4 | 10 | 67,0 | 33,5 | 25,9 | 13/16 |
| KBZ 12 | ECRM12 | 12MO-4 | 12 | 72,0 | 36,0 | 25,9 | 13/16 |
| KBZ 16 | ECRM16 | 16MO-4 | 16 | 74,0 | 37,0 | 26,9 | 15/16 |
| KBZ 18 | ECRM18 | 18MO-4 | 18 | 76,6 | 38,3 | 28,2 | 1-1/16 |

NOTE: A and C dimensions are typical finger-tight.

Dimensions for reference only, subject to change.

Color Coding

For easy reference, table column headings are color indicated as follows:

fractional



metric



Tube End Reducer For fractional tube

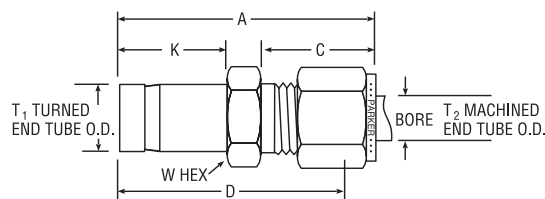
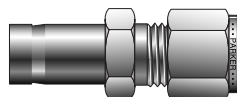

| CPI™ PART NO. | A-LOK® PART NO. | INTER- CHANGES WITH | INCHES | | | | | | | |
|------------------|--------------------|---------------------------|--|--|-------|------|------|------|----------|------|
| | | | T ₁ TURNED END TUBE O.D. | T ₂ MACHINED END TUBE O.D. | A | C | D | K | W HEX | BORE |
| 2-1 TRBZ | 2TUR1 | 100-R-2 | 1/8 | 1/16 | 1.10 | 0.43 | 0.95 | 0.53 | 5/16 | 0.05 |
| 3-1 TRBZ | 3TUR1 | 100-R-3 | 3/16 | 1/16 | 1.13 | 0.43 | 0.98 | 0.58 | 5/16 | 0.05 |
| 4-1 TRBZ | 4TUR1 | 100-R-4 | 1/4 | 1/16 | 1.24 | 0.43 | 1.09 | 0.63 | 7/16 | 0.05 |
| 1-2 TRBZ | 1TUR2 | 200-R-1 | 1/16 | 1/8 | 1.18 | 0.60 | 0.92 | 0.38 | 7/16 | 0.09 |
| 2-2 TRBZ | 2TUR2 | 200-R-2 | 1/8 | 1/8 | 1.34 | 0.43 | 1.09 | 0.54 | 7/16 | 0.07 |
| 3-2 TRBZ | 3TUR2 | 200-R-3 | 3/16 | 1/8 | 1.35 | 0.60 | 1.09 | 0.58 | 7/16 | 0.09 |
| 4-2 TRBZ | 4TUR2 | 200-R-4 | 1/4 | 1/8 | 1.42 | 0.60 | 1.16 | 0.63 | 7/16 | 0.09 |
| 6-2 TRBZ | 6TUR2 | 200-R-6 | 3/8 | 1/8 | 1.48 | 0.60 | 1.22 | 0.69 | 7/16 | 0.09 |
| 8-2 TRBZ | 8TUR2 | 200-R-8 | 1/2 | 1/8 | 1.74 | 0.60 | 1.48 | 0.91 | 9/16 | 0.09 |
| 2-3 TRBZ | 2TUR3 | 300-R-2 | 1/8 | 3/16 | 1.37 | 0.63 | 1.11 | 0.53 | 7/16 | 0.08 |
| 4-3 TRBZ | 4TUR3 | 300-R-4 | 1/4 | 3/16 | 1.46 | 0.63 | 1.20 | 0.63 | 7/16 | 0.13 |
| 2-4 TRBZ | 2TUR4 | 400-R-2 | 1/8 | 1/4 | 1.45 | 0.70 | 1.16 | 0.53 | 1/2 | 0.08 |
| 3-4 TRBZ | 3TUR4 | 400-R-3 | 3/16 | 1/4 | 1.48 | 0.60 | 1.19 | 0.56 | 1/2 | 0.12 |
| 4-4 TRBZ | 4TUR4 | 400-R-4 | 1/4 | 1/4 | 1.54 | 0.70 | 1.25 | 0.63 | 1/2 | 0.16 |
| 5-4 TRBZ | 5TUR4 | 400-R-5 | 5/16 | 1/4 | 1.57 | 0.70 | 1.28 | 0.66 | 1/2 | 0.16 |
| 6-4 TRBZ | 6TUR4 | 400-R-6 | 3/8 | 1/4 | 1.60 | 0.70 | 1.31 | 0.69 | 1/2 | 0.19 |
| 8-4 TRBZ | 8TUR4 | 400-R-8 | 1/2 | 1/4 | 1.82 | 0.70 | 1.53 | 0.91 | 9/16 | 0.19 |
| 10-4 TRBZ | 10TUR4 | 400-R-10 | 5/8 | 1/4 | 1.89 | 0.70 | 1.60 | 0.97 | 11/16 | 0.19 |
| 12-4 TRBZ | 12TUR4 | 400-R-12 | 3/4 | 1/4 | 1.88 | 0.70 | 1.59 | 0.97 | 13/16 | 0.19 |
| 6-5 TRBZ | 6TUR5 | 500-R-6 | 3/8 | 5/16 | 1.65 | 0.73 | 1.36 | 0.69 | 9/16 | 0.25 |
| 8-5 TRBZ | 8TUR5 | 500-R-8 | 1/2 | 5/16 | 1.87 | 0.73 | 1.58 | 0.91 | 9/16 | 0.25 |
| 4-6 TRBZ | 4TUR6 | 600-R-4 | 1/4 | 3/8 | 1.63 | 0.76 | 1.34 | 0.63 | 5/8 | 0.19 |
| 6-6 TRBZ | 6TUR6 | 600-R-6 | 3/8 | 3/8 | 1.70 | 0.76 | 1.41 | 0.69 | 5/8 | 0.28 |
| 8-6 TRBZ | 8TUR6 | 600-R-8 | 1/2 | 3/8 | 1.91 | 0.76 | 1.62 | 0.91 | 5/8 | 0.28 |
| 10-6 TRBZ | 10TUR6 | 600-R-10 | 5/8 | 3/8 | 1.98 | 0.76 | 1.69 | 0.97 | 11/16 | 0.28 |
| 12-6 TRBZ | 12TUR6 | 600-R-12 | 3/4 | 3/8 | 1.98 | 0.76 | 1.69 | 0.97 | 13/16 | 0.28 |
| 4-8 TRBZ | 4TUR8 | 810-R-4 | 1/4 | 1/2 | 1.77 | 0.87 | 1.37 | 0.63 | 13/16 | 0.19 |
| 6-8 TRBZ | 6TUR8 | 810-R-6 | 3/8 | 1/2 | 1.84 | 0.87 | 1.44 | 0.69 | 13/16 | 0.19 |
| 10-8 TRBZ | 10TUR8 | 810-R-10 | 5/8 | 1/2 | 2.12 | 0.87 | 1.72 | 0.97 | 13/16 | 0.41 |
| 12-8 TRBZ | 12TUR8 | 810-R-12 | 3/4 | 1/2 | 2.12 | 0.87 | 1.72 | 0.97 | 13/16 | 0.41 |
| 16-8 TRBZ | 16TUR8 | 810-R-16 | 1 | 1/2 | 2.37 | 0.87 | 1.97 | 1.22 | 1-1/16 | 0.41 |
| 12-10 TRBZ | 12TUR10 | 1010-R-12 | 3/4 | 5/8 | 2.15 | 0.87 | 1.75 | 0.97 | 15/16 | 0.50 |
| 14-10 TRBZ | 14TUR10 | 1010-R-14 | 7/8 | 5/8 | 2.21 | 0.87 | 1.81 | 1.03 | 15/16 | 0.50 |
| 16-10 TRBZ | 16TUR10 | 1010-R-16 | 1 | 5/8 | 2.40 | 0.87 | 2.00 | 1.22 | 1-1/16 | 0.50 |
| 8-12 TRBZ | 8TUR12 | 1210-R-8 | 1/2 | 3/4 | 2.15 | 0.87 | 1.75 | 0.91 | 1-1/16 | 0.39 |
| 16-12 TRBZ | 16TUR12 | 1210-R-16 | 1 | 3/4 | 2.46 | 0.87 | 2.06 | 1.22 | 1-1/16 | 0.63 |
| 24-16 TRBZ† | 24TUR16 | 1610-R-24 | 1-1/2 | 1 | 3.519 | 1.05 | 3.03 | 2.05 | 1-5/8 | 0.88 |
| 24-20 TRBZ† | 24TUR20 | 2010-R-24 | 1-1/2 | 1-1/4 | 4.10 | 1.52 | 3.23 | 2.05 | 1-7/8 | 1.09 |
| 32-24 TRBZ† | 32TUR24 | 2410-R-32 | 2 | 1-1/2 | 5.17 | 1.52 | 4.10 | 2.74 | 2-1/4 | 1.34 |

NOTE: A and C dimensions are typical finger-tight.

Dimensions for reference only, subject to change.

Size 1, 2, and 3 do not require a groove.

Size 4 and above tube stub is pre-grooved as standard. Generic (non-grooved) can be ordered through Quick Response Department.

Sizes 20, 24 require additional lubrication prior to assembly.

† Add -Z6 for assembly of nuts and ferrules on the tube stub end.

† All tube stubs over 1" come standard with nuts and ferrule(s) pre-assembled (-Z6 option).

Tube End Converter For fractional tube to metric tube

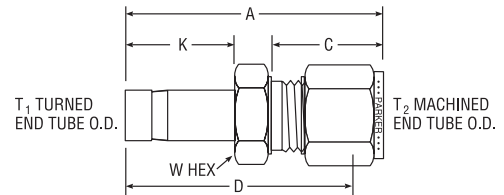
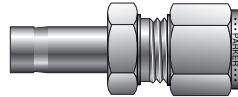

| CPI™ PART NO. | A-LOK® PART NO. | INTER- CHANGES WITH | TUBE O. D. | | MILLIMETERS | | | | | |
|------------------|--------------------|---------------------------|------------------------|----------------------|-------------|------|------|------|--------------|------|
| | | | T ₁ INCH | T ₂ MM | A | C | D | K | W A/F HEX | BORE |
| TRBZ 1/8-3 | 2TUCM3 | 3MO-R-2 | 1/8 | 3 | 34,3 | 15,3 | 27,7 | 13,5 | 12,0 | 1,4 |
| TRBZ 1/4-3 | 4TUCM3 | 3MO-R-4 | 1/4 | 3 | 36,1 | 15,3 | 29,5 | 16,0 | 12,0 | 4,8 |
| TRBZ 1/4-6 | 4TUCM6 | 6MO-R-4 | 1/4 | 6 | 39,3 | 17,7 | 31,8 | 16,0 | 14,0 | 4,8 |
| TRBZ 5/16-6 | 5TUCM6 | 6MO-R-5 | 5/16 | 6 | 40,0 | 17,7 | 32,5 | 16,8 | 14,0 | 6,4 |
| TRBZ 3/8-6 | 6TUCM6 | 6MO-R-6 | 3/8 | 6 | 40,8 | 17,7 | 33,3 | 17,5 | 14,0 | 7,1 |
| TRBZ 1/2-6 | 8TUCM6 | 6MO-R-8 | 1/2 | 6 | 46,4 | 17,7 | 38,9 | 23,1 | 14,0 | 9,9 |
| TRBZ 3/8-8 | 6TUCM8 | 8MO-R-6 | 3/8 | 8 | 42,0 | 18,6 | 34,5 | 17,5 | 15,0 | 7,1 |
| TRBZ 1/2-8 | 8TUCM8 | 8MO-R-8 | 1/2 | 8 | 47,5 | 18,6 | 40,1 | 23,1 | 15,0 | 9,9 |
| TRBZ 3/8-10 | 6TUCM10 | 10MO-R-6 | 3/8 | 10 | 44,4 | 19,5 | 36,8 | 17,5 | 18,0 | 7,1 |
| TRBZ 1/2-10 | 8TUCM10 | 10MO-R-8 | 1/2 | 10 | 47,6 | 19,5 | 41,4 | 23,1 | 18,0 | 9,9 |
| TRBZ 1/2-12 | 8TUCM12 | 12MO-R-8 | 1/2 | 12 | 52,3 | 22,0 | 42,2 | 23,1 | 22,0 | 9,9 |
| TRBZ 3/4-12 | 12TUCM12 | 12MO-R-12 | 3/4 | 12 | 53,8 | 22,0 | 43,7 | 24,6 | 22,0 | 15,1 |
| TRBZ 3/4-18 | 12TUCM18 | 18MO-R-12 | 3/4 | 18 | 57,5 | 22,0 | 47,5 | 24,6 | 27,0 | 15,1 |

NOTE: A and C dimensions are typical finger-tight.

Dimensions for reference only, subject to change.

Tube stub is pre-grooved as standard. Generic (non-grooved) can be ordered through Quick Response Department.

Size 1, 2, and 3 do not require a groove.

Add -Z6 for assembly of nuts and ferrules on the tube stub end.

Color Coding

For easy reference, table column headings are color indicated as follows:

fractional



metric



Tube End Reducer For metric tube

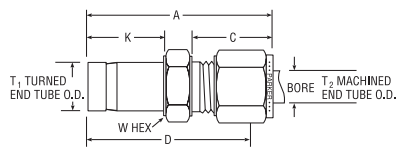
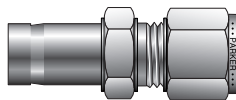

| CPI™ PART NO. | A-LOK® PART NO. | INTER- CHANGES WITH | TUBE O.D. | | MILLIMETERS | | | | | | |
|------------------|--------------------|---------------------------|----------------|----------------|-------------|------|------|------|-----|----------|------|
| | | | T ₁ | T ₂ | A | C | D | K | O | W HEX | BORE |
| TRBZ 3-2 | M3TURM2 | 2MO-R-3M | 3 | 2 | 34,3 | 15,3 | 27,7 | 13,5 | 0,6 | 14,0 | 1,4 |
| TRBZ 3-6 | M3TURM6 | 6MO-R-3M | 3 | 6 | 37,0 | 17,7 | 29,5 | 13,5 | 0,6 | 14,0 | 1,4 |
| TRBZ 4-3 | M4TURM3 | 3MO-R-4M | 4 | 3 | 35,0 | 15,3 | 28,4 | 14,3 | 1,0 | 12,0 | 2,0 |
| TRBZ 6-3 | M6TURM3 | 3MO-R-6M | 6 | 3 | 36,1 | 15,3 | 29,5 | 15,9 | 1,0 | 12,0 | 2,4 |
| TRBZ 6-4 | M6TURM4 | 4MO-R-6M | 6 | 4 | 37,1 | 16,1 | 30,5 | 15,9 | 1,0 | 12,0 | 3,0 |
| TRBZ 6-8 | M6TURM8 | 8MO-R-6M | 6 | 8 | 40,0 | 18,6 | 32,5 | 15,9 | 1,0 | 15,0 | 4,0 |
| TRBZ 6-10 | M6TURM10 | 10MO-R-6M | 6 | 10 | 41,7 | 19,5 | 34,1 | 15,9 | 1,0 | 18,0 | 4,0 |
| TRBZ 6-12 | M6TURM12 | 12MO-R-6M | 6 | 12 | 44,9 | 22,0 | 34,8 | 15,9 | 1,0 | 22,0 | 4,0 |
| TRBZ 8-6 | M8TURM6 | 6MO-R-8M | 8 | 6 | 40,0 | 17,7 | 32,5 | 16,7 | 0,8 | 14,0 | 4,8 |
| TRBZ 8-10 | M8TURM10 | 10MO-R-8M | 8 | 10 | 43,4 | 19,5 | 35,8 | 15,3 | 1,5 | 19,5 | 18,0 |
| TRBZ 10-3 | M10TURM3 | 3MO-R-10M | 10 | 3 | 38,6 | 15,3 | 32,0 | 17,7 | 2,0 | 15,3 | 12,0 |
| TRBZ 10-6 | M10TURM6 | 6MO-R-10M | 10 | 6 | 40,8 | 17,7 | 33,3 | 17,5 | 1,3 | 14,0 | 4,8 |
| TRBZ 10-8 | M10TURM8 | 8MO-R-10M | 10 | 8 | 42,0 | 18,6 | 34,5 | 17,5 | 1,3 | 15,0 | 6,4 |
| TRBZ 10-12 | M10TURM12 | 12MO-R-10M | 10 | 12 | 46,6 | 22,0 | 36,5 | 17,5 | 1,3 | 22,0 | 7,5 |
| TRBZ 12-6 | M12TURM6 | 6MO-R-12M | 12 | 6 | 46,4 | 17,7 | 38,9 | 23,0 | 1,4 | 14,0 | 4,8 |
| TRBZ 12-8 | M12TURM8 | 8MO-R-12M | 12 | 8 | 47,6 | 18,6 | 40,1 | 23,0 | 1,4 | 15,0 | 6,4 |
| TRBZ 12-10 | M12TURM10 | 10MO-R-12M | 12 | 10 | 49,7 | 19,5 | 42,1 | 23,0 | 1,4 | 18,0 | 7,9 |
| TRBZ 12-16 | M12TURM16 | 16MO-R-12M | 12 | 16 | 53,0 | 22,0 | 42,9 | 23,0 | 1,4 | 24,0 | 9,1 |
| TRBZ 12-18 | M12TURM18 | 18MO-R-12M | 12 | 18 | 54,6 | 22,0 | 44,5 | 23,0 | 1,4 | 27,0 | 9,1 |
| TRBZ 15-10 | M15TURM10 | 10MO-R-15M | 15 | 10 | 51,3 | 19,5 | 43,7 | 23,8 | 1,6 | 27,0 | 7,9 |
| TRBZ 16-12 | M16TURM12 | 12MO-R-16M | 16 | 12 | 53,8 | 22,0 | 43,7 | 24,6 | 1,7 | 22,0 | 9,5 |
| TRBZ 16-18 | M16TURM18 | 18MO-R-16M | 16 | 18 | 56,1 | 22,0 | 46,0 | 24,6 | 1,7 | 27,0 | 12,7 |
| TRBZ 16-20 | M16TURM20 | 20MO-R-16M | 16 | 20 | 57,9 | 22,0 | 47,8 | 24,6 | 1,7 | 27,0 | 12,7 |
| TRBZ 16-25 | M16TURM25 | 25MO-R-16M | 16 | 25 | 63,2 | 26,5 | 51,0 | 24,8 | 2,0 | 26,5 | 35,0 |
| TRBZ 18-12 | M18TURM12 | 12MO-R-18M | 18 | 12 | 53,8 | 22,0 | 43,7 | 24,6 | 2,0 | 22,0 | 9,5 |
| TRBZ 18-16 | M18TURM16 | 16MO-R-18M | 18 | 16 | 54,7 | 22,0 | 44,6 | 24,8 | 2,5 | 22,0 | 24,0 |
| TRBZ 18-20 | M18TURM20 | 20MO-R-18M | 18 | 20 | 57,9 | 22,0 | 47,8 | 24,6 | 2,0 | 30,0 | 13,9 |
| TRBZ 18-25 | M18TURM25 | 25MO-R-18M | 18 | 25 | 63,1 | 26,5 | 50,8 | 24,6 | 2,0 | 35,0 | 14,0 |
| TRBZ 20-12 | M20TURM12 | 12MO-R-20M | 20 | 12 | 56,1 | 22,0 | 46,0 | 25,4 | 2,5 | 22,0 | 9,5 |
| TRBZ 20-16 | M20TURM16 | 16MO-R-20M | 20 | 16 | 55,3 | 22,0 | 45,2 | 25,6 | 2,5 | 22,0 | 24,0 |
| TRBZ 20-18 | M20TURM18 | 18MO-R-20M | 20 | 18 | 57,6 | 22,0 | 47,5 | 25,4 | 2,5 | 27,0 | 15,1 |
| TRBZ 20-25 | M20TURM25 | 25MO-R-20M | 20 | 25 | 64,5 | 26,5 | 52,3 | 25,4 | 2,5 | 35,0 | 15,1 |
| TRBZ 22-18 | M22TURM18 | 18MO-R-22M | 22 | 18 | 56,1 | 22,0 | 46,0 | 26,2 | 2,5 | 27,0 | 15,1 |
| TRBZ 22-20 | M22TURM20 | 20MO-R-22M | 22 | 20 | 57,7 | 22,0 | 47,6 | 26,2 | 2,5 | 30,0 | 15,8 |
| TRBZ 25-12 | M25TURM12 | 12MO-R-25M | 25 | 12 | 60,9 | 22,0 | 50,8 | 31,8 | 2,6 | 27,0 | 9,5 |
| TRBZ 25-16 | M25TURM16 | 16MO-R-25M | 25 | 16 | 64,0 | 22,0 | 51,8 | 32,0 | 3,0 | 22,0 | 27,0 |
| TRBZ 25-18 | M25TURM18 | 18MO-R-25M | 25 | 18 | 62,5 | 22,0 | 52,4 | 31,8 | 2,6 | 27,0 | 15,1 |
| TRBZ 25-20 | M25TURM20 | 20MO-R-25M | 25 | 20 | 64,2 | 22,0 | 54,1 | 31,8 | 2,6 | 30,0 | 15,8 |

NOTE: A and C dimensions are typical finger-tight.

Dimensions for reference only, subject to change.

Tube stub is pre-grooved as standard.
Add -Z6 for assembly of nuts and ferrules on the tube stub end.

Color Coding

For easy reference, table column headings are color indicated as follows:

fractional



metric



Tube End Bulkhead Adapter For fractional tube

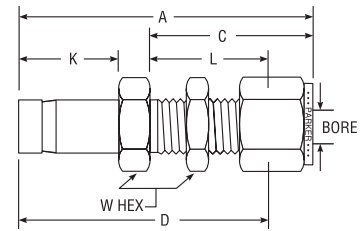
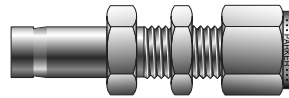

| CPI™ PART NO. | A-LOK® PART NO. | INTER- CHANGES WITH | INCHES | | | | | | | |
|------------------|--------------------|---------------------------|--------------|------|------|------|-----|------|------|----------|
| | | | TUBE O.D. | A | C | L | K | D | BORE | W HEX |
| 2-2 T2H2BZ | 2TUBC2 | 200-R1-2 | 1/8 | 1.95 | 1.23 | 0.97 | .53 | 1.69 | .093 | 1/2 |
| 4-4 T2H2BZ | 4TUBC4 | 400-R1-4 | 1/4 | 2.20 | 1.31 | 1.02 | .63 | 1.91 | .187 | 5/8 |
| 6-6 TH2HBZ | 6TUBC6 | 600-R1-6 | 3/8 | 2.42 | 1.44 | 1.16 | .69 | 2.13 | .281 | 3/4 |
| 8-8 T2H2BZ | 8TUBC8 | 810-R1-8 | 1/2 | 2.87 | 1.65 | 1.25 | .91 | 2.47 | .406 | 15/16 |

NOTE: A and C dimensions are typical finger-tight.

Dimensions for reference only, subject to change.

Tube stub is pre-grooved as standard. Generic (non-grooved) can be ordered through Quick Response Department.
Add -Z6 for assembly of nuts and ferrules on the tube stub end.

Port Connector For fractional tube

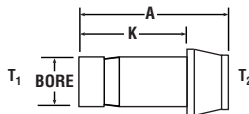

| CPI™ PART NO. | A-LOK® PART NO. | INTER- CHANGES WITH | INCHES | | | |
|------------------|--------------------|---------------------------|--------------|------|------|------|
| | | | TUBE O.D. | A | K | BORE |
| 1-1 ZPC | 1PC1 | 101-PC | 1/16 | 0.63 | 0.44 | .031 |
| 1-2 ZPC | 1PC2 | 201-PC-1 | 1/16-1/8 | 0.84 | 0.44 | .031 |
| 1-4 ZPC | 1PC4 | 401-PC-1 | 1/16-1/4 | 0.91 | 0.44 | .031 |
| 2-2 ZPC | 2PC2 | 201-PC | 1/8 | 0.95 | 0.54 | .078 |
| 2-4 ZPC | 2PC4 | 401-PC-2 | 1/8-1/4 | 1.05 | 0.54 | .078 |
| 2-6 ZPC | 2PC6 | 601-PC-2 | 1/8-3/8 | 1.09 | 0.54 | .031 |
| 3-3 ZPC | 3PC3 | 301-PC | 3/16 | 0.98 | 0.67 | .116 |
| 4-4 ZPC | 4PC4 | 401-PC | 1/4 | 1.07 | 0.76 | .156 |
| 4-6 ZPC | 4PC6 | 601-PC-4 | 1/4-3/8 | 1.15 | 0.64 | .156 |
| 4-8 ZPC | 4PC8 | 811-PC-4 | 1/4-1/2 | 1.36 | 0.64 | .156 |
| 6-6 ZPC | 6PC6 | 601-PC | 3/8 | 1.16 | 0.84 | .281 |
| 6-8 ZPC | 6PC8 | 811-PC-6 | 3/8-1/2 | 1.40 | 0.72 | .281 |
| 8-8 ZPC | 8PC8 | 811-PC | 1/2 | 1.59 | 1.11 | .375 |
| 8-12 ZPC | 8PC12 | 1211-PC-8 | 1/2-3/4 | 1.72 | 0.91 | .375 |
| 12-12 ZPC | 12PC12 | 1211-PC | 3/4 | 1.65 | 1.16 | .578 |
| 16-16 ZPC | 16PC16 | 1611-PC | 1 | 2.12 | 1.44 | .813 |

Dimensions for reference only, subject to change.

NOTE: Tube stub is pre-grooved as standard. (Size 1, 2, and 3 not grooved). Generic (non-grooved 4-16) can be ordered through Quick Response Department.

The machined ferrule end (T₂) requires only 1/4 turn from finger tight to assemble.
Add -Z6 for assembly of nuts and ferrules on the tube stub end.

Port Connector For metric tube

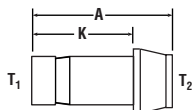

| CPI™ PART NO. | A-LOK® PART NO. | INTER- CHANGES WITH | MILLIMETERS | | | | |
|------------------|--------------------|---------------------------|----------------|----------------|------|------|------|
| | | | TUBE O.D. | | A | K | BORE |
| | | | T ₁ | T ₂ | | | |
| ZPC 3-3 | PCM3 | 3M1-PC | 3 | 3 | 22,2 | 15,7 | 1,6 |
| ZPC 6-6 | PCM6 | 6M1-PC | 6 | 6 | 24,6 | 18,7 | 3,0 |
| ZPC 8-8 | PCM8 | 8M1-PC | 8 | 8 | 25,9 | 20,0 | 5,0 |
| ZPC 10-10 | PCM10 | 10M1-PC | 10 | 10 | 26,1 | 20,2 | 6,0 |
| ZPC 12-12 | PCM12 | 12M1-PC | 12 | 12 | 35,8 | 26,0 | 8,0 |
| ZPC 16-16 | PCM16 | 16M1-PC | 16 | 16 | 40,5 | 27,7 | 12,0 |
| ZPC 18-18 | PCM18 | 18M1-PC | 18 | 18 | 40,8 | 27,7 | 13,0 |
| ZPC 3-6 | M3PCM6 | 6M1-PC-3M | 3 | 6 | 22,6 | 13,5 | 1,6 |
| ZPC 6-8 | M6PCM8 | 8M1-PC-6M | 6 | 8 | 25,5 | 16,1 | 3,0 |
| ZPC 6-10 | M6PCM10 | 10M1-PC-6M | 6 | 10 | 25,5 | 16,1 | 3,0 |
| ZPC 6-12 | M6PCM12 | 12M1-PC-6M | 6 | 12 | 31,2 | 16,1 | 3,0 |
| ZPC 8-10 | M8PCM10 | 10M1-PC-8M | 8 | 10 | 29,5 | 16,8 | 5,0 |
| ZPC 8-12 | M8PCM12 | 12M1-PC-8M | 8 | 12 | 31,4 | 16,8 | 5,0 |

Dimensions for reference only, subject to change.

NOTE: Tube stub is pre-grooved as standard. (Size M2, M3, and M4 not grooved).

The machined ferrule end (T₂) requires only 1/4 turn from finger tight to assemble.
Add -Z6 for assembly of nuts and ferrules on the tube stub end.

NPT Tube End Male Adapter For fractional tube

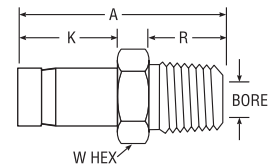
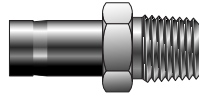

| CPI™ PART NO. | A-LOK® PART NO. | INTER- CHANGES WITH | INCHES | | | | | | |
|------------------|--------------------|---------------------------|--------------|--------------------|------|------|------|----------|-------|
| | | | TUBE O.D. | NPT PIPE THREAD | A | R | K | W HEX | BORE |
| 1-2 T2HF | 1MA2N | 1-TA-1-1 | 1/16 | 1/8 | 1.00 | 0.38 | 0.38 | 7/16 | .031 |
| 2-2 T2HF | 2MA2N | 2-TA-1-2 | 1/8 | 1/8 | 1.16 | 0.38 | 0.54 | 7/16 | .078 |
| 2-4 T2HF | 2MA4N | 2-TA-1-4 | 1/8 | 1/4 | 1.38 | 0.56 | 0.54 | 9/16 | .078 |
| 3-2 T2HF | 3MA2N | 3-TA-1-2 | 3/16 | 1/8 | 1.20 | 0.38 | 0.58 | 7/16 | .116 |
| 3-4 T2HF | 3MA4N | 3-TA-1-4 | 3/16 | 1/4 | 1.42 | 0.56 | 0.58 | 9/16 | .116 |
| 4-2 T2HF | 4MA2N | 4-TA-1-2 | 1/4 | 1/8 | 1.25 | 0.38 | 0.63 | 7/16 | .156 |
| 4-4 T2HF | 4MA4N | 4-TA-1-4 | 1/4 | 1/4 | 1.46 | 0.56 | 0.63 | 9/16 | .156 |
| 4-6 T2HF | 4MA6N | 4-TA-1-6 | 1/4 | 3/8 | 1.49 | 0.56 | 0.63 | 11/16 | .156 |
| 4-8 T2HF | 4MA8N | 4-TA-1-8 | 1/4 | 1/2 | 1.71 | 0.75 | 0.63 | 7/8 | .156 |
| 5-2 T2HF | 5MA2N | 5-TA-1-2 | 5/16 | 1/8 | 1.29 | 0.38 | 0.66 | 7/16 | .219 |
| 5-4 T2HF | 5MA4N | 5-TA-1-4 | 5/16 | 1/4 | 1.50 | 0.56 | 0.66 | 9/16 | .219 |
| 5-6 T2HF | 5MA6N | 5-TA-1-6 | 5/16 | 3/8 | 1.53 | 0.56 | 0.66 | 11/16 | .219 |
| 5-8 T2HF | 5MA8N | 5-TA-1-8 | 5/16 | 1/2 | 1.74 | 0.75 | 0.66 | 7/8 | .219 |
| 6-2 T2HF | 6MA2N | 6-TA-1-2 | 3/8 | 1/8 | 1.32 | 0.38 | 0.69 | 7/16 | .281 |
| 6-4 T2HF | 6MA4N | 6-TA-1-4 | 3/8 | 1/4 | 1.53 | 0.56 | 0.69 | 9/16 | .281 |
| 6-6 T2HF | 6MA6N | 6-TA-1-6 | 3/8 | 3/8 | 1.56 | 0.56 | 0.69 | 11/16 | .281 |
| 6-8 T2HF | 6MA8N | 6-TA-1-8 | 3/8 | 1/2 | 1.78 | 0.75 | 0.69 | 7/8 | .281 |
| 8-4 T2HF | 8MA4N | 8-TA-1-4 | 1/2 | 1/4 | 1.75 | 0.56 | 0.91 | 9/16 | .281 |
| 8-6 T2HF | 8MA6N | 8-TA-1-6 | 1/2 | 3/8 | 1.78 | 0.56 | 0.91 | 11/16 | .375 |
| 8-8 T2HF | 8MA8N | 8-TA-1-8 | 1/2 | 1/2 | 2.00 | 0.75 | 0.91 | 7/8 | .375 |
| 10-8 T2HF | 10MA8N | 10-TA-1-8 | 5/8 | 1/2 | 2.06 | 0.75 | 0.97 | 7/8 | .469 |
| 12-8 T2HF | 12MA8N | 12-TA-1-8 | 3/4 | 1/2 | 2.06 | 0.75 | 0.97 | 7/8 | .469 |
| 12-12 T2HF | 12MA12N | 12-TA-1-12 | 3/4 | 3/4 | 2.06 | 0.75 | 0.97 | 1-1/16 | .578 |
| 12-16 T2HF | 12MA16N | 12-TA-1-16 | 3/4 | 1 | 2.41 | 0.94 | 0.97 | 1-3/8 | .813 |
| 16-12 T2HF | 16MA12N | 16-TA-1-12 | 1 | 3/4 | 2.31 | 0.75 | 1.22 | 1-1/16 | .813 |
| 16-16 T2HF | 16MA16N | 16-TA-1-16 | 1 | 1 | 2.68 | 0.94 | 1.22 | 1-3/8 | .813 |
| 20-20 T2HF | 20MA20N | 20-TA-1-20 | 1-1/4 | 1-1/4 | 3.16 | 0.97 | 1.71 | 1-3/4 | 1.000 |
| 24-24 T2HF | 24MA24N | 24-TA-1-24 | 1-1/2 | 1-1/2 | 3.72 | 1.00 | 2.05 | 2-1/8 | 1.250 |
| 32-32 T2HF | 32MA32N | 32-TA-1-32 | 2 | 2 | 4.70 | 1.04 | 2.74 | 2-3/4 | 1.720 |

NOTE: Add -Z6 for assembly of nuts and ferrules on the tube stub end.

Dimensions for reference only, subject to change.

Tube stub is pre-grooved as standard. Generic (non-grooved) can be ordered through Quick Response Department.

Inch sizes 1, 2, and 3 and metric sizes 2, 3, and 4mm do not have grooves.

Sizes 20, 24, 32 require additional lubrication prior to assembly.

BSPP Tube End Male Adapter For fractional tube

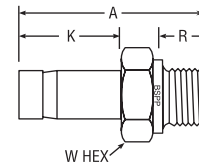
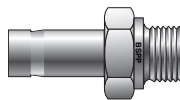

| CPI™ PART NO. | A-LOK® PART NO. | INTER- CHANGES WITH | INCHES | | | | | | |
|------------------|--------------------|---------------------------|--------------|----------------|------|------|-----|----------|------|
| | | | TUBE O.D. | BSPP THREAD | A | K | R | W HEX | BORE |
| 2-2R T2HF | 2MA2R | 2TA-1-2RS | 1/8 | 1/8 | 1.09 | 0.53 | .28 | 9/16 | .05 |
| 2-4R T2HF | 2MA4R | 2TA-1-4RS | 1/8 | 1/4 | 1.31 | 0.53 | .44 | 3/4 | .05 |
| 4-2R T2HF | 4MA2R | 4TA-1-2RS | 1/4 | 1/8 | 1.19 | 0.63 | .28 | 9/16 | .16 |
| 4-4R T2HF | 4MA4R | 4TA-1-4RS | 1/4 | 1/4 | 1.50 | 0.63 | .44 | 3/4 | .18 |
| 6-2R T2HF | 6MA2R | 6TA-1-2RS | 3/8 | 1/8 | 1.34 | 0.69 | .28 | 3/4 | .05 |
| 6-4R T2HF | 6MA4R | 6TA-1-4RS | 3/8 | 1/4 | 1.47 | 0.69 | .44 | 3/4 | .25 |
| 6-6R T2HF | 6MA6R | 6TA-1-6RS | 3/8 | 3/8 | 1.50 | 0.69 | .44 | 7/8 | .28 |
| 6-8R T2HF | 6MA8R | 6TA-1-8RS | 3/8 | 1/2 | 1.69 | 0.69 | .56 | 1-1/16 | .28 |
| 8-4R T2HF | 8MA4R | 8TA-1-4RS | 1/2 | 1/4 | 1.69 | 0.91 | .44 | 3/4 | .25 |
| 8-6R T2HF | 8MA6R | 8TA-1-6RS | 1/2 | 3/8 | 1.72 | 0.91 | .44 | 7/8 | .31 |
| 8-8R T2HF | 8MA8R | 8TA-1-8RS | 1/2 | 1/2 | 1.94 | 0.91 | .56 | 1-1/16 | .39 |
| 10-8R T2HF | 10MA8R | 10TA-1-8RS | 5/8 | 1/2 | 1.97 | 0.97 | .56 | 1-1/16 | .47 |
| 12-12R T2HF | 12MA12R | 12TA-1-12RS | 3/4 | 3/4 | 2.09 | 0.97 | .63 | 1-5/16 | .578 |
| 16-16R T2HF | 16MA16R | 16TA-1-16RS | 1 | 1 | 2.53 | 1.22 | .72 | 1-5/8 | .80 |

NOTE: Add -Z6 for assembly of nuts and ferrules on the tube stub end.

Dimensions for reference only, subject to change.

Tube stub is pre-grooved as standard. Generic (non-grooved) can be ordered through Quick Response Department.

Bonded sealing washer must be used with this design, see page 73..

BSPP Tube End Male Adapter For metric tube

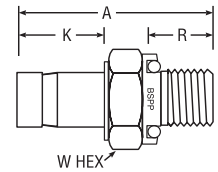

| CPI™ PART NO. | A-LOK® PART NO. | INTER- CHANGES WITH | MILLIMETERS | | | | | | | | |
|------------------|--------------------|---------------------------|---------------|----------------|------|------|-----|------|------|----------|------|
| | | | TUBE O. D. | BSPP THREAD | A | K | Q | R | X | W HEX | BORE |
| T2HF 3-1/8R | M3MA1/8R | 3-MTA-1-2RS | 3 | 1/8 | 31,0 | 13,5 | 0,6 | 7,1 | 13,7 | 14,0 | 1,8 |
| T2HF 4-1/8R | M4MA1/8R | 4-MTA-1-2RS | 4 | 1/8 | 31,8 | 14,3 | 1,0 | 7,1 | 13,7 | 14,0 | 2,0 |
| T2HF 6-1/8R | M6MA1/8R | 6-MTA-1-2RS | 6 | 1/8 | 33,3 | 15,9 | 1,0 | 7,1 | 13,7 | 14,0 | 4,0 |
| T2HF 6-1/4R | M6MA1/4R | 6-MTA-1-4RS | 6 | 1/4 | 38,1 | 15,9 | 1,0 | 11,2 | 17,8 | 19,0 | 4,0 |
| T2HF 8-1/4R | M8MA1/4R | 8-MTA-1-4RS | 8 | 1/4 | 38,9 | 16,7 | 0,8 | 11,2 | 17,8 | 19,0 | 6,4 |
| T2HF 10-1/4R | M10MA1/4R | 10-MTA-1-4RS | 10 | 1/4 | 39,7 | 17,5 | 1,3 | 11,2 | 17,8 | 19,0 | 6,4 |
| T2HF 10-3/8R | M10MA3/8R | 10-MTA-1-6RS | 10 | 3/8 | 38,9 | 17,5 | 1,3 | 11,2 | 21,8 | 22,0 | 7,5 |
| T2HF 10-1/2R | M10MA1/2R | 10-MTA-1-8RS | 10 | 1/2 | 42,9 | 17,5 | 1,3 | 14,2 | 25,7 | 27,0 | 7,5 |
| T2HF 12-1/4R | M12MA1/4R | 12-MTA-1-4RS | 12 | 1/4 | 43,7 | 23,0 | 1,4 | 11,2 | 17,8 | 19,0 | 6,4 |
| T2HF 12-3/8R | M12MA3/8R | 12-MTA-1-6RS | 12 | 3/8 | 44,5 | 23,0 | 1,4 | 11,2 | 21,8 | 22,0 | 7,9 |
| T2HF 12-1/2R | M12MA1/2R | 12-MTA-1-8RS | 12 | 1/2 | 49,2 | 23,0 | 1,4 | 14,2 | 25,7 | 27,0 | 9,1 |
| T2HF 16-1/2R | M16MA1/2R | 16-MTA-1-8RS | 16 | 1/2 | 50,8 | 24,6 | 1,7 | 14,2 | 25,7 | 27,0 | 11,9 |
| T2HF 18-3/4R | M18MA3/4R | 18-MTA-1-12RS | 18 | 3/4 | 53,2 | 24,6 | 2,0 | 16,0 | 31,8 | 33,0 | 14,0 |
| T2HF 20-3/4R | M20MA3/4R | 20-MTA-1-12RS | 20 | 3/4 | 54,0 | 25,4 | 2,5 | 16,0 | 31,8 | 33,0 | 15,1 |
| T2HF 25-1R | M25MA1R | 25-MTA-1-16RS | 25 | 1 | 65,1 | 31,8 | 2,6 | 18,3 | 38,6 | 41,0 | 19,8 |

Dimensions for reference only, subject to change.

NOTE: Tube stub is pre-grooved as standard. Generic (non-grooved) can be ordered through Quick Response Department.

Bonded sealing washer must be used with this design, see page 73.
Add -Z6 for assembly of nuts and ferrules on the tube stub end.

BSPP Tube End Male Adapter with ED Seal For fractional tube

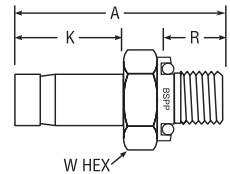
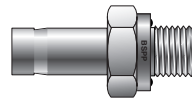

| CPI™ PART NO. | A-LOK® PART NO. | INTER- CHANGES WITH | INCHES | | | | | | | |
|------------------|--------------------|---------------------------|---------------|----------------|------|-----|-----|------|----------|------|
| | | | TUBE O. D. | BSPP THREAD | A | K | R | X | W HEX | BORE |
| 4-4R-ED T2HF | 4MA4R-ED | - | 1/4 | 1/4 | 1.50 | .63 | .47 | 0.74 | 3/4 | .18 |
| 4-6R-ED T2HF | 4MA6R-ED | - | 1/4 | 3/8 | 1.50 | .63 | .47 | 0.86 | 3/4 | .18 |
| 8-4R-ED T2HF | 8MA4R-ED | - | 1/2 | 1/4 | 1.75 | .91 | .47 | 0.74 | 3/4 | .25 |
| 8-6R-ED T2HF | 8MA6R-ED | - | 1/2 | 3/8 | 1.78 | .91 | .47 | 0.86 | 7/8 | .31 |
| 8-8R-ED T2HF | 8MA8R-ED | - | 1/2 | 1/2 | 1.94 | .91 | .55 | 1.04 | 1-1/16 | .39 |

Dimensions for reference only, subject to change.

NOTE: Tube stub is pre-grooved as standard. Generic (non-grooved) can be ordered through Quick Response Department.

ED fittings are supplied with sealing washers in nitrile as standard, suitable for temperatures between -35°C and +100°C (-31°F to +212°F). Fluorocarbon seals are available upon request which are suitable for temperatures between -25°C and +120°C (-13°F to +248°F).
Add -Z6 for assembly of nuts and ferrules on the tube stub end.

Color Coding

For easy reference, table column headings are color indicated as follows:

fractional



metric



BSPP Tube End Male Adapter with ED Seal

For metric tube

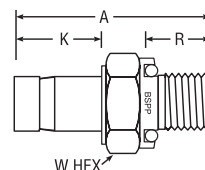
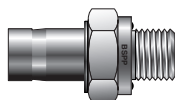

| CPI™ PART NO. | A-LOK® PART NO. | INTER- CHANGES WITH | MILLIMETERS | | | | | | |
|------------------|--------------------|---------------------------|---------------|----------------|------|------|------|----------|------|
| | | | TUBE O. D. | BSPP THREAD | A | K | R | W HEX | BORE |
| T2HF 6-1/4R-ED | M6MA1/4R-ED | – | 6 | 1/4 | 36,6 | 15,9 | 7,9 | 19,0 | 4,0 |
| T2HF 6-1/2R-ED | M6MA1/2R-ED | – | 6 | 1/2 | 42,7 | 15,9 | 14,0 | 27,0 | 4,0 |
| T2HF 10-1/4R-ED | M10MA1/4R-ED | – | 10 | 1/4 | 38,1 | 17,5 | 11,9 | 19,0 | 6,4 |
| T2HF 10-1/2R-ED | M10MA1/2R-ED | – | 10 | 1/2 | 44,2 | 17,5 | 14,0 | 27,0 | 7,5 |
| T2HF 12-1/4R-ED | M12MA1/4R-ED | – | 12 | 1/4 | 43,7 | 23,0 | 11,9 | 19,0 | 6,4 |
| T2HF 12-3/8R-ED | M12MA3/8R-ED | – | 12 | 3/8 | 45,0 | 23,0 | 11,9 | 22,0 | 7,9 |
| T2HF 12-1/2R-ED | M12MA1/2R-ED | – | 12 | 1/2 | 49,8 | 23,0 | 14,0 | 27,0 | 9,1 |

Dimensions for reference only, subject to change.

NOTE: Tube stub is pre-grooved as standard. Generic (non-grooved) can be ordered through Quick Response Department.

ED fittings are supplied with sealing washers in nitrile as standard, suitable for temperatures between -35°C and +100°C (-31°F to +212°F). Fluorocarbon seals are available upon request which are suitable for temperatures between -25°C and +120°C (-13°F to +248°F). Add -Z6 for assembly of nuts and ferrules on the tube stub end.

NPT Male Adapter

For metric tube

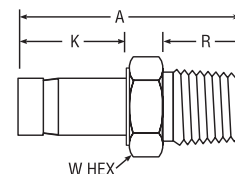
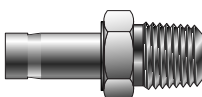

| CPI™ PART NO. | A-LOK® PART NO. | INTER- CHANGES WITH | MILLIMETERS | | | | | | |
|------------------|--------------------|---------------------------|---------------|---------------|------|------|------|----------|------|
| | | | TUBE O. D. | NPT THREAD | A | K | R | W HEX | BORE |
| T2HF 3-1/8 | M3MA1/8N | 3-MTA-1-2 | 3 | 1/8 | 29,4 | 13,5 | 9,7 | 12,0 | 1,8 |
| T2HF 4-1/8 | M4MA1/8N | 4-MTA-1-2 | 4 | 1/8 | 29,4 | 14,3 | 9,7 | 12,0 | 2,0 |
| T2HF 6-1/8 | M6MA1/8N | 6-MTA-1-2 | 6 | 1/8 | 31,0 | 15,9 | 9,7 | 12,0 | 4,0 |
| T2HF 6-1/4 | M6MA1/4N | 6-MTA-1-4 | 6 | 1/4 | 35,7 | 15,9 | 14,2 | 14,0 | 4,0 |
| T2HF 6-3/8 | M6MA3/8N | 6-MTA-1-6 | 6 | 3/8 | 36,5 | 16,1 | 14,2 | 18,0 | 3,0 |
| T2HF 6-1/2 | M6MA1/2N | 6-MTA-1-8 | 6 | 1/2 | 42,1 | 16,1 | 19,1 | 22,0 | 3,0 |
| T2HF 8-1/4 | M8MA1/4N | 8-MTA-1-4 | 8 | 1/4 | 37,3 | 16,7 | 14,2 | 14,0 | 6,4 |
| T2HF 8-3/8 | M8MA3/8N | 8-MTA-1-6 | 8 | 3/8 | 38,1 | 16,7 | 14,2 | 12,0 | 6,4 |
| T2HF 10-1/4 | M10MA1/4N | 10-MTA-1-4 | 10 | 1/4 | 38,1 | 17,5 | 14,2 | 14,0 | 7,1 |
| T2HF 10-3/8 | M10MA3/8N | 10-MTA-1-6 | 10 | 3/8 | 43,7 | 17,5 | 14,2 | 18,0 | 7,5 |
| T2HF 10-1/2 | M10MA1/2N | 10-MTA-1-8 | 10 | 1/2 | 44,5 | 17,5 | 19,1 | 22,0 | 7,5 |
| T2HF 12-1/4 | M12MA1/4N | 12-MTA-1-4 | 12 | 1/4 | 43,7 | 23,0 | 14,2 | 14,0 | 7,1 |
| T2HF 12-3/8 | M12MA3/8N | 12-MTA-1-6 | 12 | 3/8 | 44,5 | 23,0 | 14,2 | 27,0 | 9,1 |
| T2HF 12-1/2 | M12MA1/2N | 12-MTA-1-8 | 12 | 1/2 | 49,2 | 23,0 | 19,1 | 22,0 | 9,1 |
| T2HF 16-1/2 | M16MA1/2N | 16-MTA-1-8 | 16 | 1/2 | 50,8 | 24,6 | 19,1 | 22,0 | 12,7 |
| T2HF 16-3/4 | M16MA3/4N | 16-MTA-1-12 | 16 | 3/4 | 51,6 | 24,6 | 19,1 | 27,0 | 12,7 |
| T2HF 18-1/2 | M18MA1/2N | 18-MTA-1-8 | 18 | 1/2 | 50,8 | 24,6 | 19,1 | 22,0 | 12,7 |
| T2HF 18-3/4 | M18MA3/4N | 18-MTA-1-12 | 18 | 3/4 | 51,6 | 24,6 | 19,1 | 27,0 | 14,0 |
| T2HF 20-1/2 | M20MA1/2N | 20-MTA-1-8 | 20 | 1/2 | 51,8 | 25,6 | 19,1 | 22,0 | 15,0 |
| T2HF 20-3/4 | M20MA3/4N | 20-MTA-1-12 | 20 | 3/4 | 52,4 | 25,4 | 19,1 | 27,0 | 15,1 |
| T2HF 25-1 | M25MA1N | 25-MTA-1-16 | 25 | 1 | 65,9 | 31,8 | 23,9 | 35,0 | 19,8 |

Dimensions for reference only, subject to change.

NOTE: Tube stub is pre-grooved as standard. Generic (non-grooved) can be ordered through Quick Response Department.

Add -Z6 for assembly of nuts and ferrules on the tube stub end.

Color Coding

For easy reference, table column headings are color indicated as follows:

fractional



metric



BSP Taper Male Adapter For fractional tube

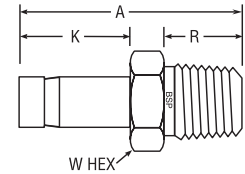
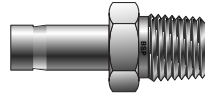

| CPI™ PART NO. | A-LOK® PART NO. | INTER- CHANGES WITH | INCHES | | | | | | |
|------------------|--------------------|---------------------------|--------------|----------------|------|-----|-----|----------|------|
| | | | TUBE O.D. | BSPT THREAD | A | K | R | W HEX | BORE |
| 4-2K T2HFK | 4MA2K | 4-TA-1-2RT | 1/4 | 1/8 | 1.25 | .63 | .38 | 7/16 | .156 |
| 4-4K T2HFK | 4MA4K | 4-TA-1-4RT | 1/4 | 1/4 | 1.46 | .63 | .56 | 9/16 | .156 |
| 4-6K T2HFK | 4MA6K | 4-TA-1-6RT | 1/4 | 3/8 | 1.44 | .63 | .56 | 11/16 | .156 |
| 4-8K T2HFK | 4MA8K | 4-TA-1-8RT | 1/4 | 1/2 | 1.66 | .63 | .75 | 7/8 | .219 |
| 5-2 T2HFK | 5MA2K | 5-TA-1-2RT | 5/16 | 1/8 | 1.29 | .66 | .38 | 7/16 | .219 |
| 5-4 T2HFK | 5MA4K | 5-TA-1-4RT | 5/16 | 1/4 | 1.50 | .66 | .56 | 9/16 | .219 |
| 6-4 T2HFK | 6MA4K | 6-TA-1-4RT | 3/8 | 1/4 | 1.50 | .69 | .56 | 9/16 | .281 |
| 6-6 T2HFK | 6MA6K | 6-TA-1-6RT | 3/8 | 3/8 | 1.50 | .69 | .56 | 11/16 | .281 |
| 6-8 T2HFK | 6MA8K | 6-TA-1-8RT | 3/8 | 1/2 | 1.72 | .69 | .75 | 7/8 | .281 |
| 8-4 T2HFK | 8MA4K | 8-TA-1-4RT | 1/2 | 1/4 | 1.72 | .91 | .56 | 9/16 | .375 |
| 8-6 T2HFK | 8MA6K | 8-TA-1-6RT | 1/2 | 3/8 | 1.75 | .91 | .56 | 11/16 | .375 |
| 8-8 T2HFK | 8MA8K | 8-TA-1-8RT | 1/2 | 1/2 | 1.94 | .91 | .75 | 7/8 | .375 |
| 10-8 T2HFK | 10MA8K | 10-TA-1-8RT | 5/8 | 1/2 | 2.06 | .97 | .75 | 7/8 | .469 |

Dimensions for reference only, subject to change.

NOTE: Tube stub is pre-grooved as standard. Generic (non-grooved) can be ordered through Quick Response Department.

Add -Z6 for assembly of nuts and ferrules on the tube stub end.

BSP Taper Male Adapter For metric tube

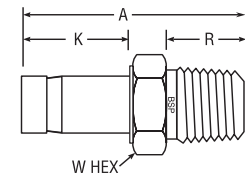
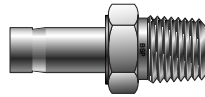

| CPI™ PART NO. | A-LOK® PART NO. | INTER- CHANGES WITH | MILLIMETERS | | | | | | |
|------------------|--------------------|---------------------------|--------------|----------------|------|------|------|----------|------|
| | | | TUBE O.D. | BSPT THREAD | A | K | R | W HEX | BORE |
| T2HF 3-1/8K | M3MA1/8K | 3-MTA-1-2RT | 3 | 1/8 | 29,4 | 13,5 | 9,7 | 12,0 | 1,8 |
| T2HF 4-1/8K | M4MA1/8K | 4-MTA-1-2RT | 4 | 1/8 | 29,4 | 14,3 | 9,7 | 12,0 | 2,0 |
| T2HF 6-1/8K | M6MA1/8K | 6-MTA-1-2RT | 6 | 1/8 | 31,0 | 15,9 | 9,7 | 12,0 | 4,0 |
| T2HF 6-1/4K | M6MA1/4K | 6-MTA-1-4RT | 6 | 1/4 | 35,7 | 15,9 | 14,2 | 14,0 | 4,0 |
| T2HF 8-1/4K | M8MA1/4K | 8-MTA-1-4RT | 8 | 1/4 | 37,3 | 16,7 | 14,2 | 14,0 | 6,4 |
| T2HF 8-3/8K | M8MA3/8K | 8-MTA-1-6RT | 8 | 3/8 | 38,3 | 16,8 | 14,2 | 18,0 | 5,0 |
| T2HF 10-1/4K | M10MA1/4K | 10-MTA-1-4RT | 10 | 1/4 | 38,1 | 17,5 | 14,2 | 14,0 | 7,1 |
| T2HF 10-3/8K | M10MA3/8K | 10-MTA-1-6RT | 10 | 3/8 | 38,1 | 17,5 | 14,2 | 18,0 | 7,5 |
| T2HF 10-1/2K | M10MA1/2K | 10-MTA-1-8RT | 10 | 1/2 | 44,5 | 17,5 | 19,1 | 22,0 | 7,5 |
| T2HF 12-1/4K | M12MA1/4K | 12-MTA-1-4RT | 12 | 1/4 | 43,7 | 23,0 | 14,2 | 14,0 | 7,1 |
| T2HF 12-3/8K | M12MA3/8K | 12-MTA-1-6RT | 12 | 3/8 | 44,5 | 23,0 | 14,2 | 18,0 | 9,1 |
| T2HF 12-1/2K | M12MA1/2K | 12-MTA-1-8RT | 12 | 1/2 | 49,2 | 23,0 | 19,1 | 22,0 | 9,1 |
| T2HF 16-1/2K | M16MA1/2K | 16-MTA-1-8RT | 16 | 1/2 | 50,8 | 24,6 | 19,1 | 22,0 | 12,7 |
| T2HF 18-3/4K | M18MA3/4K | 18-MTA-1-12RT | 18 | 3/4 | 51,6 | 24,6 | 19,1 | 27,0 | 14,0 |
| T2HF 20-3/4K | M20MA3/4K | 20-MTA-1-12RT | 20 | 3/4 | 52,4 | 25,4 | 19,1 | 27,0 | 15,1 |
| T2H 25-1K | M25MA1K | 25-MTA-1-16RT | 25 | 1 | 65,9 | 31,8 | 23,9 | 35,0 | 19,8 |

Dimensions for reference only, subject to change.

NOTE: Tube stub is pre-grooved as standard. Generic (non-grooved) can be ordered through Quick Response Department.

Add -Z6 for assembly of nuts and ferrules on the tube stub end.

Tube End to SAE Straight Thread Adapter For fractional tube

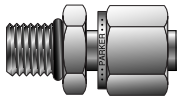
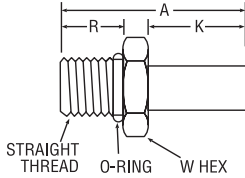
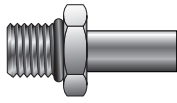

| CPT™ PART NO. | A-LOK® PART NO. | INTER- CHANGES WITH | INCHES | | | | | | O-RING APR UNIFORM DASH NO. |
|------------------|--------------------|---------------------------|-------------------|----------------------------|------|------|-----|----------|--------------------------------------|
| | | | T TUBE O.D. | STRAIGHT THREAD SIZE | A | K | R | W HEX | |
| 6-4 T2HOA | 6TUHOA4 | 6-TA-1-4ST | 3/8 | 7/16-20 | 1.46 | 0.69 | .36 | 9/16 | 3-904 |
| 6-8 T2HOA | 6TUHOA8 | 6-TA-1-8ST | 3/8 | 3/4-16 | 1.59 | 0.69 | .44 | 7/8 | 3-908 |
| 8-6 T2HOA | 8TUHOA6 | 8-TA-1-6ST | 1/2 | 9/16-18 | 1.74 | 0.91 | .39 | 11/16 | 3-906 |
| 10-10 T2HOA | 10TUHOA10 | 10-TA-1-10ST | 5/8 | 7/8-14 | 1.94 | 0.91 | .50 | 1 | 3-910 |
| *24-24 T2HOA | 24TUHOA24 | 24-TA-1-24ST | 1-1/2 | 1-7/8-12 | 3.28 | 2.05 | .59 | 2-1/8 | 3-924 |

* Size 24 is preassembled with nut and ferrules.

Dimensions for reference only, subject to change.

A dimension is typical finger-tight.

Size 24 requires additional lubrication prior to assembly.

Parts are supplied with nitrile o-rings as standard. For Fluorocarbon o-rings, add the suffix "-VO".

Other o-rings available upon request.

Add -Z6 for assembly of nuts and ferrules
on the tube stub end.

Tube End NPT Female Adapter For fractional tube

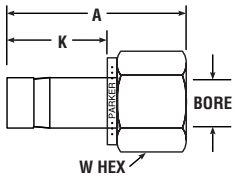
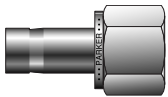

| CPT™ PART NO. | A-LOK® PART NO. | INTER- CHANGES WITH | INCHES | | | | | |
|------------------|--------------------|---------------------------|--------------|--------------------|------|------|----------|-------|
| | | | TUBE O.D. | NPT PIPE THREAD | A | K | W HEX | BORE |
| 1-2 T2HG | 1FA2N | 1-TA-7-2 | 1/16 | 1/8 | 1.07 | 0.34 | 9/16 | .031 |
| 2-2 T2HG | 2FA2N | 2-TA-7-2 | 1/8 | 1/8 | 1.23 | 0.53 | 9/16 | .093 |
| 2-4 T2HG | 2FA4N | 2-TA-7-4 | 1/8 | 1/4 | 1.38 | 0.53 | 3/4 | .093 |
| 3-2 T2HG | 3FA2N | 3-TA-7-2 | 3/16 | 1/8 | 1.25 | 0.56 | 9/16 | .116 |
| 3-4 T2HG | 3FA4N | 3-TA-7-4 | 3/16 | 1/4 | 1.42 | 0.56 | 3/4 | .116 |
| 4-2 T2HG | 4FA2N | 4-TA-7-2 | 1/4 | 1/8 | 1.31 | 0.63 | 9/16 | .188 |
| 4-4 T2HG | 4FA4N | 4-TA-7-4 | 1/4 | 1/4 | 1.47 | 0.63 | 3/4 | .188 |
| 4-6 T2HG | 4FA6N | 4-TA-7-6 | 1/4 | 3/8 | 1.56 | 0.63 | 7/8 | .188 |
| 4-8 T2HG | 4FA8N | 4-TA-7-8 | 1/4 | 1/2 | 1.80 | 0.63 | 1-1/16 | .188 |
| 5-2 T2HG | 5FA2N | 5-TA-7-2 | 5/16 | 1/8 | 1.34 | 0.66 | 9/16 | .219 |
| 5-4 T2HG | 5FA4N | 5-TA-7-4 | 5/16 | 1/4 | 1.50 | 0.66 | 3/4 | .219 |
| 5-6 T2HG | 5FA6N | 5-TA-7-6 | 5/16 | 3/8 | 1.59 | 0.66 | 7/8 | .219 |
| 6-2 T2HG | 6FA2N | 6-TA-7-2 | 3/8 | 1/8 | 1.36 | 0.69 | 9/16 | .281 |
| 6-4 T2HG | 6FA4N | 6-TA-7-4 | 3/8 | 1/4 | 1.55 | 0.69 | 3/4 | .281 |
| 6-6 T2HG | 6FA6N | 6-TA-7-6 | 3/8 | 3/8 | 1.59 | 0.69 | 7/8 | .281 |
| 6-8 T2HG | 6FA8N | 6-TA-7-8 | 3/8 | 1/2 | 1.84 | 0.69 | 1-1/16 | .281 |
| 8-4 T2HG | 8FA4N | 8-TA-7-4 | 1/2 | 1/4 | 1.72 | 0.91 | 3/4 | .391 |
| 8-6 T2HG | 8FA6N | 8-TA-7-6 | 1/2 | 3/8 | 1.80 | 0.91 | 7/8 | .391 |
| 8-8 T2HG | 8FA8N | 8-TA-7-8 | 1/2 | 1/2 | 2.10 | 0.91 | 1-1/16 | .390 |
| 10-6 T2HG | 10FA6N | 10-TA-7-6 | 5/8 | 3/8 | 1.86 | 0.97 | 7/8 | .469 |
| 10-8 T2HG | 10FA8N | 10-TA-7-8 | 5/8 | 1/2 | 2.09 | 0.97 | 1-1/16 | .469 |
| 12-8 T2HG | 12FA8N | 12-TA-7-8 | 3/4 | 1/2 | 2.10 | 0.97 | 1-1/16 | .578 |
| 12-12 T2HG | 12FA12N | 12-TA-7-12 | 3/4 | 3/4 | 2.16 | 0.97 | 1-1/4 | .578 |
| 12-16 T2HG | 12FA16N | 12-TA-7-16 | 3/4 | 1 | 2.30 | 0.97 | 1-5/8 | .578 |
| 14-12 T2HG | 14FA12N | 14-TA-7-12 | 7/8 | 3/4 | 2.22 | 1.02 | 1-5/16 | .578 |
| 16-12 T2HG | 16FA12N | 16-TA-7-12 | 1 | 3/4 | 2.41 | 1.22 | 1-5/16 | .813 |
| 16-16 T2HG | 16FA16N | 16-TA-7-16 | 1 | 1 | 2.54 | 1.22 | 1-5/8 | .813 |
| 20-20 T2HG | 20FA20N | 20-TA-7-20 | 1-1/4 | 1-1/4 | 3.06 | 1.71 | 2-1/8 | 1.000 |
| 24-24 T2HG | 24FA24N | 24-TA-7-24 | 1-1/2 | 1-1/2 | 3.50 | 2.05 | 2-3/8 | 1.250 |
| 32-32 T2HG | 32FA32N | 32-TA-7-32 | 2 | 2 | 4.23 | 2.74 | 2-7/8 | 1.720 |

NOTE: Tube stub is pre-grooved as standard.

Dimensions for reference only, subject to change.

Generic (non-grooved) can be ordered through Quick Response Department.

Add -Z6 for assembly of nuts and ferrules on the tube stub end.

Color Coding

For easy reference, table column headings are color indicated as follows:

fractional



metric



Tube End NPT Female Adapter For metric tube

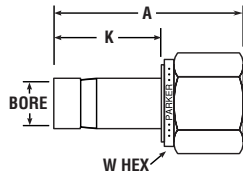
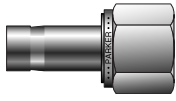

| CPI™ PART NO. | A-LOK® PART NO. | INTER- CHANGES WITH | MILLIMETERS | | | | | |
|------------------|--------------------|---------------------------|---------------|---------------|------|------|----------|------|
| | | | TUBE O. D. | NPT THREAD | A | K | W HEX | BORE |
| T2HG 3-1/8 | M3FA1/8N | 3-MTA-7-2 | 3 | 1/8 | 31,3 | 13,5 | 14,0 | 1,3 |
| T2HG 4-1/8 | M4FA1/8N | 4-MTA-7-2 | 4 | 1/8 | 29,4 | 14,3 | 14,0 | 2,0 |
| T2HG 6-1/8 | M6FA1/8N | 6-MTA-7-2 | 6 | 1/8 | 29,4 | 15,9 | 14,0 | 4,0 |
| T2HG 6-1/4 | M6FA1/4N | 6-MTA-7-4 | 6 | 1/4 | 34,1 | 15,9 | 19,0 | 4,0 |
| T2HG 8-1/8 | M8FA1/8N | 8-MTA-7-2 | 8 | 1/8 | 35,5 | 16,7 | 14,0 | 6,4 |
| T2HG 8-1/4 | M8FA1/4N | 8-MTA-7-4 | 8 | 1/4 | 35,1 | 16,7 | 19,0 | 6,4 |
| T2HG 8-3/8 | M8FA3/8N | 8-MTA-7-6 | 8 | 3/8 | 36,5 | 16,7 | 22,0 | 6,4 |
| T2HG 10-1/4 | M10FA1/4N | 10-MTA-7-4 | 10 | 1/4 | 37,3 | 17,5 | 19,0 | 7,5 |
| T2HG 10-3/8 | M10FA3/8N | 10-MTA-7-6 | 10 | 3/8 | 37,3 | 17,5 | 22,0 | 7,5 |
| T2HG 10-1/2 | M10FA1/2N | 10-MTA-7-8 | 10 | 1/2 | 42,1 | 17,5 | 27,0 | 7,5 |
| T2HG 12-1/4 | M12FA1/4N | 12-MTA-7-4 | 12 | 1/4 | 41,3 | 23,0 | 19,0 | 9,1 |
| T2HG 12-3/8 | M12FA3/8N | 12-MTA-7-6 | 12 | 3/8 | 42,9 | 23,0 | 22,0 | 9,1 |
| T2HG 12-1/2 | M12FA1/2N | 12-MTA-7-8 | 12 | 1/2 | 47,6 | 23,0 | 27,0 | 9,1 |
| T2HG 16-1/2 | M16FA1/2N | 16-MTA-7-8 | 16 | 1/2 | 49,2 | 24,6 | 27,0 | 12,7 |
| T2HG 18-3/4 | M18FA3/4N | 18-MTA-7-12 | 18 | 3/4 | 52,4 | 24,6 | 33,0 | 14,0 |
| T2HG 20-1/2 | M20FA1/2N | 20-MTA-7-8 | 20 | 1/2 | 50,0 | 25,6 | 27,0 | 15,0 |
| T2HG 20-3/4 | M20FA3/4N | 20-MTA-7-12 | 20 | 3/4 | 53,2 | 25,4 | 33,0 | 15,1 |
| T2G 25-1 | M25FA1N | 25-MTA-7-16 | 25 | 1 | 66,7 | 31,8 | 41,0 | 19,8 |

NOTE: Tube stub is pre-grooved as standard.

Dimensions for reference only, subject to change.

Generic (non-grooved) can be ordered through Quick Response Department.
Add -Z6 for assembly of nuts and ferrules on the tube stub end.

BSP Taper Female Adapter For fractional tube

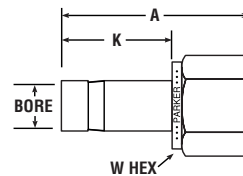
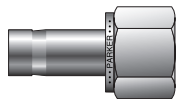

| CPI™ PART NO. | A-LOK® PART NO. | INTER- CHANGES WITH | INCHES | | | | | |
|------------------|--------------------|---------------------------|---------------|----------------|------|-----|----------|------|
| | | | TUBE O. D. | BSPT THREAD | A | K | W HEX | BORE |
| 4-2K T2HG | 4FA2K | 4-TR-7-2RT | 1/4 | 1/8-28 | 1.31 | .64 | 9/16 | .156 |
| 4-4K T2HG | 4FA4K | 4-TR-7-4RT | 1/4 | 1/4-19 | 1.48 | .64 | 3/4 | .156 |
| 6-4K T2HG | 6FA4K | 6-TR-7-4RT | 3/8 | 1/4-19 | 1.56 | .72 | 3/4 | .281 |
| 6-6K T2HG | 6FA6K | 6-TR-7-6RT | 3/8 | 3/8-19 | 1.63 | .72 | 7/8 | .281 |
| 8-4K T2HG | 8FA4K | 8-TR-7-4RT | 1/2 | 1/4-19 | 1.83 | .98 | 3/4 | .375 |
| 8-6K T2HG | 8FA6K | 8-TR-7-6RT | 1/2 | 3/8-19 | 1.89 | .98 | 7/8 | .375 |
| 8-8K T2HG | 8FA8K | 8-TR-7-8RT | 1/2 | 1/2-14 | 2.14 | .98 | 1-1/16 | .375 |

NOTE: Tube stub is pre-grooved as standard.

Dimensions for reference only, subject to change.

Generic (non-grooved) can be ordered through Quick Response Department.
Add -Z6 for assembly of nuts and ferrules on the tube stub end.

BSP Taper Female Adapter For metric tube

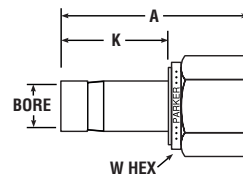
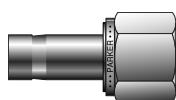

| CPI™ PART NO. | A-LOK® PART NO. | INTER- CHANGES WITH | MILLIMETERS | | | | | |
|------------------|--------------------|---------------------------|---------------|----------------|------|------|----------|------|
| | | | TUBE O. D. | BSPT THREAD | A | K | W HEX | BORE |
| T2HG 3-1/8K | M3FA1/8K | 3-MTA-7-2RT | 3 | 1/8 | 27,8 | 13,5 | 14,0 | 1,8 |
| T2HG 4-1/8K | M4FA1/8K | 4-MTA-7-2RT | 4 | 1/8 | 28,6 | 14,3 | 14,0 | 2,0 |
| T2HG 6-1/8K | M6FA1/8K | 6-MTA-7-2RT | 6 | 1/8 | 30,2 | 15,9 | 14,0 | 4,0 |
| T2HG 8-1/4K | M8FA1/4K | 8-MTA-7-4RT | 8 | 1/4 | 39,1 | 16,7 | 19,0 | 6,4 |
| T2HG 10-1/4K | M10FA1/4K | 10-MTA-7-4RT | 10 | 1/4 | 36,5 | 17,5 | 19,0 | 7,5 |
| T2HG 10-3/8K | M10FA3/8K | 10-MTA-7-6RT | 10 | 3/8 | 31,8 | 17,5 | 22,0 | 7,5 |
| T2HG 10-1/2K | M10FA1/2K | 10-MTA-7-8RT | 10 | 1/2 | 41,3 | 17,5 | 27,0 | 7,5 |
| T2HG 12-1/4K | M12FA1/4K | 12-MTA-7-4RT | 12 | 1/4 | 40,5 | 23,0 | 19,0 | 9,1 |
| T2HG 12-3/8K | M12FA3/8K | 12-MTA-7-6RT | 12 | 3/8 | 43,7 | 23,0 | 22,0 | 9,1 |
| T2HG 12-1/2K | M12FA1/2K | 12-MTA-7-8RT | 12 | 1/2 | 46,8 | 23,0 | 27,0 | 9,1 |
| T2HG 16-1/2K | M16FA1/2K | 16-MTA-7-8RT | 16 | 1/2 | 48,4 | 24,6 | 27,0 | 12,7 |
| T2HG 18-3/4K | M18FA3/4K | 18-MTA-7-12RT | 18 | 3/4 | 51,6 | 24,6 | 32,0 | 14,0 |
| T2HG 20-3/4K | M20FA3/4K | 20-MTA-7-12RT | 20 | 3/4 | 52,4 | 25,4 | 32,0 | 15,1 |
| T2HG 25-1K | M25FA1K | 25-MTA-7-16RT | 25 | 1 | 66,7 | 31,8 | 41,0 | 19,8 |

NOTE: Tube stub is pre-grooved as standard.

Dimensions for reference only, subject to change.

Add -Z6 for assembly of nuts and ferrules on the tube stub end.

BSPP Female Adapter For fractional tube

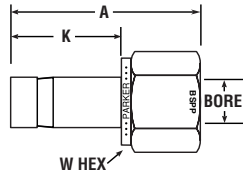
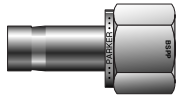

| CPI™ PART NO. | A-LOK® PART NO. | INTER- CHANGES WITH | INCHES | | | | | | |
|------------------|--------------------|---------------------------|--------------|----------------|------|-----|----------|------|--|
| | | | TUBE O.D. | BSPP THREAD | A | K | W HEX | BORE | |
| 4-4R T2HG | 4FA4R | 4-TA-7-4RP | 1/4 | 1/4 | 1.68 | .63 | 3/4 | .18 | |
| 6-6R T2HG | 6FA6R | 6-TA-7-6RP | 3/8 | 3/8 | 1.53 | .69 | 7/8 | .28 | |
| 8-8R T2HG | 8FA8R | 8-TA-7-8RP | 1/2 | 1/2 | 1.91 | .91 | 1-1/16 | .39 | |

NOTE: Copper washer must be used for this design.

Dimensions for reference only, subject to change.

Tube stub is pre-grooved as standard. Generic (non-grooved) can be ordered through Quick Response Department.
Add -Z6 for assembly of nuts and ferrules on the tube stub end.

BSPP Female Adapter For metric tube

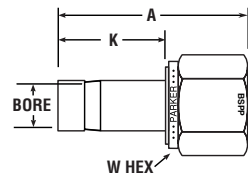
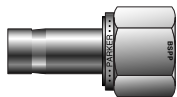

| CPI™ PART NO. | A-LOK® PART NO. | INTER- CHANGES WITH | MILLIMETERS | | | | | | |
|------------------|--------------------|---------------------------|--------------|----------------|------|------|----------|------|--|
| | | | TUBE O.D. | BSPP THREAD | A | K | W HEX | BORE | |
| T2HG 3-1/8R | M3FA1/8R | 3-MTA-7-2RP | 3 | 1/8 | 28,6 | 13,5 | 14,0 | 1,8 | |
| T2HG 3-1/4R | M3FA1/4R | 3-MTA-7-4RP | 3 | 1/4 | 28,6 | 13,7 | 19,0 | 1,6 | |
| T2HG 4-1/8R | M4FA1/8R | 4-MTA-7-2RP | 4 | 1/8 | 29,4 | 14,3 | 14,0 | 2,0 | |
| T2HG 6-1/8R | M6FA1/8R | 6-MTA-7-4RP | 6 | 1/8 | 31,0 | 15,9 | 14,0 | 4,0 | |
| T2HG 6-1/4R | M6FA1/4R | 6-MTA-7-4RP | 6 | 1/4 | 37,3 | 15,9 | 19,0 | 4,0 | |
| T2HG 8-1/4R | M8FA1/4R | 8-MTA-7-4RP | 8 | 1/4 | 38,1 | 16,7 | 19,0 | 6,4 | |
| T2HG 10-1/4R | M10FA1/4R | 10-MTA-7-4RP | 10 | 1/4 | 38,9 | 17,5 | 19,0 | 7,5 | |
| T2HG 10-1/2R | M10FA1/2R | 10-MTA-7-8RP | 10 | 1/2 | 43,7 | 17,5 | 27,0 | 7,5 | |
| T2HG 12-3/8R | M12FA3/8R | 12-MTA-7-6RP | 12 | 3/8 | 44,5 | 23,0 | 22,0 | 9,1 | |
| T2HG 12-1/2R | M12FA1/2R | 12-MTA-7-8RP | 12 | 1/2 | 48,4 | 23,0 | 27,0 | 9,1 | |
| T2HG 16-1/2R | M16FA1/2R | 16-MTA-7-8RP | 16 | 1/2 | 50,0 | 24,6 | 27,0 | 12,7 | |
| T2HG 18-3/4R | M18FA3/4R | 18-MTA-7-12RP | 18 | 3/4 | 53,2 | 24,6 | 33,0 | 14,0 | |
| T2HG 20-3/4R | M20FA3/4R | 20-MTA-7-12RP | 20 | 3/4 | 54,0 | 25,4 | 33,0 | 15,1 | |
| T2HG 25-1R | M25FA1R | 25-MTA-7-16RP | 25 | 1 | 67,5 | 31,8 | 41,0 | 19,8 | |

NOTE: Copper washer must be used for this design.

Dimensions for reference only, subject to change.

Tube stub is pre-grooved as standard. Generic (non-grooved) can be ordered through Quick Response Department.
Add -Z6 for assembly of nuts and ferrules on the tube stub end.

Push-Lok to Tube Adapter For fractional tube

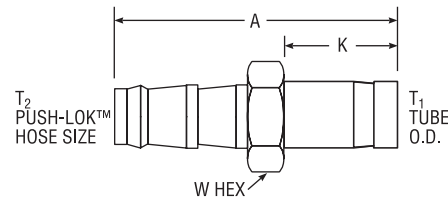
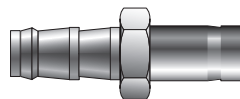

| CPI™ PART NO. | A-LOK® PART NO. | INTER- CHANGES WITH | INCHES | | | | |
|------------------|--------------------|---------------------------|-----------------------------|-----------------------------|------|-----|----------|
| | | | T ₁ TUBE O.D. | T ₂ HOSE SIZE | A | K | W HEX |
| 4-4 P2T2 | 4P2TU4 | PB4-TA4 | 1/4 | -4 | 1.80 | .64 | 7/16 |
| 6-6 P2T2 | 6P2TU6 | PB6-TA6 | 3/8 | -6 | 2.02 | .72 | 9/16 |
| 8-8 P2T2 | 8P2TU8 | PB8-TA8 | 1/2 | -8 | 2.42 | .98 | 11/16 |

NOTE: Drawing does not show Push-Lok collar.

Dimensions for reference only, subject to change.

Tube stub is pre-grooved as standard. Generic (non-grooved) can be ordered through Quick Response Department.
Add -Z6 for assembly of nuts and ferrules on the tube stub end.

Color Coding

For easy reference, table column headings are color indicated as follows:

fractional



metric



Push-Lok to Male Adapter For fractional tube

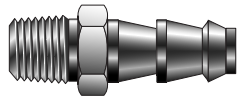

| CPI™ PART NO. | A-LOK® PART NO. | INTER- CHANGES WITH | INCHES | | | | | |
|------------------|--------------------|---------------------------|-----------------------------------|-----------------------------|-------|------|-----|----------|
| | | | T ₂ NPT PIPE THREAD | T ₁ HOSE SIZE | A | B | R | W HEX |
| 4-4 P2HF | 4-4 P2HF | PB4-PM4 | 1/4 | -4 | 1.65 | 0.80 | .56 | 9/16 |
| 6-6 P2HF | 6-6 P2HF | PB6-PM6 | 3/8 | -6 | 1.828 | 0.95 | .56 | 11/16 |
| 8-8 P2HF | 8-8 P2HF | PB8-PM8 | 1/2 | -8 | 2.194 | 1.10 | .75 | 7/8 |

NOTE: Drawing does not show Push-Lok collar.

Dimensions for reference only, subject to change.

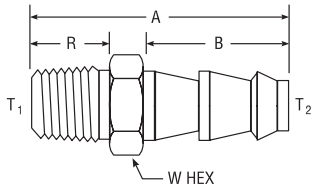

Push-Lok to CPI™/A-LOK® For fractional tube

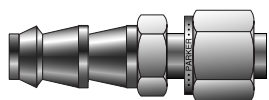

| CPI™ PART NO. | A-LOK® PART NO. | INTER- CHANGES WITH | INCHES | | | | |
|------------------|--------------------|---------------------------|-----------------------------|-----------------------------|------|------|----------|
| | | | T ₁ TUBE O.D. | T ₂ HOSE SIZE | A | K | W HEX |
| 4-4 P2BZ6 | 4-4 P2LZ6 | PB4-TA4 | 1/4 | -4 | 1.77 | 0.72 | 7/16 |
| 6-6 P2BZ6 | 6-6 P2LZ6 | PB6-TA6 | 3/8 | -6 | 1.98 | 0.78 | 9/16 |
| 8-8 P2BZ6 | 8-8 P2LZ6 | PB8-TA8 | 1/2 | -8 | 2.42 | 1.03 | 11/16 |

NOTE: A dimension is typical finger-tight.

Dimensions for reference only, subject to change.

Drawing does not show Push-Lok collar. Assembly includes nut and ferrules.

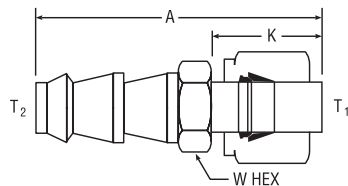

Push-Lok to Port Connector For fractional tube

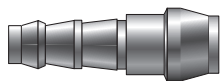

| CPI™ PART NO. | A-LOK® PART NO. | INCHES | | | |
|------------------|--------------------|-----------------------------|-----------------------------|------|-----|
| | | T ₁ HOSE SIZE | T ₂ PORT SIZE | A | B |
| 4-6 ZPB2 | 4-6 ZPC2 | -4 | 3/8 | 1.40 | .80 |

NOTE: Drawing does not show Push-Lok collar and size 6 A-LOK® nut.

Dimensions for reference only, subject to change.

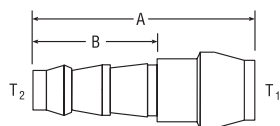

Lapped Joint Tube Adapters For metric tube

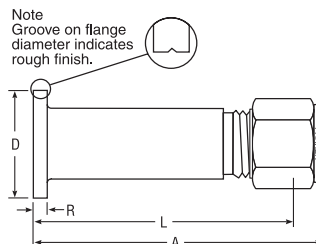
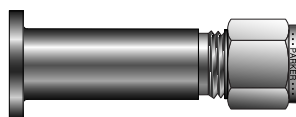

| CPI™ PART NO. | A-LOK® PART NO. | INTER-CHANGES WITH | MILLIMETERS | | | | | | SURFACE FINISH | |
|---------------|-----------------|--------------------|-------------|--------------|------|------|------|-----|----------------|-------------|
| | | | TUBE O.D. | FLANGE SIZE | A | D | L | R | | |
| LJFBZ10-5 | M10LJF-5 | 10M0-1-0005 | 10 | DN15(1/2"NB) | 83,0 | 34,5 | 75,5 | 6,5 | Smooth | 3,2-6,3 Ra |
| LJFBZ10-9 | M10LJF-9 | 10M0-1-0006 | 10 | DN15(1/2"NB) | 83,0 | 34,5 | 75,5 | 6,5 | Rough | 6,3-12,5 Ra |
| LJFBZ12-5 | M12LJF-5 | — | 12 | DN15(1/2"NB) | 85,0 | 34,5 | 75,4 | 6,5 | Smooth | 3,2-6,3 Ra |
| LJFBZ12-9 | M12LJF-9 | — | 12 | DN15(1/2"NB) | 85,0 | 34,5 | 75,4 | 6,5 | Rough | 6,3-12,5 Ra |

NOTE: Groove on flange diameter indicates rough finish.

Dimensions for reference only, subject to change.

The lapped joint tube adaptor is a fitting designed to be used with a lap joint flange which enables a direct hook-up to the instrument tube from the process line.

The compression fitting is incorporated into the body of the adaptor thus the number of components needed for hook-up is reduced. It is therefore cost efficient as well as space saving.

The face of the fitting forms the gasket face of the flange and comes with either a smooth or serrated surface finish. Adapters to suit other tube and flange sizes may be furnished upon request.

For the full line of Manifold Accessories, see Catalog 4190-FP-ACC.

DP Transmitter Calibration Adapters For fractional tube

Parker CPI™/A-LOK® adapters connect directly to the bleed port of a differential pressure transmitter so that the calibration process can be simplified. Two sizes of adapters (1/4-28 Thd., 5/16-24 Thd.) are available to fit the vent ports of Rosemount, Honeywell, and Foxboro DP transmitters. Both adapters are available in 316SS.

| TRANSMITTER TYPE | PARKER PART NO. | INTERCHANGES WITH |
|------------------------|----------------------|-------------------|
| (1) Rosemount/Foxboro | 4-2 ZH2LX-SS-D950373 | — |
| (2) Honeywell | 4-2 ZH2LX-SS-D940336 | SS-400-1-0257 |
| (3) Rosemount/Yokogawa | 4-2 ZH2LX-SS-D030297 | SS-400-1-0253 |
| (4) ABB | 4-2 ZH2LX-SS-D030249 | — |

| STRAIGHT THREAD | INCHES | | | | | | | | | | |
|-----------------|--------|------|-----|------|-----|-----|-----|-----|-----|-----|--|
| | A | B | C | D | E | F | G | H | J | HEX | |
| (1) 5/16-24 | 2.32 | 1.41 | .70 | 2.03 | .24 | .60 | .25 | .06 | .41 | 1/2 | |
| (2) 1/4-28 | 1.75 | .80 | .70 | 1.46 | .47 | .60 | .20 | .03 | — | 1/2 | |
| (3) 5/16-24 | 2.32 | 1.41 | .70 | 2.03 | .40 | .60 | .25 | .05 | .41 | 1/2 | |
| (4) 1/4-28 | 1.74 | .74 | .70 | 1.44 | .30 | .60 | .18 | .05 | — | 1/2 | |

Dimensions for reference only, subject to change.

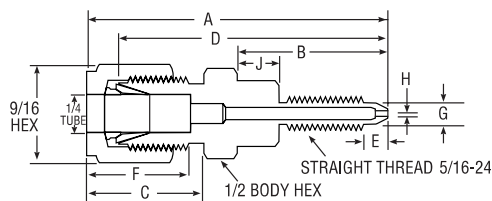
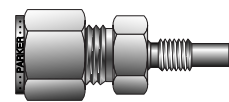
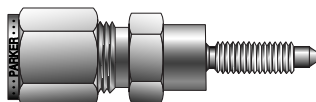

Calibration Adapter for
Rosemount/Foxboro DP Transmitters

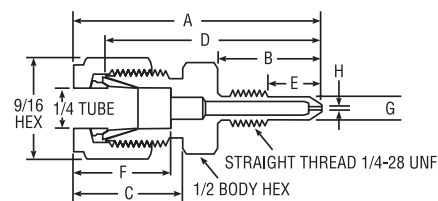

Calibration Adapter for
Honeywell DP Transmitters

Color Coding

For easy reference, table column headings are color indicated as follows:

fractional

metric



37° Flare (AN) to CPI™/A-LOK® For fractional tube

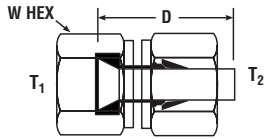
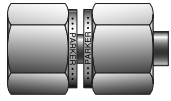

| CPI™ PART NO. | A-LOK® PART NO. | INTER- CHANGES WITH | INCHES | | |
|------------------|--------------------|---------------------------|---------------|------|----------|
| | | | TUBE O. D. | D | W HEX |
| 2-2 X6HBZ6 | 2X6TU2 | 200-A-2 ANF | 1/8 | 0.88 | 3/8 |
| 4-4 X6HBZ6 | 4X6TU4 | 400-A-4 ANF | 1/4 | 0.96 | 9/16 |
| 6-6 X6HBZ6 | 6X6TU6 | 600-A-6 ANF | 3/8 | 1.07 | 11/16 |
| 8-8 X6HBZ6 | 8X6TU8 | 810-A-8 ANF | 1/2 | 1.37 | 7/8 |
| 12-12 X6HBZ6 | 12X6TU12 | 1210-A-12ANF | 3/4 | 1.49 | 1-1/4 |
| 16-16 X6HBZ6 | 16X6TU16 | 1610-A-16ANF | 1 | 1.80 | 1-1/2 |

Dimensions for reference only, subject to change.

37° Flare Connector For fractional tube

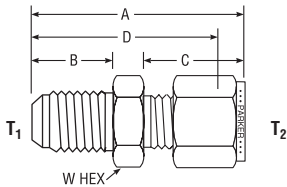
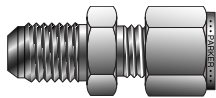

| CPI™ PART NO. | A-LOK® PART NO. | INTER- CHANGES WITH | INCHES | | | | | | |
|------------------|--------------------|---------------------------|--------------|---------------|------|-----|------|------|----------|
| | | | FLARE END | TUBE O. D. | A | B | C | D | W HEX |
| 2-1 XHBZ | 2XASC1 | 100-6-2 AN | 1/8 | 1/16 | 1.07 | .45 | 0.43 | .92 | 7/16 |
| 2-2 XHBZ | 2XASC2 | 200-6-2 AN | 1/8 | 1/8 | 1.28 | .45 | 0.60 | 1.02 | 7/16 |
| 4-2 XHBZ | 4XASC2 | 200-6-4 AN | 1/4 | 1/8 | 1.39 | .55 | 0.60 | 1.13 | 1/2 |
| 3-3 XHBZ | 3XASC3 | 300-6-3 AN | 3/16 | 3/16 | 1.32 | .48 | 0.64 | 1.06 | 7/16 |
| 4-4 XHBZ | 4XASC4 | 400-6-4 AN | 1/4 | 1/4 | 1.48 | .55 | 0.70 | 1.19 | 1/2 |
| 5-5 XHBZ | 5XASC5 | 500-6-5 AN | 5/16 | 5/16 | 1.52 | .55 | 0.73 | 1.22 | 9/16 |
| 4-6 XHBZ | 4XASC6 | 600-6-4 AN | 1/4 | 3/8 | 1.56 | .55 | 0.76 | 1.27 | 5/8 |
| 6-6 XHBZ | 6XASC6 | 600-6-6 AN | 3/8 | 3/8 | 1.56 | .56 | 0.76 | 1.27 | 5/8 |
| 8-8 XHBZ | 8XASC8 | 810-6-8 AN | 1/2 | 1/2 | 1.81 | .66 | 0.87 | 1.41 | 13/16 |
| 10-10 XHBZ | 10XASC10 | 1010-6-10 AN | 5/8 | 5/8 | 1.93 | .76 | 0.87 | 1.53 | 15/16 |
| 12-12 XHBZ | 12XASC12 | 1210-6-12 AN | 3/4 | 3/4 | 2.11 | .86 | 0.87 | 1.70 | 1-1/8 |
| 16-16 XHBZ | 16XASC16 | 1610-6-16 AN | 1 | 1 | 2.43 | .91 | 1.05 | 1.94 | 1-3/8 |

NOTE: A and C dimensions are typical finger-tight.

Dimensions for reference only, subject to change.

37° Flare Bulkhead Connector For fractional tube

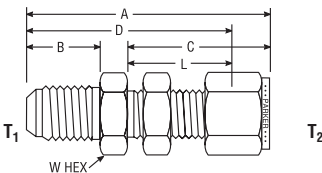
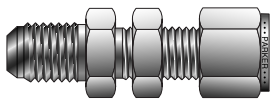

| CPI™ PART NO. | A-LOK® PART NO. | INTER- CHANGES WITH | INCHES | | | | | | | |
|------------------|--------------------|---------------------------|--------------|---------------|------|------|------|------|-----|----------|
| | | | FLARE END | TUBE O. D. | A | D | C | L | B | W HEX |
| 2-2 XH2BZ | 2XABC2 | 200-61-2 AN | 1/8 | 1/8 | 1.91 | 1.65 | 1.23 | 0.97 | .45 | 1/2 |
| 3-3 XH2BZ | 3XABC3 | 300-61-3 AN | 3/16 | 3/16 | 1.98 | 1.71 | 1.26 | 1.00 | .48 | 9/16 |
| 4-2 XH2BZ | 4XABC2 | 200-61-4 AN | 1/4 | 1/8 | 2.04 | 1.78 | 1.23 | 0.97 | .55 | 5/8 |
| 4-4 XH2BZ | 4XABC4 | 400-61-4 AN | 1/4 | 1/4 | 2.12 | 1.83 | 1.31 | 1.02 | .55 | 5/8 |
| 5-5 XH2BZ | 5XABC5 | 500-61-5 AN | 5/16 | 5/16 | 2.21 | 1.92 | 1.41 | 1.12 | .55 | 11/16 |
| 4-6 XH2BZ | 4XABC6 | 600-61-4 AN | 1/4 | 3/8 | 2.25 | 1.96 | 1.44 | 1.15 | .55 | 3/4 |
| 6-6 XH2BZ | 6XABC6 | 600-61-6 AN | 3/8 | 3/8 | 2.25 | 1.96 | 1.44 | 1.15 | .56 | 3/4 |
| 8-8 XH2BZ | 8XABC8 | 810-61-8 AN | 1/2 | 1/2 | 2.59 | 2.19 | 1.65 | 1.25 | .66 | 15/16 |
| 10-10 XH2BZ | 10XABC10 | 1010-61-10 AN | 5/8 | 5/8 | 2.74 | 2.34 | 1.68 | 1.28 | .76 | 1-1/16 |
| 12-12 XH2BZ | 12XABC12 | 1210-61-12 AN | 3/4 | 3/4 | 3.11 | 2.71 | 1.87 | 1.47 | .86 | 1-3/16 |
| 16-16 XH2BZ | 16XABC16 | 1610-61-16 AN | 1 | 1 | 3.65 | 3.16 | 2.27 | 1.78 | .91 | 1-9/16 |

NOTE: A and C dimensions are typical finger-tight.

Dimensions for reference only, subject to change.

For bulkhead hole drill size and maximum bulkhead thickness, see page 29, Part BC

Introduction

BSPP / SAE Straight Thread Fittings Installation Procedure

1. Lubricate O-ring with a lubricant that is compatible with the system.
2. Screw fitting into the straight thread port until the metal back-up washer contacts the face of the port.
3. Position the fitting by backing it out no more than one turn.
4. Hold the fitting in position and tighten the locknut until the washer contacts the face of the port. (See torque chart.)

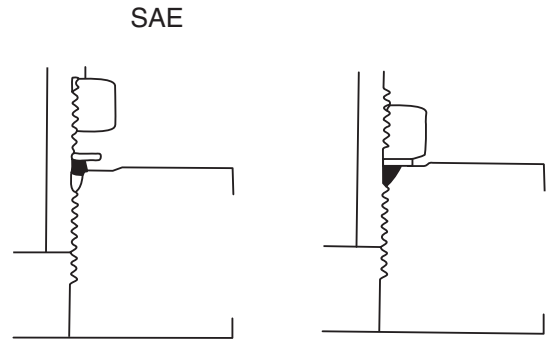
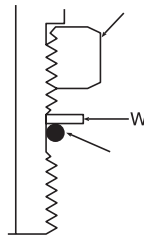

NOTE: WLN Lock Nuts are ordered separately by size and part number. Refer to page 74.

| SIZE | STRAIGHT PORT | | ADJUSTABLE PORT | |
|------|-----------------|------------|-----------------|------------|
| | TORQUE (IN-LBS) | (F.F.F.T.) | TORQUE (IN-LBS) | (F.F.F.T.) |
| 4 | 245 ± 10 | 1.0 ± .25 | 200 ± 10 | 1.5 ± 25 |
| 6 | 630 ± 25 | 1.5 ± .25 | 400 ± 10 | 1.5 ± 25 |
| 8 | 1150 ± 50 | 1.5 ± .25 | 640 ± 10 | 1.5 ± 25 |
| 10 | 1550 ± 50 | 1.5 ± .25 | 1125 ± 50 | 1.5 ± 25 |
| 12 | 2050 ± 50 | 1.5 ± .25 | 1450 ± 50 | 1.5 ± 25 |
| 16 | 3000 ± 50 | 1.5 ± .25 | 2150 ± 50 | 1.5 ± 25 |
| 20 | 3400 ± 100 | 1.5 ± .25 | 2800 ± 100 | 2.0 ± 25 |
| 24 | 4500 ± 100 | 1.5 ± .25 | 3450 ± 100 | 2.0 ± 25 |

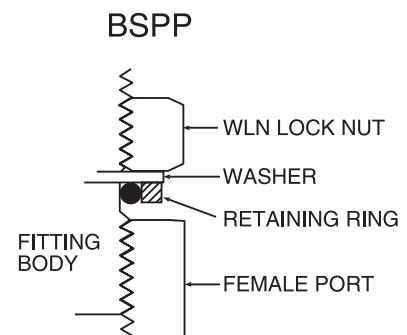

NOTES:

- Restrain fitting body on adjustables if necessary in installation.
- Values in charts are for assemblies with O-ring lubricated.
- Use upper limits of torque ranges for stainless steel fittings.

Face Seal O-Ring Fittings Installation Procedure

The O-ring requires a smooth, flat seating surface. This surface must be perpendicular to the axis of the threads.

1. Turn the O-ring seal fitting in the port until finger tight.
2. The “squeezing” effect on the O-ring can be felt during the last 1/4 turn.
3. Snug lightly with a wrench.

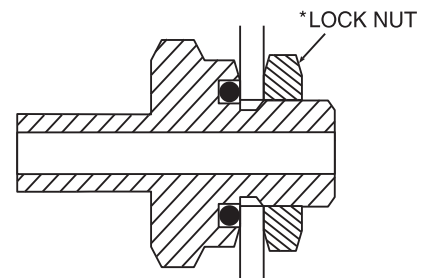

*Typical Application

The fitting can be adapted as a bulkhead fitting on thin wall tanks or vessels, eliminating welding, brazing or threading. Simply order the L5N locknut to take advantage of this option.

Notes:

Standard O-rings are nitrile material. For other O-rings, state material after the part number.

L5N locknuts are ordered separately by size and part number. Refer to page 74.

| PORT SIZE | STRAIGHT THREAD SIZE | STRAIGHT THREAD MACHINE LENGTH | L5N LOCKNUT THICKNESS | MAXIMUM TANK WALL THICKNESS |
|-----------|----------------------|--------------------------------|-----------------------|-----------------------------|
| 2 | 5/16-24 | .297 | .219 | .078 = 5/64 |
| 3 | 3/8-24 | .297 | .219 | .078 = 5/64 |
| 4 | 7/16-20 | .360 | .250 | .109 = 7/65 |
| 5 | 1/2-20 | .360 | .250 | .109 = 7/64 |
| 6 | 9/16-18 | .391 | .265 | .125 = 1/8 |
| 8 | 3/4-16 | .438 | .312 | .125 = 1/8 |
| 10 | 7/8-14 | .500 | .360 | .140 = 9/64 |
| 12 | 1-1/16-12 | .594 | .406 | .188 = 3/16 |
| 14 | 1-13/16-12 | .594 | .406 | .188 = 3/16 |
| 16 | 1-5/16-12 | .594 | .406 | .188 = 3/16 |

O-rings used with SAE/MS straight threads are nitrile. Other O-ring materials are available on request. Lubricate O-ring with a lubricant compatible with the system fluid, environment and O-ring material.



Male Connector to SAE Straight Thread For fractional tube

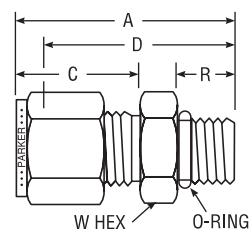
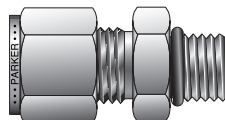

| CPI™ PART NO. | A-LOK® PART NO. | INTER- CHANGES WITH | INCHES | | | | | | O-RING AS UNIFORM DASH NO. | |
|------------------|--------------------|---------------------------|--------------|----------------------------|------|------|------|-----|-------------------------------------|----------|
| | | | TUBE O.D. | STRAIGHT THREAD SIZE | A | C | D | R | | W HEX |
| 1-2 ZHBA | 1M1SC2 | 100-1-2 ST | 1/16 | 5/16-24 | 0.92 | 0.43 | 0.77 | .30 | 7/16 | 3-902 |
| 2-2 ZHBA | 2M1SC2 | 200-1-2 ST | 1/8 | 5/16-24 | 1.18 | 0.60 | 0.92 | .30 | 7/16 | 3-902 |
| 2-6 ZHBA | 2M1SC6 | 200-1-6 ST | 1/8 | 9/16-18 | 1.35 | 0.60 | 1.06 | .39 | 11/16 | 3-906 |
| 3-3 ZHBA | 3M1SC3 | 300-1-3 ST | 3/16 | 3/8-24 | 1.20 | 0.64 | 0.94 | .30 | 1/2 | 3-903 |
| 4-4 ZHBA | 4M1SC4 | 400-1-4 ST | 1/4 | 7/16-20 | 1.34 | 0.70 | 1.05 | .36 | 9/16 | 3-904 |
| 4-6 ZHBA | 4M1SC6 | 400-1-6 ST | 1/4 | 9/16-18 | 1.40 | 0.70 | 1.11 | .39 | 11/16 | 3-906 |
| 4-8 ZHBA | 4M1SC8 | 400-1-8 ST | 1/4 | 3/4-16 | 1.48 | 0.70 | 1.19 | .44 | 7/8 | 3-908 |
| 4-10 ZHBA | 4M1SC10 | 400-1-10 ST | 1/4 | 7/8-14 | 1.60 | 0.70 | 1.31 | .50 | 1 | 3-910 |
| 5-5 ZHBA | 5M1SC5 | 500-1-5 ST | 5/16 | 1/2-20 | 1.37 | 0.73 | 1.08 | .36 | 5/8 | 3-905 |
| 6-4 ZHBA | 6M1SC4 | 600-1-4 ST | 3/8 | 7/16-20 | 1.40 | 0.76 | 1.11 | .36 | 5/8 | 3-904 |
| 6-6 ZHBA | 6M1SC6 | 600-1-6 ST | 3/8 | 9/16-18 | 1.46 | 0.76 | 1.17 | .39 | 11/16 | 3-906 |
| 6-8 ZHBA | 6M1SC8 | 600-1-8 ST | 3/8 | 3/4-16 | 1.54 | 0.76 | 1.25 | .44 | 7/8 | 3-908 |
| 6-10 ZHBA | 6M1SC10 | 600-1-10 ST | 3/8 | 7/8-14 | 1.67 | 0.76 | 1.38 | .50 | 1.00 | 3-910 |
| 8-6 ZHBA | 8M1SC6 | 810-1-6 ST | 1/2 | 9/16-18 | 1.54 | 0.87 | 1.14 | .39 | 7/8 | 3-906 |
| 8-8 ZHBA | 8M1SC8 | 810-1-8 ST | 1/2 | 3/4-16 | 1.65 | 0.87 | 1.25 | .44 | 7/8 | 3-908 |
| 8-12 ZHBA | 8M1SC12 | 810-1-12 ST | 1/2 | 1-1/16-12 | 1.93 | 0.87 | 1.53 | .59 | 1-1/4 | 3-912 |
| 10-10 ZHBA | 10M1SC10 | 1010-1-10 ST | 5/8 | 7/8-14 | 1.78 | 0.87 | 1.38 | .50 | 1 | 3-910 |
| 12-10 ZHBA | 12M1SC10 | 1210-1-10 ST | 3/4 | 7/8-14 | 1.68 | 0.87 | 1.28 | .50 | 1-1/8 | 3-910 |
| 12-12 ZHBA | 12M1SC12 | 1210-1-12 ST | 3/4 | 1-1/16-12 | 1.93 | 0.87 | 1.53 | .59 | 1-1/4 | 3-912 |
| 12-14 ZHBA | 14M1SC14 | 1410-1-14 ST | 7/8 | 1-3/16-12 | 1.93 | 0.87 | 1.53 | .59 | 1-3/8 | 3-914 |
| 16-12 ZHBA | 16M1SC12 | 1610-1-12 ST | 1 | 1-1/16-12 | 2.12 | 1.05 | 1.63 | .59 | 1-3/8 | 3-912 |
| 16-16 ZHBA | 16M1SC16 | 1610-1-16 ST | 1 | 1-5/16-12 | 2.15 | 1.04 | 1.66 | .59 | 1-1/2 | 3-916 |
| 20-20 ZHBA | 20M1SC20 | 2010-1-20 ST | 1-1/4 | 1-5/8-12 | 2.59 | 1.52 | 1.82 | .59 | 1-7/8 | 3-920 |
| 24-24 ZHBA | 24M1SC24 | 2410-1-24 ST | 1-1/2 | 1-7/8-12 | 3.05 | 1.77 | 1.99 | .59 | 2-1/8 | 3-924 |
| 32-32 ZHBA | 32M1SC32 | 3210-1-32 ST | 2 | 2-1/2-12 | 4.00 | 2.47 | 2.53 | .59 | 2-3/4 | 3-932 |

NOTE: A and C dimensions are typical finger-tight.

Dimensions for reference only, subject to change.

For use with SAE J.1926/1 port can also be used with MS-16142 port.

Sizes 20, 24, 32 require additional lubrication prior to assembly.

Parts are supplied with nitrile o-rings as standard. For Fluorocarbon o-rings, add the suffix "-VO". Other o-rings available upon request.

Color Coding

For easy reference, table column headings are color indicated as follows:

fractional



metric



Male SAE Straight Thread Elbow For fractional tube

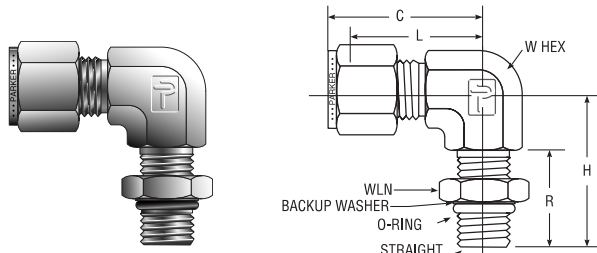

| CPI™ PART NO. | A-LOK® PART NO. | INTER-CHANGES WITH | INCHES | | | | | | | O-RING ARP UNIFORM DASH NO. |
|------------------|--------------------|--------------------|--------------|----------------------------|------|------|------|------|----------|--------------------------------------|
| | | | TUBE O.D. | STRAIGHT THREAD SIZE | C | H | L | R | W HEX | |
| 4-4 C5BZ | 4M5SEL4 | 400-2-4ST | 1/4 | 7/16-20 | 1.12 | 1.18 | 0.83 | 0.83 | 9/16 | 3-904 |
| 6-6 C5BZ | 6M5SEL6 | 600-2-6ST | 3/8 | 9/16-18 | 1.26 | 1.27 | 0.97 | 0.84 | 9/16 | 3-906 |
| 8-8 C5BZ | 8M5SEL8 | 810-2-8ST | 1/2 | 3/4-16 | 1.48 | 1.48 | 1.08 | 0.97 | 3/4 | 3-908 |
| 12-12 C5BZ | 12M5SEL12 | 1210-2-12ST | 3/4 | 1-1/16-12 | 1.63 | 1.92 | 1.23 | 1.28 | 1-1/16 | 3-912 |
| 16-16 C5BZ | 16M5SEL16 | 1610-2-16ST | 1 | 1-5/16-12 | 1.91 | 2.11 | 1.42 | 1.28 | 1-5/16 | 3-916 |
| 24-24 C5BZ | 24M5SEL24 | 2410-2-24ST | 1-1/2 | 1-7/8-12 | 3.47 | 2.33 | 2.00 | 1.16 | 1-7/8 | 3-924 |

NOTE: C dimension is typical finger-tight.

Dimensions for reference only, subject to change.

Size 24 requires additional lubrication prior to assembly.

Parts are supplied with nitrile o-rings as standard. For Fluorocarbon o-rings, add the suffix "-VO". Other o-rings available upon request.

BSPP Male Elbow (Positionable) For fractional tube

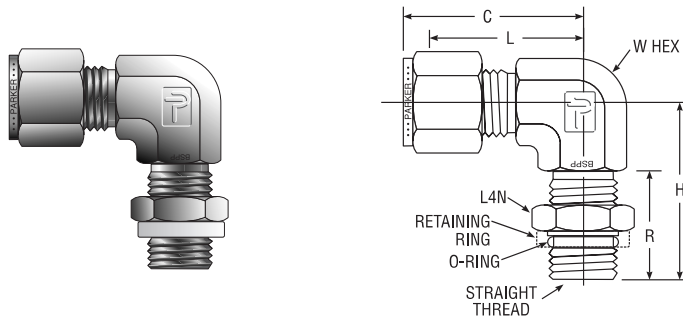

| CPI™ PART NO. | A-LOK® PART NO. | INTER-CHANGES WITH | INCHES | | | | | | |
|------------------|--------------------|--------------------|--------------|----------------|------|------|------|------|----------|
| | | | TUBE O.D. | BSPP THREAD | C | H | L | R | W HEX |
| 4-2R CBZ | 4MSEL2R | 400-2-2PR | 1/4 | 1/8-28 | 1.06 | 1.04 | 0.77 | 0.81 | 9/16 |
| 4-4R CBZ | 4MSEL4R | 400-2-4PR | 1/4 | 1/4-19 | 1.14 | 1.27 | 0.85 | 0.83 | 9/16 |
| 6-4R CBZ | 6MSEL4R | 600-2-4PR | 3/8 | 1/4-19 | 1.20 | 1.27 | 0.85 | 0.83 | 9/16 |
| 6-6R CBZ | 6MSEL6R | 600-2-6PR | 3/8 | 3/8-19 | 1.31 | 1.46 | 1.02 | 0.83 | 3/4 |
| 8-8R CBZ | 8MSEL4R | 810-2-4PR | 1/2 | 1/4-19 | 1.50 | 1.38 | 1.10 | 0.83 | 7/8 |
| 8-6R CBZ | 8MSEL6R | 810-2-6PR | 1/2 | 3/8-19 | 1.50 | 1.46 | 1.10 | 0.85 | 7/8 |
| 8-8R CBZ | 8MSEL8R | 810-2-8PR | 1/2 | 1/2-14 | 1.50 | 1.71 | 1.10 | 1.09 | 7/8 |
| 10-10R CBZ | 10MSEL8R | 1010-2-8PR | 5/8 | 1/2-14 | 1.50 | 1.81 | 1.10 | 1.09 | 1-1/16 |
| 12-8R CBZ | 12MSEL8R | 1210-2-8PR | 3/4 | 1/2-14 | 1.57 | 1.81 | 1.17 | 1.09 | 1-1/16 |
| 12-12R CBZ | 12MSEL12R | 1210-2-12PR | 3/4 | 3/4-14 | 1.57 | 1.92 | 1.17 | 1.20 | 1-1/16 |
| 16-12R CBZ | 16MSEL12R | 1610-2-12PR | 1 | 3/4-14 | 1.93 | 2.11 | 1.45 | 1.20 | 1-5/16 |
| 16-16R CBZ | 16MSEL16R | 1610-2-16PR | 1 | 1-11 | 1.93 | 2.11 | 1.45 | 1.20 | 1-5/16 |

NOTE: C dimension is typical finger-tight.

Dimensions for reference only, subject to change.

Connects fractional tube to female ISO parallel thread.

Parts are supplied with nitrile o-rings as standard. For Fluorocarbon o-rings, add the suffix "-VO". Other o-rings available upon request.

Color Coding

For easy reference, table column headings are color indicated as follows:

fractional

metric



Male Run Tee SAE Straight Thread For fractional tube

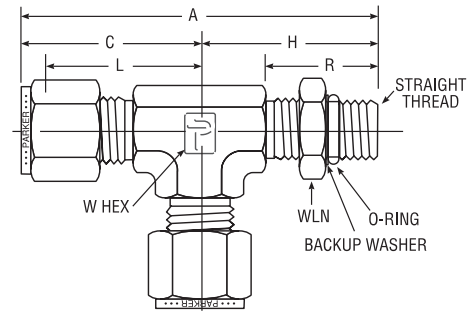
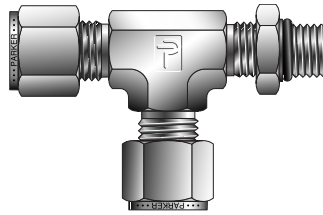

| CPI™ PART NO. | A-LOK® PART NO. | INTER- CHANGES WITH | INCHES | | | | | | | | O-RING ARP UNIFORM DASH NO. |
|------------------|--------------------|---------------------------|--------------|---------------------------|------|------|------|------|------|----------|--------------------------------------|
| | | | TUBE O.D. | TRAIGHT THREAD SIZE | A | C | H | L | R | W HEX | |
| 4-4-4 R5BZ | 4M5RT4 | 400-3TST | 1/4 | 7/16-20 | 2.24 | 1.12 | 1.18 | 0.83 | 0.83 | 7/16 | 3-904 |
| 6-6-6 R5BZ | 6M5RT6 | 600-3TST | 3/8 | 9/16-18 | 2.53 | 1.26 | 1.27 | 0.97 | 0.84 | 9/16 | 3-906 |
| 8-8-8 R5BZ | 8M5RT8 | 810-3TST | 1/2 | 3/4-16 | 2.97 | 1.48 | 1.48 | 1.08 | 0.97 | 3/4 | 3-908 |
| 12-12-12 R5BZ | 12M5RT12 | 1210-3TST | 3/4 | 1-1/16-12 | 3.55 | 1.63 | 1.92 | 1.23 | 1.28 | 1-1/16 | 3-912 |
| 16-16-16 R5BZ | 16M5RT16 | 1610-3TST | 1 | 1-5/16-12 | 3.74 | 1.87 | 2.11 | 1.38 | 1.28 | 1-5/16 | 3-916 |

NOTE: A and C dimensions are typical finger-tight.

Dimensions for reference only, subject to change.

Parts are supplied with nitrile o-rings as standard. For Fluorocarbon o-rings, add the suffix "-VO". Other o-rings available upon request.

BSPP Male Run Tee (Positionable) For fractional tube

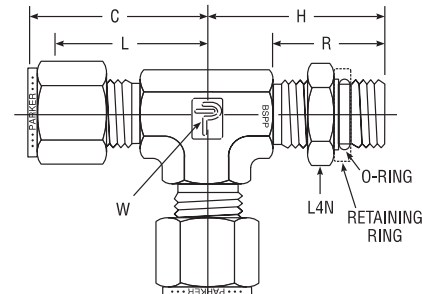
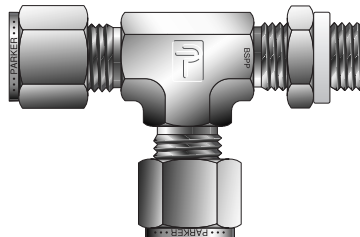

| CPI™ PART NO. | A-LOK® PART NO. | INTER- CHANGES WITH | INCHES | | | | | | |
|------------------|--------------------|---------------------------|--------------|----------------|------|------|------|------|----------|
| | | | TUBE O.D. | BSPP THREAD | C | H | L | R | W HEX |
| 4-2R-4 RBZ | 4MRT2R | 400-3TRT | 1/4 | 1/8-28 | 1.06 | 1.04 | 0.77 | 0.81 | 9/16 |
| 4-4R-4 RBZ | 4MRT4R | 400-3-4TRT | 1/4 | 1/4-19 | 1.14 | 1.27 | 0.85 | 0.83 | 9/16 |
| 6-6R-6 RBZ | 6MRT6R | 600-3TRT | 3/8 | 1/4-19 | 1.20 | 1.27 | 0.91 | 0.83 | 9/16 |
| 8-6R-8 RBZ | 8MRT8R | 810-3TRT | 1/2 | 3/8-19 | 1.50 | 1.46 | 1.10 | 0.85 | 7/8 |
| 8-8R-8 RBZ | 8MRT8R | 810-3-8TRT | 1/2 | 1/2-14 | 1.50 | 1.71 | 1.10 | 1.09 | 7/8 |
| 10-8R-10 RBZ | 10MRT8R | 1010-3TRT | 5/8 | 1/2-14 | 1.50 | 1.81 | 1.10 | 1.09 | 1-1/16 |
| 12-8R-12 RBZ | 12MRT8R | 1210-3-8TRT | 3/4 | 1/2-14 | 1.57 | 1.81 | 1.17 | 1.09 | 1-1/16 |
| 12-12R-12 RBZ | 12MRT12R | 1210-3TRT | 3/4 | 3/4-14 | 1.57 | 1.92 | 1.17 | 1.20 | 1-1/16 |
| 16-16R-16 RBZ | 16MRT16R | 1610-3TRT | 1 | 1-11 | 1.93 | 2.11 | 1.45 | 1.20 | 1-5/16 |

NOTE: C dimension is typical finger-tight.

Dimensions for reference only, subject to change.

Parts are supplied with nitrile o-rings as standard. For Fluorocarbon o-rings, add the suffix "-VO". Other o-rings available upon request.

Male Branch Tee SAE Straight Thread For fractional tube

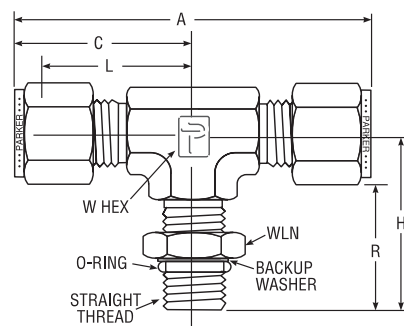
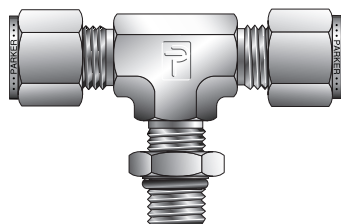

| CPI™ PART NO. | A-LOK® PART NO. | INTER- CHANGES WITH | INCHES | | | | | | | | O-RING ARP UNIFORM DASH NO. |
|------------------|--------------------|---------------------------|--------------|----------------------------|------|------|------|------|------|----------|--------------------------------------|
| | | | TUBE O.D. | STRAIGHT THREAD SIZE | A | C | H | L | R | W HEX | |
| 4-4-4 S5BZ | 4M5BT4 | 400-3TTS | 1/4 | 7/16-20 | 2.24 | 1.19 | 1.19 | 0.81 | 0.81 | 7/16 | 3-904 |
| 6-6-6 S5BZ | 6M5BT6 | 600-3TTS | 3/8 | 9/16-18 | 2.52 | 1.26 | 1.27 | 0.97 | 0.84 | 9/16 | 3-906 |
| 8-8-8 S5BZ | 8M5BT8 | 810-3TTS | 1/2 | 3/4-16 | 2.96 | 1.48 | 1.48 | 1.08 | 0.97 | 3/4 | 3-908 |
| 12-12-12 S5BZ | 12M5BT12 | 1210-3TTS | 3/4 | 1-1/16-12 | 3.26 | 1.63 | 1.92 | 1.23 | 1.28 | 1-1/16 | 3-912 |
| 16-16-16 S5BZ | 16M5BT16 | 1610-3TTS | 1 | 1-5/16-12 | 3.74 | 1.87 | 2.11 | 1.38 | 1.28 | 1-5/16 | 3-916 |

NOTE: A and C dimensions are typical finger-tight.

Dimensions for reference only, subject to change.

Parts are supplied with nitrile o-rings as standard. For Fluorocarbon o-rings, add the suffix "-VO". Other o-rings available upon request.

BSPP Male Branch Tee (Positionable) For fractional tube

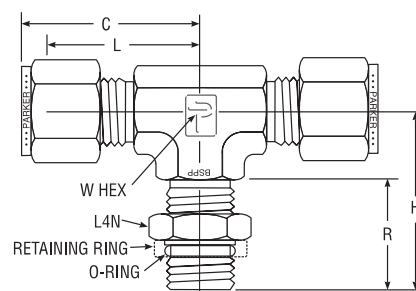
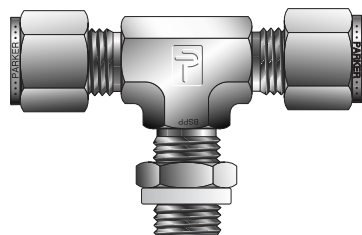

| CPI™ PART NO. | A-LOK® PART NO. | INTER- CHANGES WITH | INCHES | | | | | | | W HEX |
|------------------|--------------------|---------------------------|--------------|----------------|------|------|------|------|--------|----------|
| | | | TUBE O.D. | BSPP THREAD | C | H | L | R | | |
| 4-4-2R SBZ | 4MBT2R | 400-3TTR | 1/4 | 1/8-28 | 1.06 | 1.25 | 0.77 | 0.81 | 9/16 | |
| 4-4-4R SBZ | 4MBT4R | 400-3-4TTR | 1/4 | 1/4-19 | 1.14 | 1.27 | 0.85 | 0.83 | 9/16 | |
| 6-6-4R SBZ | 6MBT4R | 600-3TTR | 3/8 | 1/4-19 | 1.20 | 1.27 | 0.91 | 0.83 | 9/16 | |
| 8-8-6R SBZ | 8MBT6R | 810-3TTR | 1/2 | 3/8-19 | 1.50 | 1.36 | 1.10 | 0.85 | 7/8 | |
| 8-8-8R SBZ | 8MBT8R | 810-3-8TTR | 1/2 | 1/2-14 | 1.50 | 1.71 | 1.10 | 1.09 | 7/8 | |
| 10-10-8R SBZ | 10MBT8R | 1010-3TTR | 5/8 | 1/2-14 | 1.50 | 1.81 | 1.10 | 1.09 | 1-1/16 | |
| 12-12-8R SBZ | 12MBT8R | 1210-3-8TTR | 3/4 | 1/2-14 | 1.57 | 1.81 | 1.17 | 1.09 | 1-1/16 | |
| 12-12-12R SBZ | 12MBT12R | 1210-3-TTR | 3/4 | 3/4-14 | 1.57 | 1.92 | 1.17 | 1.20 | 1-1/16 | |
| 16-16-16R SBZ | 16MBT16R | 1610-3TTR | 1 | 1-11 | 1.94 | 2.11 | 1.45 | 1.20 | 1-5/16 | |

NOTE: C dimension is typical finger-tight.

Dimensions for reference only, subject to change.

Connects fractional tube to female ISO parallel thread.

Parts are supplied with nitrile o-rings as standard. For Fluorocarbon o-rings, add the suffix "-VO". Other o-rings available upon request.

Color Coding

For easy reference, table column headings are color indicated as follows:

fractional

metric



Long Male Connector SAE/MS Straight Thread For fractional tube

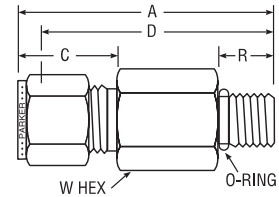
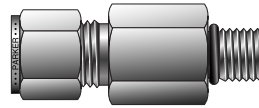

| CPI™ PART NO. | A-LOK® PART NO. | INTER- CHANGES WITH | INCHES | | | | | | | ST O-RING UNIFORM SIZE NO. | |
|------------------|--------------------|---------------------------|-------------------|----------------------------|------|-----|------|------|----------------------|-------------------------------------|----------|
| | | | T TUBE O.D. | S-SAE/MS THREAD SIZE | A | R | C | D | E MIN. OPENING | | W HEX |
| 4-4 ZH3BA | 4-4 ZH3LA | 400-1L-4ST | 1/4 | 7/16-20 | 2.26 | .36 | 0.70 | 1.97 | .19 | 9/16 | -904 |
| 6-6 ZH3BA | 6-6 ZH3LA | 600-1L-6ST | 3/8 | 9/16-18 | 2.48 | .39 | 0.76 | 2.19 | .28 | 11/16 | -906 |
| 8-8 ZH3BA | 8-8 ZH3LA | 810-1L-8ST | 1/2 | 3/4-16 | 3.01 | .44 | 0.86 | 2.58 | .41 | 7/8 | -908 |
| 12-12 ZH3BA | 12-12 ZH3LA | 1210-1L-12ST | 3/4 | 1-1/16-12 | 3.88 | .59 | 0.86 | 3.48 | .62 | 1-1/4 | -912 |
| 16-16 ZH3BA | 16-16 ZH3LA | 1610-1L-16ST | 1 | 1-5/16-12 | 4.34 | .59 | 1.04 | 3.86 | .88 | 1-1/2 | -916 |

NOTE: A and C dimensions are typical finger-tight.

Dimensions for reference only, subject to change.

Parts are supplied with nitrile o-rings as standard. For Fluorocarbon o-rings, add the suffix "-VO". Other o-rings available upon request.

45° Positionable Male Elbow SAE/MS Straight Thread For fractional tube

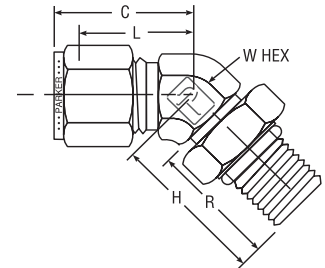
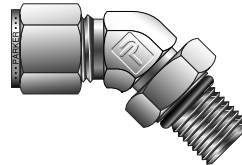

| CPI™ PART NO. | A-LOK® PART NO. | INTER- CHANGES WITH | INCHES | | | | | | | O-RING UNIFORM DASH NO. |
|------------------|--------------------|---------------------------|--------------------------|----------------|------|------|------|------|----------|-------------------------------|
| | | | STRAIGHT TUBE O.D. | THREAD SIZE | C | H | L | R | W HEX | |
| 4-4 V5BZ | 4M5VEL4 | 400-5-4ST | 1/4 | 7/16-20 | 0.93 | 1.02 | 0.65 | 0.75 | 7/16 | 3-904 |
| 6-6 V5BZ | 6M5VEL6 | 600-5-6ST | 3/8 | 9/16-18 | 1.01 | 1.27 | 0.72 | 0.77 | 9/16 | 3-906 |
| 8-8 V5BZ | 8M5VEL8 | 810-5-8ST | 1/2 | 3/4-16 | 1.15 | 1.48 | 0.75 | 0.88 | 3/4 | 3-908 |
| 12-12 V5BZ | 12M5VEL12 | 1210-5-12ST | 3/4 | 1-1/16-12 | 1.63 | 1.92 | 1.23 | 1.16 | 1-1/16 | 3-912 |
| 16-16 V5BZ | 16M5VEL16 | 1610-5-16ST | 1 | 1-5/16-12 | 1.87 | 2.11 | 1.39 | 1.16 | 1-5/16 | 3-916 |

NOTE: C dimension is typical finger-tight.

Dimensions for reference only, subject to change.

• Adapts to SAE J1926 straight thread boss and MS16142 boss.

Parts are supplied with nitrile o-rings as standard. For Fluorocarbon o-rings, add the suffix "-VO". Other o-rings available upon request.

Male Connector to O-Ring Straight Thread

For fractional tube

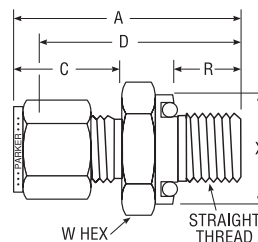
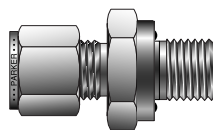

| CPI™ PART NO. | A-LOK® PART NO. | INTER-CHANGES WITH | INCHES | | | | | | | | O-RING ARP UNIFORM DASH NO. |
|---------------|-----------------|--------------------|------------|----------------------|------|------|------|-----|--------|-------|-----------------------------|
| | | | TUBE O. D. | STRAIGHT THREAD SIZE | A | C | D | R | X DIA. | W HEX | |
| 1-2 ZHBA5 | 1M2SC2 | 100-1-OR | 1/16 | 5/16-24 | 1.06 | 0.43 | 0.91 | .34 | .55 | 9/16 | 2-011 |
| 2-2 ZHBA5 | 2M2SC2 | 200-1-OR | 1/8 | 5/16-24 | 1.29 | 0.60 | 1.03 | .34 | .55 | 9/16 | 2-011 |
| 3-3 ZHBA5 | 3M2SC3 | 300-1-OR | 3/16 | 3/8-24 | 1.35 | 0.64 | 1.09 | .38 | .62 | 5/8 | 2-012 |
| 4-4 ZHBA5 | 4M2SC4 | 400-1-OR | 1/4 | 7/16-20 | 1.51 | 0.70 | 1.22 | .41 | .74 | 3/4 | 2-111 |
| 5-5 ZHBA5 | 5M2SC5 | 500-1-OR | 5/16 | 1/2-20 | 1.61 | 0.73 | 1.31 | .44 | .86 | 7/8 | 2-112 |
| 6-6 ZHBA5 | 6M2SC6 | 600-1-OR | 3/8 | 9/16-18 | 1.67 | 0.76 | 1.38 | .44 | .93 | 15/16 | 2-113 |
| 8-8 ZHBA5 | 8M2SC8 | 810-1-OR | 1/2 | 3/4-16 | 1.81 | 0.87 | 1.41 | .47 | 1.12 | 1-1/8 | 2-116 |
| 10-10 ZHBA5 | 10M2SC10 | 1010-1-OR | 5/8 | 7/8-14 | 1.90 | 0.87 | 1.50 | .47 | 1.30 | 1-3/8 | 2-212 |
| 12-12 ZHBA5 | 12M2SC12 | 1210-1-OR | 3/4 | 1-1/16-12 | 2.06 | 0.87 | 1.66 | .56 | 1.49 | 1-1/2 | 2-215 |
| 14-12 ZHBA5 | 14M2SC12 | 1410-1-OR | 7/8 | 1-1/16-12 | 2.06 | 0.87 | 1.66 | .56 | 1.49 | 1-1/2 | 2-215 |
| 16-16 ZHBA5 | 16M2SC16 | 1610-1-OR | 1 | 1-5/16-12 | 2.30 | 1.05 | 1.81 | .56 | 1.74 | 1-3/4 | 2-219 |

NOTE: A and C dimensions are typical finger-tight.

Dimensions for reference only, subject to change.

Parts are supplied with nitrile o-rings as standard. For Fluorocarbon o-rings, add the suffix "-VO". Other o-rings available upon request.

Male Connector to O-Ring Pipe Thread

For fractional tube

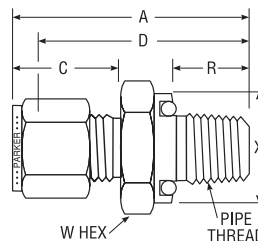
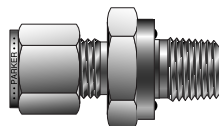

| CPI™ PART NO. | A-LOK® PART NO. | INTER-CHANGES WITH | INCHES | | | | | | | | O-RING ARP UNIFORM DASH NO. |
|---------------|-----------------|--------------------|------------|---------------|------|------|------|-----|--------|-------|-----------------------------|
| | | | TUBE O. D. | NPT PIPE SIZE | A | C | D | R | X DIA. | W HEX | |
| 1-2 ZHBF5 | 1M3SC2 | 100-1-2-OR | 1/16 | 1/8 | 1.12 | 0.43 | 0.97 | .28 | .74 | 3/4 | 2-111 |
| 2-2 ZHBF5 | 2M3SC2 | 200-1-2-OR | 1/8 | 1/8 | 1.29 | 0.60 | 1.03 | .28 | .74 | 3/4 | 2-111 |
| 2-4 ZHBF5 | 2M3SC4 | 200-1-4-OR | 1/8 | 1/4 | 1.43 | 0.60 | 1.17 | .38 | .93 | 15/16 | 2-113 |
| 3-2 ZHBF5 | 3M3SC2 | 300-1-2-OR | 3/16 | 1/8 | 1.32 | 0.64 | 1.06 | .28 | .74 | 3/4 | 2-111 |
| 3-4 ZHBF5 | 3M3SC4 | 300-1-4-OR | 3/16 | 1/4 | 1.46 | 0.64 | 1.20 | .38 | .93 | 15/16 | 2-113 |
| 4-2 ZHBF5 | 4M3SC2 | 400-1-2-OR | 1/4 | 1/8 | 1.38 | 0.70 | 1.09 | .28 | .74 | 3/4 | 2-111 |
| 4-4 ZHBF5 | 4M3SC4 | 400-1-4-OR | 1/4 | 1/4 | 1.51 | 0.70 | 1.22 | .38 | .93 | 15/16 | 2-113 |
| 4-6 ZHBF5 | 4M3SC6 | 400-1-6-OR | 1/4 | 3/8 | 1.57 | 0.70 | 1.28 | .41 | 1.12 | 1-1/8 | 2-116 |
| 5-2 ZHBF5 | 5M3SC2 | 500-1-2-OR | 5/16 | 1/8 | 1.43 | 0.73 | 1.13 | .28 | .74 | 3/4 | 2-111 |
| 5-4 ZHBF5 | 5M3SC4 | 500-1-4-OR | 5/16 | 1/4 | 1.46 | 0.73 | 1.25 | .38 | .93 | 15/16 | 2-113 |
| 6-2 ZHBF5 | 6M3SC2 | 600-1-2-OR | 3/8 | 1/8 | 1.45 | 0.76 | 1.16 | .28 | .74 | 3/4 | 2-111 |
| 6-4 ZHBF5 | 6M3SC4 | 600-1-4-OR | 3/8 | 1/4 | 1.57 | 0.76 | 1.28 | .38 | .93 | 15/16 | 2-113 |
| 6-6 ZHBF5 | 6M3SC6 | 600-1-6-OR | 3/8 | 3/8 | 1.63 | 0.76 | 1.34 | .41 | 1.12 | 1-1/8 | 2-116 |
| 6-8 ZHBF5 | 6M3SC8 | 600-1-8-OR | 3/8 | 1/2 | 1.85 | 0.76 | 1.56 | .53 | 1.30 | 1-3/8 | 2-212 |
| 8-4 ZHBF5 | 8M3SC4 | 810-1-4-OR | 1/2 | 1/4 | 1.68 | 0.87 | 1.28 | .38 | .93 | 15/16 | 2-113 |
| 8-6 ZHBF5 | 8M3SC6 | 810-1-6-OR | 1/2 | 3/8 | 1.76 | 0.87 | 1.36 | .41 | 1.12 | 1-1/8 | 2-116 |
| 8-8 ZHBF5 | 8M3SC8 | 810-1-8-OR | 1/2 | 1/2 | 1.98 | 0.87 | 1.58 | .53 | 1.30 | 1-3/8 | 2-212 |
| 10-8 ZHBF5 | 10M3SC8 | 1010-1-8-OR | 5/8 | 1/2 | 1.96 | 0.87 | 1.56 | .53 | 1.30 | 1-3/8 | 2-212 |
| 10-12 ZHBF5 | 10M3SC12 | 1010-1-8-OR | 5/8 | 3/4 | 2.06 | 0.87 | 1.66 | .56 | 1.49 | 1-1/2 | 2-215 |
| 12-8 ZHBF5 | 12M3SC8 | 1210-1-8-OR | 3/4 | 1/2 | 1.98 | 0.87 | 1.58 | .53 | 1.30 | 1-3/8 | 2-212 |
| 12-12 ZHBF5 | 12M3SC12 | 1210-1-12-OR | 3/4 | 3/4 | 2.06 | 0.87 | 1.66 | .56 | 1.49 | 1-1/2 | 2-215 |
| 16-12 ZHBF5 | 16M3SC12 | 1610-1-12-OR | 1 | 3/4 | 2.24 | 1.05 | 1.75 | .56 | 1.49 | 1-1/2 | 2-215 |
| 16-16 ZHBF5 | 16M3SC16 | 1610-1-16-OR | 1 | 1 | 2.40 | 1.05 | 1.91 | .66 | 1.74 | 1-3/4 | 2-219 |

NOTE: A and C dimensions are typical finger-tight.

Dimensions for reference only, subject to change.

Parts are supplied with nitrile o-rings as standard. For Fluorocarbon o-rings, add the suffix "-VO". Other o-rings available upon request.



Tube End to O-Ring Straight Thread

For fractional tube

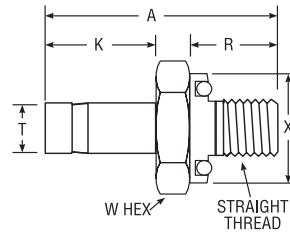
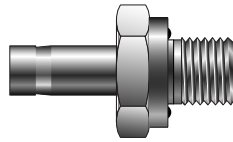

| CPI™ PART NO. | A-LOK® PART NO. | INTER- CHANGES WITH | INCHES | | | | | | | O-RING ARP UNIFORM DASH NO. |
|------------------|--------------------|---------------------------|-------------------|-----------------------|------|------|-----|-----------|----------|--------------------------------------|
| | | | T TUBE O.D. | NPT PIPE THREAD | A | K | R | X DIA. | W HEX | |
| 2-2 T2HOA5 | 2M2TU2 | 2-TA-OR-ST | 1/8 | 5/16-24 | 1.22 | 0.53 | .34 | 0.55 | 9/16 | 2-011 |
| 3-3 T2HOA5 | 3M2TU3 | 3-TA-OR-ST | 3/16 | 3/8-24 | 1.38 | 0.56 | .38 | 0.62 | 5/8 | 2-012 |
| 4-4 T2HOA5 | 4M2TU4 | 4-TA-OR-ST | 1/4 | 7/16-20 | 1.55 | 0.63 | .41 | 0.74 | 3/4 | 2-111 |
| 5-5 T2HOA5 | 5M2TU5 | 5-TA-OR-ST | 5/16 | 1/2-20 | 1.64 | 0.66 | .44 | 0.86 | 7/8 | 2-112 |
| 6-6 T2HOA5 | 6M2TU6 | 6-TA-OR-ST | 3/8 | 9/16-18 | 1.70 | 0.69 | .47 | 0.93 | 15/16 | 2-113 |
| 8-8 T2HOA5 | 8M2TU8 | 8-TA-OR-ST | 1/2 | 3/4-16 | 1.95 | 0.91 | .47 | 1.12 | 1-1/8 | 2-116 |
| 10-10 T2HOA5 | 10M2TU10 | 10-TA-OR-ST | 5/8 | 7/8-14 | 2.12 | 0.97 | .47 | 1.30 | 1-3/8 | 2-212 |
| 12-12 T2HOA5 | 12M2TU12 | 12-TA-OR-ST | 3/4 | 1-1/16-12 | 2.16 | 0.97 | .56 | 1.49 | 1-1/2 | 2-215 |
| 16-16 T2HOA5 | 16M2TU16 | 16-TA-OR-ST | 1 | 1-5/16-12 | 2.47 | 1.22 | .56 | 1.74 | 1-3/4 | 2-219 |

NOTE: Add -Z6 for assembly of nuts and ferrules on the tube stub end.

Dimensions for reference only, subject to change.

Parts are supplied with nitrile o-rings as standard. For Fluorocarbon o-rings, add the suffix "-VO". Other o-rings available upon request.

Tube End to O-Ring Pipe Thread

For fractional tube

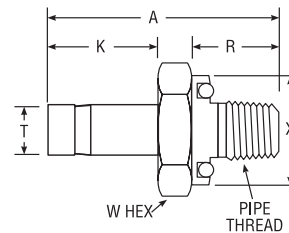
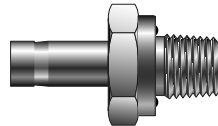

| CPI™ PART NO. | A-LOK® PART NO. | INTER- CHANGES WITH | INCHES | | | | | | | O-RING ARP UNIFORM DASH NO. |
|------------------|--------------------|---------------------------|-------------------|-----------------------|------|------|-----|-----------|----------|--------------------------------------|
| | | | T TUBE O.D. | NPT PIPE THREAD | A | K | R | X DIA. | W HEX | |
| 1-2 T2HOF5 | 1M3TU2 | 1-TA-1-2OR | 1/16 | 1/8 | 1.03 | 0.34 | .28 | 0.74 | 3/4 | 2-111 |
| 4-2 T2HOF5 | 4M3TU2 | 4-TA-1-2OR | 1/4 | 1/8 | 1.31 | 0.63 | .28 | 0.74 | 3/4 | 2-111 |
| 4-4 T2HOF5 | 4M3TU4 | 4-TA-1-4OR | 1/4 | 1/4 | 1.44 | 0.63 | .38 | 0.93 | 15/16 | 2-113 |
| 4-6 T2HOF5 | 4M3TU6 | 4-TA-1-6OR | 1/4 | 3/8 | 1.50 | 0.63 | .41 | 1.12 | 1-1/8 | 2-116 |
| 5-2 T2HOF5 | 5M3TU2 | 5-TA-1-2OR | 5/16 | 1/8 | 1.34 | 0.66 | .28 | 0.74 | 3/4 | 2-111 |
| 5-4 T2HOF5 | 5M3TU4 | 5-TA-1-4OR | 5/16 | 1/4 | 1.47 | 0.66 | .38 | 0.93 | 15/16 | 2-113 |
| 6-2 T2HOF5 | 6M3TU2 | 6-TA-1-2OR | 3/8 | 1/8 | 1.38 | 0.69 | .28 | 0.74 | 3/4 | 2-111 |
| 6-4 T2HOF5 | 6M3TU4 | 6-TA-1-4OR | 3/8 | 1/4 | 1.50 | 0.69 | .38 | 0.93 | 15/16 | 2-113 |
| 6-6 T2HOF5 | 6M3TU6 | 6-TA-1-6OR | 3/8 | 3/8 | 1.59 | 0.69 | .41 | 1.12 | 1-1/8 | 2-116 |
| 8-6 T2HOF5 | 8M3TU6 | 8-TA-1-6OR | 1/2 | 3/8 | 1.78 | 0.91 | .41 | 1.12 | 1-1/8 | 2-116 |
| 10-8 T2HOF5 | 10M3TU8 | 10-TA-1-8OR | 5/8 | 1/2 | 2.14 | 0.97 | .53 | 1.30 | 1-3/8 | 2-212 |
| 12-12 T2HOF5 | 12M3TU12 | 12-TA-1-12OR | 3/4 | 3/4 | 2.16 | 0.97 | .56 | 1.49 | 1-1/2 | 2-215 |
| 16-16 T2HOF5 | 16M3TU16 | 16-TA-1-16OR | 1 | 1 | 2.56 | 1.22 | .66 | 1.65 | 1-3/4 | 2-219 |

NOTE: Add -Z6 for assembly of nuts and ferrules on the tube stub end.

Dimensions for reference only, subject to change.

Parts are supplied with nitrile o-rings as standard. For Fluorocarbon o-rings, add the suffix "-VO". Other o-rings available upon request.

Color Coding

For easy reference, table column headings are color indicated as follows:

fractional



metric



NPT Thread to SAE Straight Thread Adapter For fractional tube

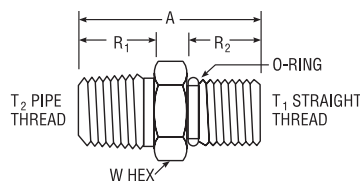
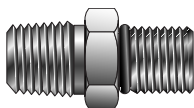

| CPI™ PART NO. | A-LOK® PART NO. | INTER- CHANGES WITH | INCHES | | | | | | O-RING AS UNIFORM DASH NO. |
|------------------|--------------------|---------------------------|---------------------------------|--|------|-----|-----|----------|-------------------------------------|
| | | | T ₂ NPT THREAD | T ₁ SAE STRAIGHT THREAD | A | R1 | R2 | W HEX | |
| 4-4 FHOA | 4-4 FHOA | 4-SAE-1-4 | 1/4-18 | 7/16-20 | 1.20 | .56 | .36 | 9/16 | 3-904 |
| 6-6 FHOA | 6-6 FHOA | 6-SAE-1-6 | 3/8-18 | 9/16-18 | 1.26 | .56 | .39 | 11/16 | 3-906 |
| 8-8 FHOA | 8-8 FHOA | 8-SAE-1-8 | 1/2-14 | 3/4-16 | 1.53 | .75 | .44 | 7/8 | 3-908 |
| 12-12 FHOA | 12-12 FHOA | 12-SAE-1-12 | 3/4-14 | 1-1/16-12 | 1.75 | .75 | .59 | 1-1/4 | 3-912 |
| 16-16 FHOA | 16-16 FHOA | 16-SAE-1-16 | 1-11-1/2 | 1-5/16-12 | 2.00 | .94 | .59 | 1-1/2 | 3-916 |

NOTE: A and C dimensions are typical finger-tight.

Dimensions for reference only, subject to change.

For use with SAE J.1926/1 port can also be used with MS-16142 port.
Parts are supplied with nitrile o-rings as standard. For Fluorocarbon o-rings, add the suffix "-VO".
Other o-rings available upon request.

Bulkhead to Conversion Adapter For fractional tube

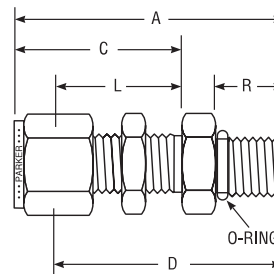
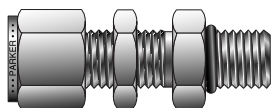

| CPI™ PART NO. | A-LOK® PART NO. | INTER- CHANGES WITH | INCHES | | | | | | | | | |
|------------------|--------------------|---------------------------|--------------|----------------------------|------|------|------|-----|-----|----------|--------------------------------|----------------------------------|
| | | | TUBE O.D. | STRAIGHT THREAD SIZE | A | C | D | R | L | W HEX | BULKHEAD HOLE DRILL SIZE | MAXIMUM BULKHEAD THICKNESS |
| 4-6 AH2BZ | 4-6 AH2LZ | 400-11-6ST | 1/4 | 9/16-18 | 1.74 | 1.17 | 1.45 | .39 | .88 | 3/4 | 37/64 | 9/16 |
| 6-6 AH2BZ | 6-6 AH2LZ | 600-11-6ST | 3/8 | 9/16-18 | 1.81 | 1.24 | 1.52 | .39 | .94 | 3/4 | 37/64 | 9/16 |

NOTE: A and C dimensions are typical finger-tight.

Dimensions for reference only, subject to change.

For use with SAE J.1926/1 port can also be used with MS-16142 port.
Parts are supplied with nitrile o-rings as standard. For Fluorocarbon o-rings, add the suffix "-VO".
Other o-rings available upon request.

Color Coding

For easy reference, table column headings are color indicated as follows:

fractional



metric



General

The weld used in joining a tube to a socket weld tube fitting is like any other type of “tee” weld. The root (i.e., the point of intersection of the outside of the tube and annular end area of the fitting) must be included in the weld zone.

Careful welding procedures are normally followed to assure that this root area is included in the weld. If penetration is not achieved, the joint will have two built-in stress risers which may greatly reduce the strength of the weld. Upon application of an extreme load, these stress risers could result in cracks which could propagate out through the weld or tube depending upon the direction of the greatest load.

Often to achieve full root penetration in TIG welding of stainless steels, a fusion pass will be made first, followed by a final pass utilizing a filler rod to achieve the desired fillet size.

Assembly

The codes applicable to the welding of socket weld fittings require that the tube be inserted into the socket until bottomed against the stop. The tube is then to be backed out approximately 1/16 of an inch and then welded.

If the tube is not backed out, but welded when against a flat bottom stop, the contraction of the weld fillet and fitting socket can combine to produce a static stress on the weld. During thermal transients, the fitting and the portion of the tube within the fitting may experience a differential rate of heating or cooling, again adding to the stress level in the weld.

Tacking

If the weld joint is to be “tacked” before welding, it is recommended that the “Tack” weld build-up be held to a minimum.

Excessive build-up on the “tack” may cause an interrupted final bead and a stress riser or lack of complete fusion.

Backing Gas

Backing gas is an inert gas used to flood the interior of the fittings and tube system during welding. It serves the same purpose internally as the shielding gas used in TIG or MIG welding. By reducing the interior oxygen level to as low as practicable, it also serves to control the combustion of contaminants that could affect weld quality.

When a backing gas is not used and nearly 100% weld penetration is achieved, blisters will tend to form on the internal tube wall. This will result in scale which may later break loose. Therefore, in 0.050 wall or thinner tube or where the wall thickness is such that the selected weld process may burn through, the use of a backing gas is mandatory.

In most cases the backing gas will be argon or helium connected to the system through a control regulator. Flow rates, while small, should be high enough to purge the system. Welds should be made in downstream sequence from the gas connection.

Note that the entire system should be purged to insure that there are no openings that will allow air to be drawn into the system.

The use of backing gas, while often not mandatory, will give a better weld joint. This is because the effects of contaminate combustion by-products are eliminated and because the welds are made and cooled under a shielded atmosphere, thus eliminating internal scaling or blistering.

Welding Methods

300 Series Stainless Steels

May be welded by the TIG, MIG, or stick arc-weld process.

TIG welding is recommended as being best for welding Weld-lok® systems because it allows better operator control of heat penetration and filler material deposition.

Stick arc welding is not recommended in many cases because of the likelihood of excessive burn-through and improper root penetration. In all cases where stick welding is used, it is recommended that backing gas be used.

MIG welding gives the same characteristics as stick electrode welding with faster deposition of the filler material. As this process runs “hotter” than the stick process, the use of a backing gas is mandatory. It should be noted that in welding the relatively small fitting sizes found in the Weld-lok® line, filler deposition rate economies are not a factor and therefore the MIG method is not commonly applied.

C1018 Steel Fittings

May be welded by the TIG, MIG, stick and oxyacetylene methods. As scale formation remains a problem, the use of a backing gas is still recommended.

Carbide Precipitation

When unstabilized stainless steels are heated to 800°–1500°F during welding, the chromium in the steel combines with the carbon to form chrome carbides which tend to form along the grain boundaries of the metal (carbide precipitation). This lowers the dissolved chromium content in these areas and thus lowers their corrosion resistance, making them vulnerable to intergranular corrosion. Carbide precipitation is reduced by holding the carbon content of the material to a very low value. This limits the amount of carbon available to combine with the chromium. The “L” series (extra low carbon) stainless steels are often used for this purpose, but their use reduces system design stress by approximately 15%. Parker Weld-lok® fittings are made from a select 316 series with carbon content in the low range of 0.04 to 0.07 percent. This results in a welded fitting with good corrosion resistance and a high strength factor.

All Parker Weld-lok® fittings in stainless steel are supplied in the solution treated condition, capable of passing ASTM-A-262 Tests for Detecting Susceptibility to Intergranular Corrosion.

Arc Polarity

When welding Weld-lok® fittings, best results will be obtained by the following arc polarities:

- TIG – Direct Current, straight polarity
- MIG – Direct Current, reverse polarity
- STICK – Polarity dependent on rod used

For further information on Parker’s Welded Fittings refer to Parker’s Welded Fittings Catalog 4280 or contact Parker’s Instrumentation Products Division – Product Engineering at 256-881-2040.

Socket Weld Elbow

For fractional tube

- for CPI™/A-LOK® to tubing socket weld connection

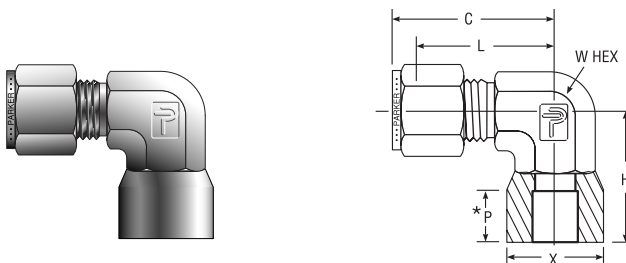

| CPI™ PART NO. | A-LOK® PART NO. | INTER- CHANGES WITH | INCHES | | | | | | |
|------------------|--------------------|---------------------------|--------------|------|------|------|-----|------|----------|
| | | | TUBE O.D. | C | L | H | P* | X | W HEX |
| 2-2 ZEBW | 2-2 ZELW | 200-9-2 W | 1/8 | 0.92 | 0.66 | 0.63 | .16 | .38 | 5/16 |
| 3-3 ZEBW | 3-3 ZELW | 300-9-3 W | 3/16 | 0.98 | 0.72 | 0.69 | .20 | .44 | 7/16 |
| 4-4 ZEBW | 4-4 ZELW | 400-9-4 W | 1/4 | 1.06 | 0.78 | 0.84 | .25 | .50 | 9/16 |
| 6-6 ZEBW | 6-6 ZELW | 600-9-6 W | 3/8 | 1.31 | 1.02 | 1.08 | .34 | .63 | 3/4 |
| 8-8 ZEBW | 8-8 ZELW | 810-9-8 W | 1/2 | 1.42 | 1.02 | 1.14 | .41 | .76 | 3/4 |
| 10-10 ZEBW | 10-10 ZELW | 1010-9-10 W | 5/8 | 1.57 | 1.17 | 1.35 | .49 | .94 | 1-1/16 |
| 12-12 ZEBW | 12-12 ZELW | 1210-9-12 W | 3/4 | 1.57 | 1.17 | 1.39 | .50 | 1.09 | 1-1/16 |
| 16-16 ZEBW | 16-16 ZELW | 1610-9-16 W | 1 | 1.93 | 1.65 | 1.84 | .56 | 1.38 | 1-5/8 |

NOTE: C dimension is typical finger-tight.

Dimensions for reference only, subject to change.

*Socket Depth

Buttweld Elbow

For fractional tube

- for CPI™/A-LOK® to pipe buttweld connection

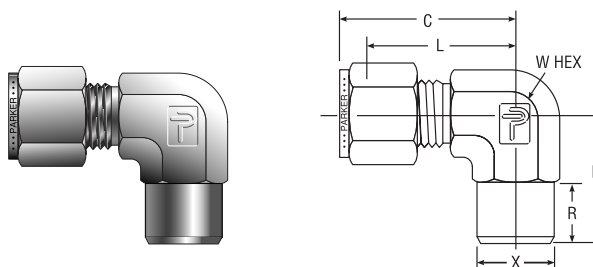

| CPI™ PART NO. | A-LOK® PART NO. | INTER- CHANGES WITH | INCHES | | | | | | | |
|------------------|--------------------|---------------------------|--------------|--------------------------|------|------|------|-----|-----------------------|----------|
| | | | TUBE O.D. | BUTTWELD PIPE SIZE | C | H | L | R | X BUTTWELD O.D. | W HEX |
| 2-1/8 ZEBW2 | 2-1/8 ZELW2 | 200-2-2 W | 1/8 | 1/8 | 0.93 | 0.70 | 0.67 | .38 | .405 | 7/16 |
| 3-1/8 ZEBW2 | 3-1/8 ZELW2 | 300-2-2 W | 3/16 | 1/8 | 1.01 | 0.74 | 0.74 | .38 | .405 | 7/16 |
| 4-1/8 ZEBW2 | 4-1/8 ZELW2 | 400-2-2 W | 1/4 | 1/8 | 1.06 | 0.74 | 0.77 | .38 | .405 | 7/16 |
| 4-1/4 ZEBW2 | 4-1/4 ZELW2 | 400-2-4 W | 1/4 | 1/4 | 1.10 | 0.97 | 0.78 | .56 | .540 | 9/16 |
| 6-1/4 ZEBW2 | 6-1/4 ZELW2 | 600-2-4 W | 3/8 | 1/4 | 1.20 | 1.00 | 0.91 | .56 | .540 | 5/8 |
| 8-3/8 ZEBW2 | 8-3/8 ZELW2 | 810-2-6 W | 1/2 | 3/8 | 1.42 | 1.11 | 1.02 | .56 | .675 | 13/16 |
| 8-1/2 ZEBW2 | 8-1/2 ZELW2 | 810-2-8 W | 1/2 | 1/2 | 1.42 | 1.30 | 1.02 | .75 | .840 | 7/8 |
| 10-1/2 ZEBW2 | 10-1/2 ZELW2 | 1010-2-8 W | 5/8 | 1/2 | 1.50 | 1.39 | 1.10 | .75 | .840 | 15/16 |
| 12-3/4 ZEBW2 | 12-3/4 ZELW2 | 1210-2-12 W | 3/4 | 3/4 | 1.57 | 1.45 | 1.17 | .75 | 1.050 | 1-1/16 |
| 16-3/4 ZEBW2 | 16-3/4 ZELW2 | 1610-2-12 W | 1 | 3/4 | 1.94 | 1.64 | 1.45 | .75 | 1.050 | 1-3/8 |
| 16-1 ZEBW2 | 16-1 ZELW2 | 1610-2-16 W | 1 | 1 | 1.94 | 1.84 | 1.45 | .94 | 1.315 | 1-5/16 |

NOTE: C dimension is typical finger-tight.

Dimensions for reference only, subject to change.

Pipe buttweld end will conform to Schedule 80 unless otherwise noted.

Color Coding

For easy reference, table column headings are color indicated as follows:

fractional



metric



Socket Weld Connector

For fractional tube

- for CPI™ / A-LOK® to tubing socket weld connection

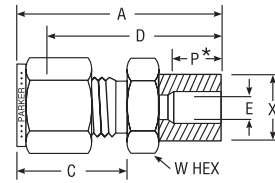
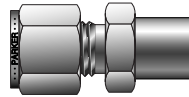

| CPI™ PART NO. | A-LOK® PART NO. | INTER- CHANGES WITH | INCHES | | | | | | | |
|------------------|--------------------|---------------------------|--------------|------|------|------|-----|------|-----------|----------|
| | | | TUBE O.D. | A | C | D | P* | X | E BORE | W HEX |
| 2-2 ZHBW | 2-2 ZHLW | 200-6-2 W | 1/8 | 1.16 | 0.60 | 0.90 | .16 | 0.38 | .094 | 7/16 |
| 3-3 ZHBW | 3-3 ZHLW | 300-6-3 W | 3/16 | 1.24 | 0.64 | 0.98 | .20 | 0.44 | .141 | 1/2 |
| 4-4 ZHBW | 4-4 ZHLW | 400-6-4 W | 1/4 | 1.36 | 0.70 | 1.07 | .25 | 0.50 | .188 | 9/16 |
| 6-6 ZHBW | 6-6 ZHLW | 600-6-6 W | 3/8 | 1.53 | 0.76 | 1.24 | .34 | 0.63 | .313 | 11/16 |
| 8-8 ZHBW | 8-8 ZHLW | 810-6-8 W | 1/2 | 1.74 | 0.87 | 1.34 | .41 | 0.78 | .438 | 13/16 |
| 10-10 ZHBW | 10-10 ZHLW | 1010-6-10 W | 5/8 | 1.86 | 0.87 | 1.46 | .47 | 0.94 | .500 | 1 |
| 12-12 ZHBW | 12-12 ZHLW | 1210-6-12 W | 3/4 | 1.92 | 0.87 | 1.52 | .50 | 1.09 | .656 | 1-1/8 |
| 16-16 ZHBW | 16-16 ZHLW | 1610-6-16 W | 1 | 2.31 | 1.05 | 1.82 | .56 | 1.44 | .906 | 1-5/8 |

NOTE: A and C dimensions are typical finger-tight.

Dimensions for reference only, subject to change.

See Catalog 4280, Welded Fittings, for additional sizes.

*Socket Depth

Butt Weld Connector

For fractional tube

- for CPI™ / A-LOK® to pipe butt weld connection

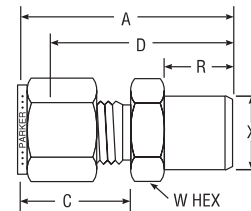
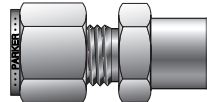

| CPI™ PART NO. | A-LOK® PART NO. | INTER- CHANGES WITH | INCHES | | | | | | | |
|------------------|--------------------|---------------------------|--------------|---------------------------|------|------|------|-----|------------------------|----------|
| | | | TUBE O.D. | BUTT WELD PIPE SIZE | A | C | D | R | X BUTT WELD O.D. | W HEX |
| 2-1/8 ZHBW2 | 2-1/8 ZHLW2 | 200-1-2 W | 1/8 | 1/8 | 1.20 | 0.60 | 0.94 | .38 | .405 | 7/16 |
| 3-1/8 ZHBW2 | 3-1/8 ZHLW2 | 300-1-2 W | 3/16 | 1/8 | 1.24 | 0.64 | 0.97 | .38 | .405 | 7/16 |
| 4-1/8 ZHBW2 | 4-1/8 ZHLW2 | 400-1-2 W | 1/4 | 1/8 | 1.29 | 0.70 | 1.00 | .38 | .405 | 1/2 |
| 4-1/4 ZHBW2 | 4-1/4 ZHLW2 | 400-1-4 W | 1/4 | 1/4 | 1.46 | 0.70 | 1.17 | .56 | .540 | 9/16 |
| 5-1/8 ZHBW2 | 5-1/8 ZHLW2 | 500-1-2 W | 5/16 | 1/8 | 1.48 | 0.73 | 1.22 | .38 | .405 | 1/2 |
| 5-1/4 ZHBW2 | 5-1/4 ZHLW2 | 500-1-4 W | 5/16 | 1/4 | 1.49 | 0.76 | 1.23 | .56 | .540 | 9/16 |
| 6-1/4 ZHBW2 | 6-1/4 ZHLW2 | 600-1-4 W | 3/8 | 1/4 | 1.49 | 0.76 | 1.20 | .56 | .540 | 9/16 |
| 6-3/8 ZHBW2 | 6-3/8 ZHLW2 | 600-1-6 W | 3/8 | 3/8 | 1.60 | 0.76 | 1.31 | .56 | .675 | 3/4 |
| 6-1/2 ZHBW2 | 6-1/2 ZHLW2 | 600-1-8 W | 3/8 | 1/2 | 1.82 | 0.76 | 1.53 | .75 | .840 | 7/8 |
| 6-3/4 ZHBW2 | 6-3/4 ZHLW2 | 600-1-12 W | 3/8 | 3/4 | 1.88 | 0.76 | 1.59 | .75 | 1.050 | 1-1/8 |
| 8-3/8 ZHBW2 | 8-3/8 ZHLW2 | 810-1-6 W | 1/2 | 3/8 | 1.71 | 0.87 | 1.31 | .56 | .675 | 13/16 |
| 8-1/2 ZHBW2 | 8-1/2 ZHLW2 | 810-1-8 W | 1/2 | 1/2 | 1.93 | 0.87 | 1.53 | .75 | .840 | 7/8 |
| 8-3/4 ZHBW2 | 8-3/4 ZHLW2 | 810-1-12 W | 1/2 | 3/4 | 1.99 | 0.87 | 1.59 | .75 | 1.050 | 1-1/8 |
| 10-1/2 ZHBW2 | 10-1/2 ZHLW2 | 1010-1-8 W | 5/8 | 1/2 | 1.93 | 0.87 | 1.53 | .75 | .840 | 15/16 |
| 12-3/4 ZHBW2 | 12-3/4 ZHLW2 | 1210-1-12 W | 3/4 | 3/4 | 1.99 | 0.87 | 1.59 | .75 | 1.050 | 7/8 |
| 16-1 ZHBW2 | 16-1 ZHLW2 | 1610-1-16 W | 1 | 1 | 2.46 | 1.05 | 1.97 | .94 | 1.310 | 1-1/16 |

NOTE: A and C dimensions are typical finger-tight.

Dimensions for reference only, subject to change.

Pipe Butt weld end will conform to Schedule 80 unless otherwise noted.

See Catalog 4280, Welded Fittings, for additional sizes.

Butt Weld Connector

For metric tube

- for CPI™/A-LOK® to pipe butt weld connection

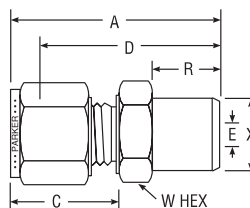
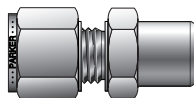

| CPI™ PART NO. | A-LOK® PART NO. | INTER- CHANGES WITH | MILLIMETERS | | | | | | | | |
|------------------|--------------------|---------------------------|--------------|---------------------------|------|------|------|------|------|-----------|----------|
| | | | TUBE O.D. | BUTT WELD PIPE N.B. | A | C | D | R | X | E BORE | W HEX |
| ZHBW2 3-1/8 | ZHLW2 3-1/8 | 3MO-1-2W | 3 | 1/8 | 29,7 | 15,3 | 23,1 | 9,7 | 10,3 | 2,4* | 12,0 |
| ZHBW2 4-1/8 | ZHLW2 4-1/8 | 4MO-1-2 | 4 | 1/8 | 30,7 | 16,1 | 24,1 | 9,7 | 10,3 | 2,4* | 12,0 |
| ZHBW2 6-1/8 | ZHLW2 6-1/8 | 6MO-1-2 | 6 | 1/8 | 32,9 | 17,7 | 25,4 | 9,7 | 10,3 | 4,8 | 14,0 |
| ZHBW2 6-1/4 | ZHLW2 6-1/4 | 6MO-1-4W | 6 | 1/4 | 37,7 | 17,7 | 30,2 | 14,2 | 13,7 | 4,8* | 14,0 |
| ZHBW2 8-1/8 | ZHLW2 8-1/8 | 8MO-1-2 | 8 | 1/8 | 34,2 | 18,6 | 26,7 | 9,7 | 10,3 | 5,1 | 15,0 |
| ZHBW2 8-1/4 | ZHLW2 8-1/4 | 8MO-1-1/4 | 8 | 1/4 | 38,7 | 18,6 | 31,2 | 14,2 | 13,7 | 6,4 | 15,0 |
| ZHBW2 8-1/2 | ZHLW2 8-1/2 | 8MO-1-8 | 8 | 1/2 | 44,8 | 18,6 | 37,3 | 19,1 | 21,3 | 6,4* | 22,0 |
| ZHBW2 10-1/4 | ZHLW2 10-1/4 | – | 10 | 1/4 | 40,9 | 19,5 | 33,3 | 14,2 | 13,7 | 7,1 | 18,0 |
| ZHBW2 10-3/8 | ZHLW2 10-3/8 | 10MO-1-6 | 10 | 3/8 | 40,1 | 19,5 | 32,5 | 14,2 | 17,2 | 7,9* | 18,0 |
| ZHBW2 10-1/2 | ZHLW2 10-1/2 | – | 10 | 1/2 | 45,7 | 19,5 | 38,1 | 19,1 | 21,3 | 7,9* | 22,0 |
| ZHBW2 12-1/4 | ZHLW2 12-1/4 | – | 12 | 1/4 | 43,4 | 22,0 | 33,3 | 14,2 | 13,7 | 7,1 | 22,0 |
| ZHBW2 12-3/8 | ZHLW2 12-3/8 | – | 12 | 3/8 | 43,4 | 22,0 | 33,3 | 14,2 | 17,2 | 9,5 | 22,0 |
| ZHBW2 12-1/2 | ZHLW2 12-1/2 | 12MO-1-8W | 12 | 1/2 | 48,2 | 22,0 | 38,1 | 19,1 | 21,3 | 9,5* | 22,0 |
| ZHBW2 15-1/2 | ZHLW2 15-1/2 | – | – | 1/2 | 48,2 | 22,0 | 38,9 | 19,1 | 21,3 | 9,5* | 24,0 |
| ZHBW2 16-1/2 | ZHLW2 16-1/2 | – | 16 | 1/2 | 49,0 | 22,0 | 38,9 | 19,1 | 21,3 | 12,7* | 24,0 |
| ZHBW2 18-1/2 | ZHLW2 18-1/2 | – | 18 | 1/2 | 50,5 | 22,0 | 40,4 | 19,1 | 21,3 | 13,5 | 27,0 |

NOTE: *E dimension is minimum opening.
 Fittings of this group may be back-drilled to larger I.D. at pipe end.
 A and C dimensions are typical finger-tight.
 Pipe Butt weld end will conform to Schedule 80 unless otherwise noted.

Dimensions for reference only, subject to change.

Color Coding

For easy reference, table column headings are color indicated as follows:

fractional



metric



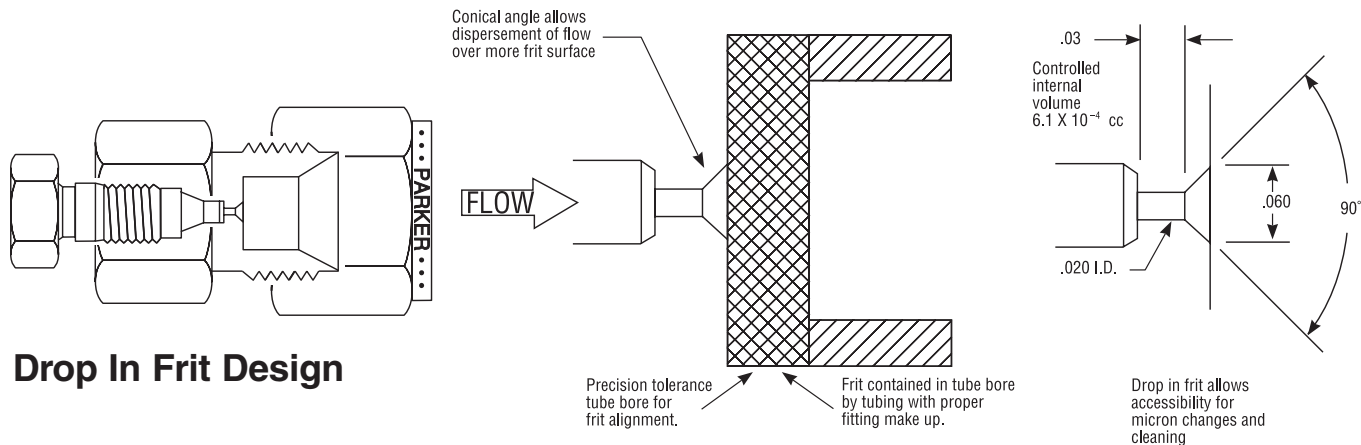

Drop In Frit Design

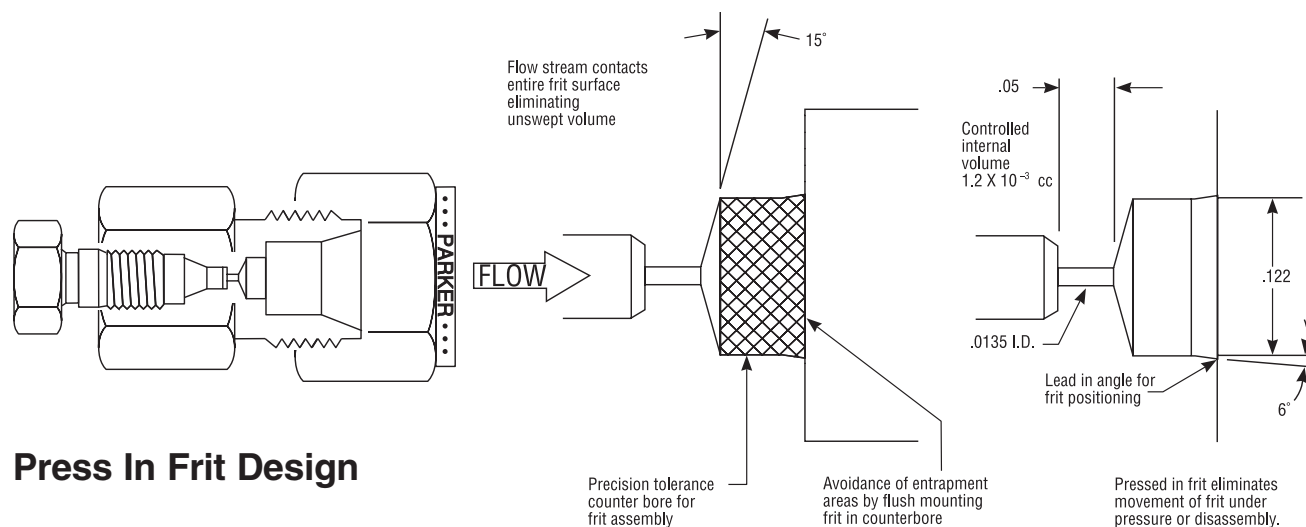

Press In Frit Design

Parker Hannifin's Instrumentation Products Division offers a full line of analytical tube fittings. These fittings range from elbows, tees, and male connectors to low dead volume unions and column end fittings. Parker incorporates various features in the column end fittings to effectively address various industry concerns.

- Peak symmetry for critical analysis
- Internal volume reduction

As the observed media/substance migrates through the HPLC column, a "peak" or "band" is created that denotes the level of concentration. It is critical to maintain peak symmetry in order to get an accurate reading when processing the observed media/substance. Parker Hannifin, in the development of a line of column end fittings, has incorporated some key features that help to maintain this "peak symmetry" in HPLC columns.

"Under most circumstances in liquid chromatography (LC), the flow through the tube is laminar, the so-called Poiseuille flow, and in this situation the velocity at all points is parallel to the tube axis."

Due to the importance of maintaining smooth laminar flow after injection of the sample into the HPLC column, Parker

incorporated a small conical angle on the fitting body internals. This conical angle helps to equally disperse the sample into the column tube. One of the key requirements of an effective column end fitting is not to delay or disturb the flow of the sample through the instrument (HPLC column).

A second area to address is the minimizing of tube fitting internal "cavities". A cavity is a short section of the flow path where the flow-channel diameter increases. It can occur where tubes are connected to each other (low dead volume connector) or to injectors, columns (column end fittings), and detectors. Large cavities can seriously degrade the resolution of any chromatogram, but they can be easily avoided through awareness of the geometric design details of the fittings and connecting parts manufactured by various companies.

Parker Hannifin has incorporated those critical features in both a low dead volume union connector and the column end fitting bodies. First, the utilization of inverted 1/16" connections to greatly reduce internal volume or cavities. To eliminate any confusion or occurrence of incorrect effective tube make-up, the port depths (body bore dimensions) are identical by size throughout the entire Parker Hannifin instrumentation line. Second, Parker closely monitors the dimensions of the small through-hole utilized in these low dead volume connectors.



Column End Fitting – Low Internal Volume with Frit

For fractional tube

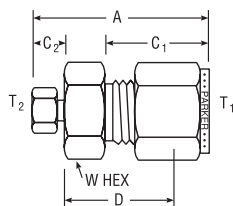
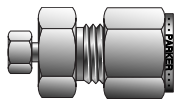

| CPI™ PART NO. | A-LOK® PART NO. | INCHES | | | | | | | INTERNAL VOLUME |
|---------------|-----------------|--------------------------|--------------------------|------|-----|-----|-------|------------------|-----------------|
| | | T ₁ TUBE O.D. | T ₂ TUBE O.D. | A | C | D | W HEX | INTERNAL OPENING | |
| 2-1 Z2HCZ7 | 2-1 Z2HLZ7 | 1/8 | 1/16 | 1.25 | .60 | .78 | 7/16 | .013 | 5.4 x 10-4cc |
| 4-1 Z2HCZ7 | 4-1 Z2HLZ7 | 1/4 | 1/16 | 1.35 | .70 | .84 | 1/2 | .013 | 1.2 x 10-3cc |
| 6-1 Z2HCZ7 | 6-1 Z2HLZ7 | 3/8 | 1/16 | 1.43 | .76 | .92 | 5/8 | .013 | 3.8 x 10-3cc |

NOTE: A and C dimensions are typical finger-tight.

Dimensions for reference only, subject to change.

| FRIT DESIGNATOR | |
|-------------------|-------------|
| * MICRON DASH NO. | MICRON SIZE |
| -1 | 0.5 μ |
| -2 | 2 μ |
| -3 | 5 μ |
| -4 | 10 |

| HOW TO ORDER |
|--|
| EXAMPLE: 4-1Z2HLZ7-2*-SS To order with 2μ frit for 1/4" O.D. column |

Features:

- Inverted 1/16" end substantially reduces internal volume
- Flow stream contacts entire frit surface reducing plugging and eliminating unswept volume
- Can be used as a low volume final filter

Column End Fitting – Low Internal Volume

For fractional tube

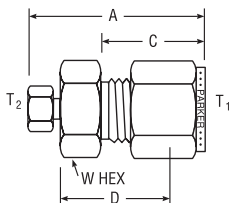
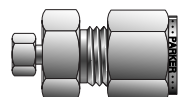

| CPI™ PART NO. | A-LOK® PART NO. | INCHES | | | | | | | INTERNAL VOLUME |
|---------------|-----------------|--------------------------|--------------------------|------|------|------|-------|------------------|-----------------|
| | | T ₁ TUBE O.D. | T ₂ TUBE O.D. | A | C | D | W HEX | INTERNAL OPENING | |
| 4-1 Z3HCZ7 | 4-1 Z3HLZ7 | 1/4 | 1/16 | 1.28 | 0.70 | 0.77 | 1/2 | .020 | 6.1 x 10-4cc |
| 6-1 Z3HCZ7 | 6-1 Z3HLZ7 | 3/8 | 1/16 | 1.37 | 0.76 | 0.86 | 5/8 | .020 | 8.1 x 10-4cc |
| 8-1 Z3HCZ7 | 8-1 Z3HLZ7 | 1/2 | 1/16 | 1.62 | 0.87 | 1.00 | 13/16 | .030 | 2.8 x 10-3cc |
| 16-1 Z3HCZ7 | 16-1 Z3HLZ7 | 1 | 1/16 | 2.00 | 1.05 | 1.31 | 1-3/8 | .030 | 2 x 10-2cc |

NOTE: A and C dimensions are typical finger-tight.

Dimensions for reference only, subject to change.

Features:

- Inverted 1/16" end substantially reduces internal volume
- Drop in frit for use with L.C.* columns or G.C.* columns
- Conical angle below frit directs flow over more frit surface
- Available for up to 1" columns

*G.C. = Gas Chromatograph
L.C. = Liquid Chromatograph

Di-Frit (drop in)

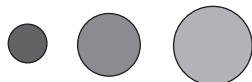

Replaceable frit for preparatory column end fitting Z3HLZ7. Frits are available in 2, 5 and 10 micron sizes.

| CPI™/A-LOK® PARKER PART NO. | MICRON SIZE | COLUMN O.D. |
|-----------------------------|-------------|-------------|
| 4 DI FRIT-5MIC-SS | 5 | 1/4" |
| 4 DI FRIT-10MIC-SS | 10 | 1/4" |
| 6 DI FRIT-2MIC-SS | 2 | 3/8" |
| 6 DI FRIT-5MIC-SS | 5 | 3/8" |
| 6 DI FRIT-10MIC-SS | 10 | 3/8" |

| PARKER PART NO. | MICRON SIZE | COLUMN O.D. |
|---------------------|-------------|-------------|
| 8 DI FRIT-5MIC-SS | 5 | 1/2" |
| 8 DI FRIT-10MIC-SS | 10 | 1/2" |
| 16 DI FRIT-2MIC-SS | 2 | 1" |
| 16 DI FRIT-5MIC-SS | 5 | 1" |
| 16 DI FRIT-10MIC-SS | 10 | 1" |

Color Coding

For easy reference, table column headings are color indicated as follows:

fractional



metric



Column End Fitting – Low Internal Volume (without Frit) For fractional tube

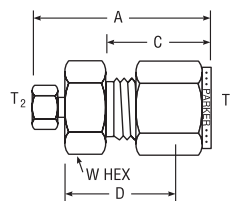
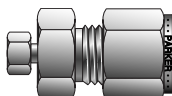

| CPI™ PART NO. | A-LOK® PART NO. | INTER- CHANGES WITH | INCHES | | | | | | | INTERNAL OPENING | INTERNAL VOLUME |
|------------------|--------------------|---------------------------|---------------------------------|---------------------------------|------|-----|-----|----------|------|---------------------------|--------------------|
| | | | T ₁ TUBE O. D. | T ₂ TUBE O. D. | A | C | D | W HEX | | | |
| 2-1 ZHCZ7 | 2-1 ZHLZ7 | -200-6-1-FGC | 1/8 | 1/16 | 1.16 | .60 | .70 | 7/16 | .013 | 1.0 x 10 ⁻⁴ cc | |
| 4-1 ZHCZ7 | 4-1 ZHLZ7 | -400-6-1-FGC | 1/4 | 1/16 | 1.24 | .70 | .77 | 1/2 | .013 | 1.1 x 10 ⁻⁴ cc | |
| 6-1 ZHCZ7 | 6-1 ZHLZ7 | -600-6-1-FGC | 3/8 | 1/16 | 1.35 | .76 | .86 | 5/8 | .013 | 1.3 x 10 ⁻⁴ cc | |

NOTE: A and C dimensions are typical finger-tight.

Dimensions for reference only, subject to change.

Features:

- Inverted 1/16" end substantially
- No frit for use with G.C.* columns or L.C.* columns with screens
- Can be used as a low volume reducing union

*G.C. = Gas Chromatograph
L.C. = Liquid Chromatograph

Column End Fitting – with Frit For fractional tube

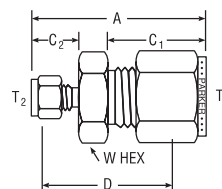
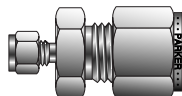

| CPI™ PART NO. | A-LOK® PART NO. | T ₁ TUBE O. D. | T ₂ TUBE O. D. | INCHES | | | | W HEX | INTERNAL OPENING | INTERNAL VOLUME |
|------------------|--------------------|---------------------------------|---------------------------------|--------|-----|-----|------|----------|---------------------|---------------------------|
| | | | | A | C1 | C2 | D | | | |
| 2-1 Z2HCZ | 2-1 Z2HLZ | 1/8 | 1/16 | 1.21 | .60 | .43 | .81 | 7/16 | .020 | 2.1 x 10 ⁻³ cc |
| 4-1 Z2HCZ | 4-1 Z2HLZ | 1/4 | 1/16 | 1.35 | .70 | .43 | .91 | 1/2 | .020 | 1.8 x 10 ⁻³ cc |
| 6-1 Z2HCZ | 6-1 Z2HLZ | 3/8 | 1/16 | 1.44 | .76 | .43 | 1.00 | 5/8 | .020 | 5.4 x 10 ⁻³ cc |

NOTE: A and C dimensions are typical finger-tight.

Dimensions for reference only, subject to change.

| FRIT DESIGNATOR | |
|-------------------|-------------|
| * MICRON DASH NO. | MICRON SIZE |
| -1 | 0.5μ |
| -2 | 2.0μ |
| -3 | 5.0μ |
| -4 | 10.0μ |

| HOW TO ORDER |
|---|
| EXAMPLE: 4-1Z2HLZ-2*-SS To order with 2μ frit for 1/4" O.D. column |

NOTE: Size 1 not silver-plated.

Features:

- Flow stream contacts entire frit surface reducing plugging and eliminating unswept volume
- Can be used as a low volume final filter with drop-in frit

Column End Fitting – (without Frit) For fractional tube

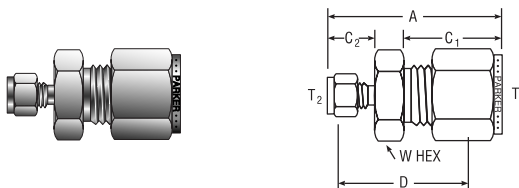

| CPI™ PART NO. | A-LOK® PART NO. | INTER- CHANGES WITH | INCHES | | | | | | | | INTERNAL OPENING | INTERNAL VOLUME |
|------------------|--------------------|---------------------------|---------------------------------|---------------------------------|------|----------------|----------------|------|----------|------|---------------------|--------------------|
| | | | T ₁ TUBE O. D. | T ₂ TUBE O. D. | A | C ₁ | C ₂ | D | W HEX | | | |
| 2-1 ZHCZ | 2-1 ZHLZ | 200-6-1LV | 1/8 | 1/16 | 1.21 | .60 | .43 | 0.81 | 7/16 | .020 | 2.1 x 10-3cc | |
| 4-1 ZHCZ | 4-1 ZHLZ | 400-6-1LV | 1/4 | 1/16 | 1.35 | .70 | .43 | 0.91 | 1/2 | .020 | 2.1 x 10-3cc | |
| 6-1 ZHCZ | 6-1 ZHLZ | 600-6-1LV | 3/8 | 1/16 | 1.44 | .76 | .43 | 1.00 | 5/8 | .020 | 2.3 x 10-3cc | |

NOTE: A and C dimensions are typical finger-tight.

Dimensions for reference only, subject to change.

Size 1 Nut is not silver plated

Union Connector – Low Dead Volume For fractional tube

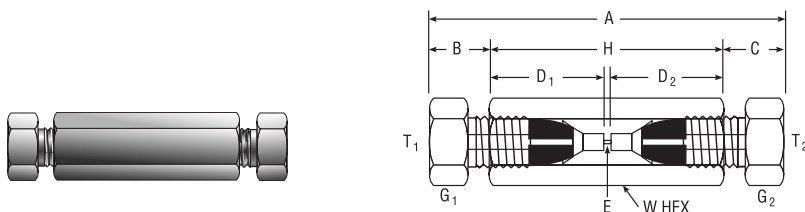

| CPI™ PART NO. | A-LOK® PART NO. | INTER- CHANGES WITH | INCHES | | | | | | | | | | | INTERNAL VOLUME | |
|------------------|--------------------|---------------------------|---------------------------------|---------------------------------|------|-----|-----|----------------|----------------|--------------------------|----------------|----------------|------|--------------------|--------------|
| | | | T ₁ TUBE O. D. | T ₂ TUBE O. D. | †A | †B | †C | D ₁ | D ₂ | E INTERNAL OPENING | G ₁ | G ₂ | H | | W HEX |
| 1-1 Z7HBZ7-SS | 1-1 Z7HLZ7 | IFO-6GC | 1/16 | 1/16 | 1.26 | .21 | .21 | .41 | .41 | .013 | .25 | .25 | .84 | 1/4 | 8.7 x 10-5cc |
| 2-1 Z7HBZ7-SS | 2-1 Z7HLZ7 | – | 1/8 | 1/16 | 1.53 | .31 | .21 | .56 | .41 | .013 | .38 | .25 | 1.02 | 7/16 | 8.7 x 10-5cc |
| 2-2 Z7HBZ7-SS | 2-2 Z7HLZ7 | – | 1/8 | 1/8 | 1.81 | .31 | .31 | .56 | .56 | .052 | .38 | .38 | 1.19 | 7/16 | 9.7 x 10-2cc |

†Average Value

Dimensions for reference only, subject to change.

Color Coding

For easy reference, table column headings are color indicated as follows:

fractional



metric



Male Connector – Low Dead Volume For fractional tube

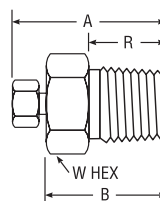
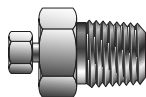

| CPI™ PART NO. | A-LOK® PART NO. | INCHES | | | | | | | INTERNAL OPENING | INTERNAL VOLUME |
|------------------|--------------------|----------------------|----------------|------|-----|-----|----------|------|---------------------|--------------------|
| | | NPT TUBE O. D. | PIPE THREAD | †A | B | R | W HEX | | | |
| 1-1 FBZ7 | 1-1 FLZ7 | 1/16 | 1/16 | .75 | .55 | .38 | 5/16 | .013 | 3.1 x 10-4cc | |
| 1-2 FBZ7 | 1-2 FLZ7 | 1/16 | 1/8 | .79 | .59 | .38 | 7/16 | .013 | 4.4 x 10-4cc | |
| 1-4 FBZ7 | 1-4 FLZ7 | 1/16 | 1/4 | 1.01 | .81 | .56 | 5/8 | .013 | 8.8 x 10-4cc | |

†Average Value

Dimensions for reference only, subject to change.

Sanitary Flange Fitting For fractional tube

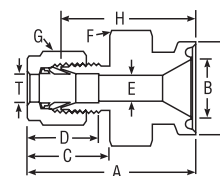
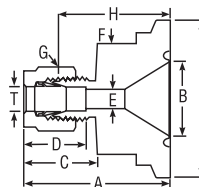

| CPI™ PART NO. | A-LOK® PART NO. | INTER- CHANGES WITH | INCHES | | | | | | | | | | |
|------------------|--------------------|---------------------------|---------------|--------------------|------|------|-----|-----|----------------------|------|------------------|------|------|
| | | | TUBE O. D. | SANITARY FLANGE | A | B | C | D | E MIN. OPENING | F | G HEX FLAT | H | I |
| 4-8 ZHBS | 4-8 ZHLS-SS | SS-400-SC-8 | 1/4 | 1/2 | 1.57 | .37 | .70 | .60 | .19 | 1.00 | 9/16 | 1.34 | .98 |
| 4-12 ZHBS | 4-12 ZHLS-SS | SS-400-SC-12 | 1/4 | 3/4 | 1.57 | .62 | .70 | .60 | .19 | 1.00 | 9/16 | 1.34 | .98 |
| 4-16 ZHBS | 4-16 ZHLS-SS | SS-400-SC-16 | 1/4 | 1 | 1.57 | .87 | .70 | .60 | .19 | 1.38 | 9/16 | 1.34 | 1.98 |
| 4-24 ZHBS | 4-24 ZHLS-SS | SS-400-SC-24 | 1/4 | 1 1/2 | 1.57 | 1.37 | .70 | .60 | .19 | 1.38 | 9/16 | 1.28 | 1.98 |
| 6-8 ZHBS | 6-8 ZHLS-SS | SS-600-SC-8 | 3/8 | 1/2 | 1.63 | .37 | .76 | .66 | .28 | 1.00 | 11/16 | 1.34 | .98 |
| 6-12 ZHBS | 6-12 ZHLS-SS | SS-600-SC-12 | 3/8 | 3/4 | 1.63 | .62 | .76 | .66 | .28 | 1.00 | 11/16 | 1.34 | .98 |
| 6-16 ZHBS | 6-16 ZHLS-SS | SS-600-SC-16 | 3/8 | 1 | 1.63 | .87 | .76 | .66 | .28 | 1.38 | 11/16 | 1.34 | 1.98 |
| 6-24 ZHBS | 6-24 ZHLS-SS | SS-600-SC-24 | 3/8 | 1 1/2 | 1.63 | 1.37 | .76 | .66 | .28 | 1.38 | 11/16 | 1.34 | 1.98 |
| 8-8 ZHBS | 8-8 ZHLS-SS | SS-810-SC-8 | 1/2 | 1/2 | 1.74 | .37 | .90 | .86 | .37 | 1.00 | 7/8 | 1.40 | .98 |
| 8-12 ZHBS | 8-12 ZHLS-SS | SS-810-SC-12 | 1/2 | 3/4 | 1.74 | .62 | .90 | .86 | .41 | 1.00 | 7/8 | 1.34 | .98 |
| 8-16 ZHBS | 8-16 ZHLS-SS | SS-810-SC-16 | 1/2 | 1 | 1.74 | .87 | .90 | .86 | .41 | 1.38 | 7/8 | 1.34 | 1.98 |
| 8-24 ZHBS | 8-24 ZHLS-SS | SS-810-SC-24 | 1/2 | 1 1/2 | 1.74 | 1.37 | .90 | .86 | .41 | 1.38 | 7/8 | 1.34 | 1.98 |

NOTE: A, C, and D dimensions are typical finger tight.

Dimensions for reference only, subject to change.

Sanitary flange fittings combine the reliability and versatility of Parker tube fittings with conventional sanitary flanges. The fittings permit direct downstream connections for hookups and sampling.

Flange sizes are 1/2, 3/4, 1, and 1-1/2 in.

Parker tube fitting ends are available in 1/4, 3/8, and 1/2 in. Parker tube fittings allow use of a variety of tubing materials including metal, hard plastic, and soft plastic.

For a Thermocouple/"Bored-Thru" version of the above Sanitary Adapter fittings, add a "4" to the part number. Example: A 4-12 ZHLS-SS becomes a 4-12 ZH4LS-SS for a 3/4" Sanitary Flange with a 1/4" diameter bored through on the A-LOK® fitting end.

For the full line of Sanitary Fittings and Flow Components, see Catalog 4270-Sanitary/ASME-BPE Fittings.

Barbed Connector to Male Pipe For fractional tube

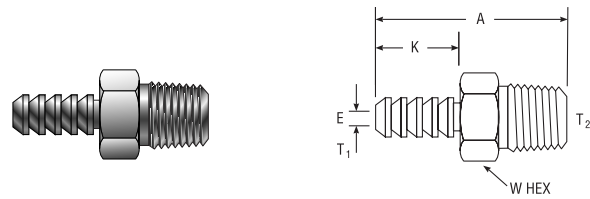

| CPI™ PART NO. | A-LOK® PART NO. | INTER- CHANGES WITH | INCHES | | | | | |
|------------------|--------------------|---------------------------|-------------------|-------------------------------------|------|-----------|------|----------|
| | | | T HOSE I.D. | T ₂ MALE PIPE SIZE | A | E BORE | K | W HEX |
| 2-2 B2HF | 2-2 B2HF | 2-HC-1-2 | 1/8 | 1/8 | 1.00 | .078 | 0.41 | 7/16 |
| 2-4 B2HF | 2-4 B2HF | 2-HC-1-4 | 1/8 | 1/4 | 1.22 | .078 | 0.41 | 9/16 |
| 4-2 B2HF | 4-2 B2HF | 4-HC-1-2 | 1/4 | 1/8 | 1.41 | .188 | 0.75 | 7/16 |
| 4-4 B2HF | 4-4 B2HF | 4-HC-1-4 | 1/4 | 1/4 | 1.59 | .188 | 0.78 | 9/16 |
| 5-2 B2HF | 5-2 B2HF | 5-HC-1-2 | 5/16 | 1/8 | 1.50 | .188 | 0.88 | 7/16 |
| 5-4 B2HF | 5-4 B2HF | 5-HC-1-4 | 5/16 | 1/4 | 1.69 | .250 | 0.88 | 9/16 |
| 6-4 B2HF | 6-4 B2HF | 6-HC-1-4 | 3/8 | 1/4 | 1.72 | .281 | 0.88 | 9/16 |
| 6-6 B2HF | 6-6 B2HF | 6-HC-1-6 | 3/8 | 3/8 | 1.72 | .297 | 0.88 | 11/16 |
| 8-6 B2HF | 8-6 B2HF | 8-HC-1-6 | 1/2 | 3/8 | 1.81 | .375 | 0.94 | 3/4 |
| 8-8 B2HF | 8-8 B2HF | 8-HC-1-8 | 1/2 | 1/2 | 2.00 | .375 | 0.94 | 7/8 |
| 12-12 B2HF | 12-12 B2HF | 12-HC-1-12 | 3/4 | 3/4 | 2.13 | .625 | 1.03 | 1-1/16 |

Dimensions for reference only, subject to change.

Barbed Connector to Tube Adapter For fractional tube

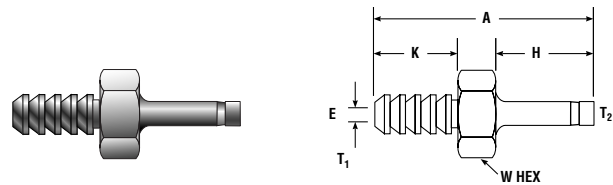

| CPI™ PART NO. | A-LOK® PART NO. | INTER- CHANGES WITH | INCHES | | | | | | |
|------------------|--------------------|---------------------------|--------------------------------|--------------------------------|------|-----------|-----|-----|----------|
| | | | T ₁ TUBE I.D. | T ₂ TUBE O.D. | A | E BORE | H | K | W HEX |
| 2-2 B2HT2 | 2B2TU2 | 2-HC-A-201 | 1/8 | 1/8 | 1.16 | .078 | .53 | .41 | 5/16 |
| 2-4 B2HT2 | 2B2TU4 | 2-HC-A-401 | 1/8 | 1/4 | 1.26 | .078 | .64 | .41 | 3/8 |
| 4-4 B2HT2 | 4B2TU4 | 4-HC-A-401 | 1/4 | 1/4 | 1.64 | .156 | .64 | .78 | 3/8 |
| 6-6 B2HT2 | 6B2TU6 | 6-HC-A-601 | 3/8 | 3/8 | 1.75 | .156 | .72 | .78 | 7/16 |

Dimensions for reference only, subject to change.

NOTE: Tube adapter end is designed for use with Parker fittings or valves. Simply insert the tube adapter end until it bottoms and tighten the Parker nut 3/4 turns for sizes 3 and below, for sizes 4 and above 1-1/4 turns from finger tight.

Add -Z6 for assembly of nuts and ferrules on the tube stub end.

Hose Connector Sleeve For fractional tube



| PARKER PART NO. | INCHES | | | |
|--------------------|--------------|--------------|------|----------|
| | HOSE I.D. | HOSE O.D. | L | W HEX |
| HCS 2-4 | 1/8 | 1/4 | 0.41 | 3/8 |
| HCS 4-6 | 1/4 | 3/8 | 0.78 | 9/16 |
| HCS 4-7 | 1/4 | 7/16 | 0.78 | 5/8 |
| HCS 4-8 | 1/4 | 1/2 | 0.78 | 11/16 |
| HCS 4-9 | 1/4 | 9/16 | 0.78 | 3/4 |
| HCS 5-7 | 5/16 | 7/16 | 0.88 | 5/8 |
| HCS 6-8 | 3/8 | 1/2 | 0.88 | 11/16 |
| HCS 6-9 | 3/8 | 9/16 | 0.88 | 3/4 |
| HCS 8-11 | 1/2 | 11/16 | 0.94 | 7/8 |
| HCS 12-16 | 3/4 | 1 | 1.06 | 1-1/4 |

Dimensions for reference only, subject to change.

Color Coding

For easy reference, table column headings are color indicated as follows:

fractional



metric



Insert

For fractional tube

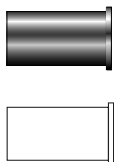

| PARKER PART NO. | INTER-CHANGES WITH | INCHES | | |
|-----------------|--------------------|-----------|-----------|-----------|
| | | TUBE O.D. | TUBE I.D. | TUBE WALL |
| 3 TIZ .125 | 305-2 | 3/16 | .125 | .031 |
| 4 TIZ .125 | 405-2 | 1/4 | .125 | .062 |
| 4 TIZ .170 | 405-170 | 1/4 | .170 | .040 |
| 4 TIZ .188 | 405-3 | 1/4 | .188 | .031 |
| 5 TIZ .125 | 505-2 | 5/16 | .125 | .094 |
| 5 TIZ .188 | 505-3 | 5/16 | .188 | .062 |
| 5 TIZ .250 | 505-4 | 5/16 | .250 | .031 |
| 6 TIZ .188 | 605-3 | 3/8 | .188 | .094 |
| 6 TIZ .250 | 605-4 | 3/8 | .250 | .062 |
| 8 TIZ .250 | 815-4 | 1/2 | .250 | .125 |
| 8 TIZ .375 | 815-6 | 1/2 | .375 | .062 |
| 10 TIZ .375 | 1015-6 | 5/8 | .375 | .125 |
| 10 TIZ .500 | 1015-8 | 5/8 | .500 | .062 |
| 12 TIZ .500 | 1215-8 | 3/4 | .500 | .125 |
| 12 TIZ .625 | 1215-10 | 3/4 | .625 | .062 |
| 16 TIZ .750 | 1615-12 | 1 | .750 | .125 |
| 16 TIZ .875 | 1615-14 | 1 | .875 | .062 |

Dimensions for reference only, subject to change.

NOTE: Tubing wall thickness and corresponding minimum I.D. flow paths are listed so the system designer can properly match the insert to the tubing.

Example: 4 TIZ .125 is used with tubing having a wall thickness of .062 and I.D. of .125.

Insert

For metric tube

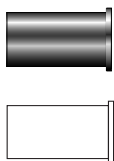

| PARKER PART NO. | INTER-CHANGES WITH | MILLIMETERS | | |
|-----------------|--------------------|-------------|-----------|-----------|
| | | TUBE O.D. | TUBE I.D. | TUBE WALL |
| TIZ 6 (4) | 6M5-4M | 6 | 4 | 1,0 |
| TIZ 8 (6) | 8M5-6M | 8 | 6 | 1,0 |
| TIZ 10 (6) | 10M5-6M | 10 | 6 | 2,0 |
| TIZ 10 (8) | 10M5-8M | 10 | 8 | 1,0 |
| TIZ 12 (8) | 12M5-8M | 12 | 8 | 2,0 |
| TIZ 12 (10) | 12M5-10M | 12 | 10 | 1,0 |
| TIZ 15 (10) | 15M5-10M | 15 | 10 | 2,5 |

Dimensions for reference only, subject to change.

NOTE: Tubing wall thickness and corresponding minimum I.D. flow paths are listed so the system designer can properly match the insert to the tubing.

Example: TIZ 6 (4) is used with tubing having a wall thickness of 1mm and I.D. of 4mm.

TIZ inserts allow CPI™/A-LOK® fittings to be used with soft plastic tubing.

Tube Nut

For fractional tube

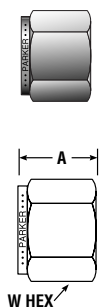

| CPI™ PART NO. | A-LOK® PART NO. | INTER-CHANGES WITH | INCHES | | |
|---------------|-----------------|--------------------|-----------|------|-------|
| | | | TUBE O.D. | A | W HEX |
| 1 BZ | 1NU1 | 102-1 | 1/16 | 0.31 | 5/16 |
| 2 BZ | 2NU2 | 202-1 | 1/8 | 0.47 | 7/16 |
| 3 BZ | 3NU3 | 302-1 | 3/16 | 0.47 | 1/2 |
| 4 BZ | 4NU4 | 402-1 | 1/4 | 0.50 | 9/16 |
| 5 BZ | 5NU5 | 502-1 | 5/16 | 0.53 | 5/8 |
| 6 BZ | 6NU6 | 602-1 | 3/8 | 0.56 | 11/16 |
| 8 BZ | 8NU8 | 812-1 | 1/2 | 0.69 | 7/8 |
| 10 BZ | 10NU10 | 1012-1 | 5/8 | 0.69 | 1 |
| 12 BZ | 12NU12 | 1212-1 | 3/4 | 0.69 | 1-1/8 |
| 14 BZ | 14NU14 | 1412-1 | 7/8 | 0.69 | 1-1/4 |
| 16 BZ | 16NU16 | 1612-1 | 1 | 0.81 | 1-1/2 |
| 20 BZ | 20NU20 | 2012-1 | 1-1/4 | 1.25 | 1-7/8 |
| 24 BZ | 24NU24 | 2412-1 | 1-1/2 | 1.50 | 2-1/4 |
| 32 BZ | 32NU32 | 3212-1 | 2 | 2.06 | 3 |

Dimensions for reference only, subject to change.

NOTE: All size 20, 24 and 32 silver plated nuts should have a system compatible lube (Permatex Anti-seize – Parker Catalog 4290-INST) or equivalent applied to the fitting body threads and the inside back of nuts. This will minimize the effort required to assemble the fitting properly.

Tube Nut For metric tube

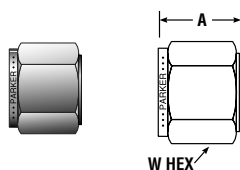

| CPI™ PART NO. | A-LOK® PART NO. | INTER- CHANGES WITH | UN THREAD | MILLIMETERS | | |
|------------------|--------------------|---------------------------|--------------|--------------|------|----------|
| | | | | TUBE O.D. | A | W HEX |
| BZ 2 | NUM2 | 2M2-1 | 5/16-20 | 2 | 11,9 | 12,0 |
| BZ 3 | NUM3 | 3M2-1 | 5/16-20 | 3 | 11,9 | 12,0 |
| BZ 4 | NUM4 | 4M2-1 | 3/8-20 | 4 | 11,9 | 12,0 |
| BZ 6 | NUM6 | 6M2-1 | 7/16-20 | 6 | 12,7 | 14,0 |
| BZ 8 | NUM8 | 8M2-1 | 1/2-20 | 8 | 13,5 | 16,0 |
| BZ 10 | NUM10 | 10M2-1 | 5/8-20 | 10 | 15,1 | 19,0 |
| BZ 12 | NUM12 | 12M2-1 | 3/4-20 | 12 | 17,5 | 22,0 |
| BZ 14 | NUM14 | 14M2-1 | 7/8-20 | 14 | 17,5 | 25,0 |
| BZ 15 | NUM15 | 15M2-1 | 7/8-20 | 15 | 17,5 | 25,0 |
| BZ 16 | NUM16 | 16M2-1 | 7/8-20 | 16 | 17,5 | 25,0 |
| BZ 18 | NUM18 | 18M2-1 | 1-20 | 18 | 17,5 | 30,0 |
| BZ 20 | NUM20 | 20M2-1 | 1.1/8-20 | 20 | 17,5 | 32,0 |
| BZ 22 | NUM22 | 22M2-1 | 1.1/8-20 | 22 | 17,5 | 32,0 |
| BZ 25 | NUM25 | 25M2-1 | 1.5/16-20 | 25 | 20,6 | 38,0 |

Dimensions for reference only, subject to change.

Inverted Tube Nut For fractional tube

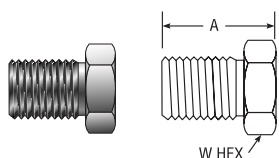

| PARKER PART NO. | INTER- CHANGES WITH | INCHES | | |
|--------------------|---------------------------|--------------|-----|----------|
| | | TUBE O.D. | A | W HEX |
| 1 BZI | 1F2-1GC | 1/16 | .39 | 1/4 |
| 2 BZI | 2F2-1GC | 1/8 | .44 | 7/16 |

Dimensions for reference only, subject to change.

Knurled Nut For fractional tube

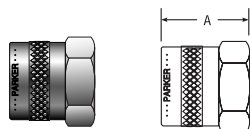

| PARKER PART NO. | INTER- CHANGES WITH | INCHES | |
|--------------------|---------------------------|--------------|-----|
| | | TUBE O.D. | A |
| 1 BZP | 102-1K | 1/16 | .32 |
| 2 BZP | 202-1K | 1/8 | .47 |
| 3 BZP | 302-1K | 3/16 | .47 |
| 4 BZP | 402-1K | 1/4 | .51 |
| 5 BZP | 502-1K | 5/16 | .54 |
| 6 BZP | 812-1K | 3/8 | .57 |
| 8 BZP | 602-1K | 1/2 | .69 |
| 10 BZP | 1012-1K | 5/8 | .69 |

Dimensions for reference only, subject to change.

HOW TO ASSEMBLE BZP

1. Replaces BZ/NU nuts on Parker CPI™/A-LOK® fitting bodies.
2. Insert plastic tubing until it bottoms in fitting body.
3. Tighten finger tight.

The knurled nut is designed for use with soft plastic tubing on low pressure applications where a finger tight assembly procedure is satisfactory.

Example: Laboratory test hook-ups. Nylon or PTFE ferrules are frequently used instead of metal ferrules in this type of application.

Ferrules



| PARKER PART NO. | INCHES TUBE O.D. |
|--------------------|---------------------|
| 1 TZ | 1/16 |
| 2 TZ | 1/8 |
| 3 TZ | 3/16 |
| 4 TZ | 1/4 |
| 5 TZ | 5/16 |
| 6 TZ | 3/8 |
| 8 TZ | 1/2 |
| 10 TZ | 5/8 |
| 12 TZ | 3/4 |
| 14 TZ | 7/8 |
| 16 TZ | 1 |
| 20 TZ | 1-1/4 |
| 24 TZ | 1-1/2 |
| 32 TZ | 2 |

Dimensions for reference only, subject to change.

| PARKER PART NO. | MILLIMETER TUBE O.D. |
|--------------------|-------------------------|
| TZ 3 | 3 |
| TZ 6 | 6 |
| TZ 8 | 8 |
| TZ 10 | 10 |
| TZ 12 | 12 |
| TZ 16 | 16 |
| TZ 20 | 20 |
| TZ 25 | 25 |

Dimensions for reference only, subject to change.

Note: Ferrules are available in standard metal materials as well as standard plastics like PTFE and nylon. Please consult the factory for availability.

INCH Front Ferrule

For fractional tube

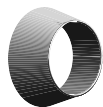

| PARKER PART NO. | INTER-CHANGES WITH | INCHES TUBE O. D. |
|-----------------|--------------------|-------------------|
| 1FF1 | 103-1 | 1/16 |
| 2FF2 | 203-1 | 1/8 |
| 3FF3 | 303-1 | 3/16 |
| 4FF4 | 403-1 | 1/4 |
| 5FF5 | 503-1 | 5/16 |
| 6FF6 | 603-1 | 3/8 |
| 8FF8 | 813-1 | 1/2 |
| 10FF10 | 1013-1 | 5/8 |
| 12FF12 | 1213-1 | 3/4 |
| 14FF14 | 1413-1 | 7/8 |
| 16FF16 | 1613-1 | 1 |
| 20FF20 | 2013-1 | 1-1/4 |
| 24FF24 | 2413-1 | 1-1/2 |
| 32FF32 | 3213-1 | 2 |

Note: Ferrules are available in standard metal materials as well as standard plastics like PTFE and nylon. Please consult the factory for availability.

METRIC Front Ferrule

For metric tube

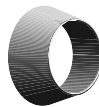

| PARKER PART NO. | INTER-CHANGES WITH | MM TUBE O. D. |
|-----------------|--------------------|---------------|
| FFM2 | 2M3-1 | 2 |
| FFM3 | 3M3-1 | 3 |
| FFM4 | 4M3-1 | 4 |
| FFM6 | 6M3-1 | 6 |
| FFM8 | 8M3-1 | 8 |
| FFM10 | 10M3-1 | 10 |
| FFM12 | 12M3-1 | 12 |
| FFM14 | 14M3-1 | 14 |
| FFM15 | 15M3-1 | 15 |
| FFM16 | 16M3-1 | 16 |
| FFM18 | 18M3-1 | 18 |
| FFM20 | 20M3-1 | 20 |
| FFM22 | 22M3-1 | 22 |
| FFM25 | 25M3-1 | 25 |

Note: Ferrules are available in standard metal materials as well as standard plastics like PTFE and nylon. Please consult the factory for availability.

INCH Back Ferrule

For fractional tube



For stainless steel, sizes 4-32 are Supercase ferrules.

| PARKER PART NO. | INTER-CHANGES WITH | INCHES TUBE O. D. |
|-----------------|--------------------|-------------------|
| 1BF1 | 104-1 | 1/16 |
| 2BF2 | 204-1 | 1/8 |
| 3BF3 | 304-1 | 3/16 |
| 4BF4 | 404-1 | 1/4 |
| 5BF5 | 504-1 | 5/16 |
| 6BF6 | 604-1 | 3/8 |
| 8BF8 | 814-1 | 1/2 |
| 10BF10 | 1014-1 | 5/8 |
| 12BF12 | 1214-1 | 3/4 |
| 14BF14 | 1414-1 | 7/8 |
| 16BF16 | 1614-1 | 1 |
| 20BF20 | 2014-1 | 1-1/4 |
| 24BF24 | 2414-1 | 1-1/2 |
| 32BF32 | 3214-1 | 2 |

Note: Ferrules are available in standard metal materials as well as standard plastics like PTFE and nylon. Please consult the factory for availability.

METRIC Back Ferrule

For metric tube



For stainless steel, sizes 6mm–25mm are Supercase ferrules.

| PARKER PART NO. | INTER-CHANGES WITH | MM TUBE O. D. |
|-----------------|--------------------|---------------|
| BFM2 | 2M4-1 | 2 |
| BFM3 | 3M4-1 | 3 |
| BFM4 | 4M4-1 | 4 |
| BFM6 | 6M4-1 | 6 |
| BFM8 | 8M4-1 | 8 |
| BFM10 | 10M4-1 | 10 |
| BFM12 | 12M4-1 | 12 |
| BFM14 | 14M4-1 | 14 |
| BFM15 | 15M4-1 | 15 |
| BFM16 | 16M4-1 | 16 |
| BFM18 | 18M4-1 | 18 |
| BFM20 | 20M4-1 | 20 |
| BFM22 | 22M4-1 | 22 |
| BFM25 | 25M4-1 | 25 |

Note: Ferrules are available in standard metal materials as well as standard plastics like PTFE and nylon. Please consult the factory for availability.

Ferrule Holder

Package simplifies ordering, stocking, and assembling

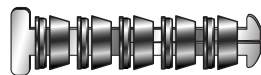

| CPI™ PART NO. | A-LOK® PART NO. | INCHES TUBE O. D. |
|---------------|-----------------|-------------------|
| 2 CPI*-SET | 2 ALOK*-SET | 1/8 |
| 4 CPI*-SET | 4 ALOK*-SET | 1/4 |
| 6 CPI*-SET | 6 ALOK*-SET | 3/8 |
| 8 CPI*-SET | 8 ALOK*-SET | 1/2 |
| 12 CPI*-SET | 12 ALOK*-SET | 3/4 |
| 16 CPI*-SET | 16 ALOK*-SET | 1 |

*Material designator – 316-SS, B-Brass, S-Steel

| CPI™ PART NO. | A-LOK® PART NO. | MM TUBE O. D. |
|---------------|-----------------|---------------|
| 6M CPI*-SET | 6M ALOK*-SET | 6 |
| 8M CPI*-SET | 8M ALOK*-SET | 8 |
| 10M CPI*-SET | 10M ALOK*-SET | 10 |
| 12M CPI*-SET | 12M ALOK*-SET | 12 |

*Material designator – 316-SS, B-Brass, S-Steel

The Parker ferrule holder offers a new convenience. The holder contains individual ferrule sets. Ferrule sets may be dispensed one at a time.

Color Coding

For easy reference, table column headings are color indicated as follows:

fractional



metric



Plug

For fractional tube

For plugging open ended CPI™/A-LOK® fitting ends

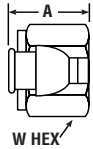

| CPI™ PART NO. | A-LOK® PART NO. | INTER- CHANGES WITH | INCHES | | | |
|------------------|--------------------|---------------------------|---------------|------------|------|----------|
| | | | TUBE O. D. | THREAD | A | W HEX |
| 1 FNZ | 1BLP1 | 100-P | 1/16 | 10-32 | 0.31 | 5/16 |
| 2 FNZ | 2BLP2 | 200-P | 1/8 | 5/16-20 | 0.47 | 7/16 |
| 3 FNZ | 3BLP3 | 300-P | 3/16 | 3/8-20 | 0.47 | 1/2 |
| 4 FNZ | 4BLP4 | 400-P | 1/4 | 7/16-20 | 0.50 | 9/16 |
| 5 FNZ | 5BLP5 | 500-P | 5/16 | 1/2-20 | 0.53 | 5/8 |
| 6 FNZ | 6BLP6 | 600-P | 3/8 | 9/16-20 | 0.56 | 11/16 |
| 8 FNZ | 8BLP8 | 810-P | 1/2 | 3/4-20 | 0.69 | 7/8 |
| 10 FNZ | 10BLP10 | 1010-P | 5/8 | 7/8-20 | 0.69 | 1 |
| 12 FNZ | 12BLP12 | 1210-P | 3/4 | 1-20 | 0.69 | 1-1/8 |
| 14 FNZ | 14BLP14 | 1410-P | 7/8 | 1-1/8-20 | 0.69 | 1-1/4 |
| 16 FNZ | 16BLP16 | 1610-P | 1 | 1-5/16-20 | 0.81 | 1-1/2 |
| 20 FNZ | 20BLP20 | 2010-P | 1-1/4 | 1-5/8-20 | 1.35 | 1-7/8 |
| 24 FNZ | 24BLP24 | 2410-P | 1-1/2 | 1-15/16-20 | 1.72 | 2-1/4 |
| 32 FNZ | 32BLP32 | 3210-P | 2 | 2-5/8-20 | 2.27 | 3 |

Dimensions for reference only, subject to change.

HOW TO ASSEMBLE

Wrench tighten only 1/4 turn from finger tight position. Assembly includes machined ferrule with lock ring.

Plug

For metric tube

For plugging open ended CPI™/A-LOK® fitting ends

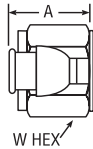

| CPI™ PART NO. | A-LOK® PART NO. | INTER- CHANGES WITH | MILLIMETERS | | | |
|------------------|--------------------|---------------------------|---------------|-----------|------|----------|
| | | | TUBE O. D. | THREAD | A | W HEX |
| FNZ 2 | BLPM2 | 2MO-P | 2 | 5/16-20 | 11,9 | 12,0 |
| FNZ 3 | BLPM3 | 3MO-P | 3 | 5/16-20 | 11,9 | 12,0 |
| FNZ 4 | BLPM4 | 4MO-P | 4 | 3/8-20 | 11,9 | 12,0 |
| FNZ 6 | BLPM6 | 6MO-P | 6 | 7/16-20 | 12,7 | 14,0 |
| FNZ 8 | BLPM8 | 8MO-P | 8 | 1/2-20 | 13,5 | 16,0 |
| FNZ 10 | BLPM10 | 10MO-P | 10 | 5/8-20 | 15,1 | 19,0 |
| FNZ 12 | BLPM12 | 12MO-P | 12 | 3/4-20 | 17,5 | 22,0 |
| FNZ 14 | BLPM14 | 14MO-P | 14 | 7/8-20 | 17,5 | 25,0 |
| FNZ 15 | BLPM15 | 15MO-P | 15 | 7/8-20 | 17,5 | 25,0 |
| FNZ 16 | BLPM16 | 16MO-P | 16 | 7/8-20 | 17,5 | 25,0 |
| FNZ 18 | BLPM18 | 18MO-P | 18 | 1-20 | 17,5 | 30,0 |
| FNZ 20 | BLPM20 | 20MO-P | 20 | 1-1/8-20 | 17,5 | 32,0 |
| FNZ 22 | BLPM22 | 22MO-P | 22 | 1-1/8-20 | 17,5 | 32,0 |
| FNZ 25 | BLPM25 | 25MO-P | 25 | 1-5/16-20 | 20,6 | 38,0 |

Dimensions for reference only, subject to change.

HOW TO ASSEMBLE

Wrench tighten only 1/4 turn from finger tight position. Assembly includes machined ferrule with lock ring.

Cap

For fractional tube

For capping open ended tubing

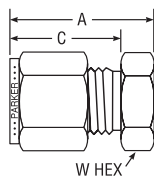
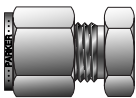

| CPI™ PART NO. | A-LOK® PART NO. | INTER- CHANGES WITH | INCHES | | | |
|------------------|--------------------|---------------------------|---------------|------|------|----------|
| | | | TUBE O. D. | A | C | W HEX |
| 1 PNBZ | 1BLEN1 | 100-C | 1/16 | 0.56 | 0.43 | 5/16 |
| 2 PNBZ | 2BLEN2 | 200-C | 1/8 | 0.79 | 0.60 | 7/16 |
| 3 PNBZ | 3BLEN3 | 300-C | 3/16 | 0.84 | 0.64 | 7/16 |
| 4 PNBZ | 4BLEN4 | 400-C | 1/4 | 0.92 | 0.70 | 1/2 |
| 5 PNBZ | 5BLEN5 | 500-C | 5/16 | 0.96 | 0.73 | 9/16 |
| 6 PNBZ | 6BLEN6 | 600-C | 3/8 | 1.01 | 0.76 | 5/8 |
| 8 PNBZ | 8BLEN8 | 810-C | 1/2 | 1.15 | 0.87 | 13/16 |
| 10 PNBZ | 10BLEN10 | 1010-C | 5/8 | 1.18 | 0.87 | 15/16 |
| 12 PNBZ | 12BLEN12 | 1210-C | 3/4 | 1.25 | 0.87 | 1-1/16 |
| 14 PNBZ | 14BLEN14 | 1410-C | 7/8 | 1.31 | 0.87 | 1-3/16 |
| 16 PNBZ | 16BLEN16 | 1610-C | 1 | 1.52 | 1.05 | 1-3/8 |
| 20 PNBZ | 20BLEN20 | 2010-C | 1-1/4 | 2.09 | 1.52 | 1-3/4 |
| 24 PNBZ | 24BLEN24 | 2410-C | 1-1/2 | 2.53 | 1.77 | 2-1/8 |
| 32 PNBZ | 32BLEN32 | 3210-C | 2 | 3.41 | 2.47 | 2-3/4 |

NOTE: For body only specify PNZ.

Dimensions for reference only, subject to change.

A and C dimensions are typical finger-tight.

Cap

For metric tube

For capping open ended tubing

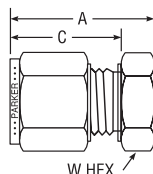
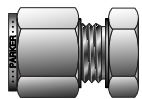

| CPI™ PART NO. | A-LOK® PART NO. | INTER- CHANGES WITH | MILLIMETERS | | | |
|------------------|--------------------|---------------------------|---------------|------|------|----------|
| | | | TUBE O. D. | A | C | W HEX |
| PNBZ 2 | BLENM2 | 2MO-C | 2 | 13,5 | 15,3 | 12,0 |
| PNBZ 3 | BLENM3 | 3MO-C | 3 | 13,5 | 15,3 | 12,0 |
| PNBZ 4 | BLENM4 | 4MO-C | 4 | 14,3 | 16,1 | 12,0 |
| PNBZ 6 | BLENM6 | 6MO-C | 6 | 15,9 | 17,7 | 14,0 |
| PNBZ 8 | BLENM8 | 8MO-C | 8 | 17,1 | 18,6 | 15,0 |
| PNBZ 10 | BLENM10 | 10MO-C | 10 | 19,1 | 19,5 | 18,0 |
| PNBZ 12 | BLENM12 | 12MO-C | 12 | 19,1 | 22,0 | 22,0 |
| PNBZ 14 | BLENM14 | 14MO-C | 14 | 19,8 | 22,0 | 24,0 |
| PNBZ 15 | BLENM15 | 15MO-C | 15 | 19,8 | 22,0 | 24,0 |
| PNBZ 16 | BLENM16 | 16MO-C | 16 | 19,8 | 22,0 | 24,0 |
| PNBZ 18 | BLENM18 | 18MO-C | 18 | 21,3 | 22,0 | 27,0 |
| PNBZ 20 | BLENM20 | 20MO-C | 20 | 23,9 | 22,0 | 30,0 |
| PNBZ 22 | BLENM22 | 22MO-C | 22 | 23,9 | 22,0 | 30,0 |
| PNBZ 25 | BLENM25 | 25MO-C | 25 | 26,2 | 26,5 | 35,0 |

NOTE: For body only specify PNZ.

Dimensions for reference only, subject to change.

A and C dimensions are typical finger-tight.

Vent Protector NPT Male Pipe Thread

For fractional tube

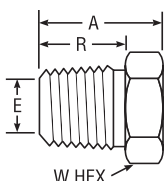

| CPI™ PART NO. | INTER- CHANGES WITH | THREAD SIZE | INCHES | | | |
|------------------|---------------------------|----------------|--------|-----|-------------------------|----------|
| | | | A | R | E MINIMUM OPENING | W HEX |
| 2 MDF | MS-MD-2M | 1/8-27 | 0.63 | .38 | .19 | 9/16 |
| 4 MDF | MS-MD-4M | 1/4-18 | 0.81 | .56 | .28 | 9/16 |
| 6 MDF | MS-MD-6M | 3/8-18 | 0.81 | .56 | .41 | 11/16 |
| 8 MDF | MS-MD-8M | 1/2-14 | 1.06 | .75 | .50 | 7/8 |
| 12 MDF | MS-MD-12M | 3/4-14 | 1.13 | .75 | .63 | 1-1/16 |
| 16 MDF | MS-MD-16M | 1-11-1/2 | 1.31 | .95 | .94 | 1-3/8 |

Dimensions for reference only, subject to change.

Parker Instrumentation vent protectors (mud dauber fittings) protect open ends of instruments, tubing, outlet vents, etc.

The mesh wire screen prevents foreign bodies such as insects or debris from entering and clogging various systems and causing damage.

- pipe plug, bored-thru design
- 40 x 40 mesh, .010 diameter wire screen
- designed to vent female pipe, straights, elbows or tees.

Color Coding

For easy reference, table column headings are color indicated as follows:

fractional



metric



Sealing Washers

Bonded Seals

Consists of an outer stainless steel ring with a fluorocarbon inner ring used to seal a male ISO parallel thread.

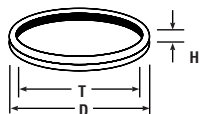

| PARKER PART NO. | T BSPP THREAD | D | H |
|-----------------|---------------|------|-----|
| M30201-SS | 1/8 | 0.63 | .08 |
| M30202-SS | 1/4 | 0.81 | .08 |
| M30203-SS | 3/8 | 0.94 | .08 |
| M30204-SS | 1/2 | 1.12 | .10 |
| M30206-SS | 3/4 | 1.38 | .10 |
| M30208-SS | 1 | 1.69 | .10 |

| PRESSURE RATINGS FOR SEALING WASHER | | |
|-------------------------------------|------|-----|
| THREAD SIZE | PSI | BAR |
| 1/8 | 5300 | 370 |
| 1/4 | 5500 | 380 |
| 3/8 | 4400 | 300 |
| 1/2 | 4000 | 280 |
| 3/4 | 3700 | 260 |
| 1 | 2800 | 190 |

Simply replace Suffix SS with S

Dimensions for reference only, subject to change.

These seals are also available in steel with a nitrile inner ring.

Copper Washers

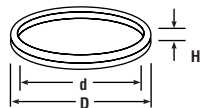

For BSPP male thread sealing

| PARKER PART NO. | THREAD | D | d | H |
|-----------------|--------|------|------|-----|
| M28329-CU | 1/8 | 0.71 | 0.39 | .09 |
| M28330-CU | 1/4 | 0.87 | 0.55 | .09 |
| M28331-CU | 3/8 | 0.94 | 0.67 | .09 |
| M28332-CU | 1/2 | 1.18 | 0.87 | .10 |
| M28334-CU | 3/4 | 1.38 | 1.06 | .09 |
| M28336-CU | 1 | 1.65 | 1.34 | .09 |

For BSPP female thread sealing

| PARKER PART NO. | THREAD | D | d | H |
|-----------------|--------|-------|------|------|
| M25179-CU | 1/8 | 0.322 | .188 | .062 |
| M25180-CU | 1/4 | 0.436 | .250 | .062 |
| M25181-CU | 3/8 | 0.574 | .375 | .062 |
| M25182-CU | 1/2 | 0.719 | .500 | .062 |
| M25184-CU | 3/4 | 0.935 | .719 | .062 |
| M25186-CU | 1 | 1.178 | .969 | .093 |

Dimensions for reference only, subject to change.

Used to provide a seal with male or female parallel ISO threads.

Please note the pressure ratings are based on taper threaded ends. The pressure rating for the BSPP ends are dependent on the type of sealing washer used.

Color Coding

For easy reference, table column headings are color indicated as follows:

fractional



metric



Bulkhead Locknut For fractional tube

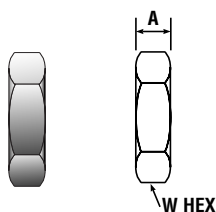

| PARKER PART NO. | INTER-CHANGES WITH | INCHES | | | |
|-----------------|--------------------|---------------|-----------|-----|--------|
| | | A-LOK® THREAD | TUBE O.D. | A | W HEX |
| 1 WLZ | 102-61 | 10-32 | 1/16 | .13 | 5/16 |
| 2 WLZ | 202-61 | 5/16-20 | 1/8 | .19 | 1/2 |
| 3 WLZ | 302-61 | 3/8-20 | 3/16 | .22 | 9/16 |
| 4 WLZ | 402-61 | 7/16-20 | 1/4 | .22 | 5/8 |
| 5 WLZ | 502-61 | 1/2-20 | 5/16 | .23 | 11/16 |
| 6 WLZ | 602-61 | 9/16-20 | 3/8 | .25 | 3/4 |
| 8 WLZ | 812-61 | 3/4-20 | 1/2 | .28 | 15/16 |
| 10 WLZ | 1012-61 | 7/8-20 | 5/8 | .31 | 1-1/16 |
| 12 WLZ | 1212-61 | 1"-20 | 3/4 | .34 | 1-3/16 |
| 14 WLZ | 1412-61 | 1-1/8-20 | 7/8 | .38 | 1-3/8 |
| 16 WLZ | 1612-61 | 1-5/16-20 | 1 | .38 | 1-5/8 |

Dimensions for reference only, subject to change.

Bulkhead Locknut For fractional tube

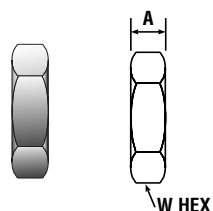

| PARKER PART NO. | INCHES | | | |
|-----------------|----------------------|-----------|-----|-------|
| | SAE ADJ. STR. THREAD | TUBE O.D. | A | W HEX |
| 4 WLN | 7/16-20 | 1/4 | .28 | 11/16 |
| 6 WLN | 9/16-18 | 3/8 | .27 | 13/16 |
| 8 WLN | 3/4-16 | 1/2 | .31 | 1 |
| 12 WLN | 1-1/16-12 | 3/4 | .41 | 1-3/8 |
| 16 WLN | 1-5/16-12 | 1 | .41 | 1-5/8 |

Dimensions for reference only, subject to change.

Bulkhead Locknut For metric tube

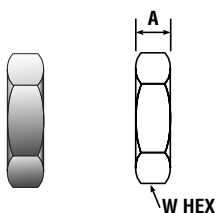

| PARKER PART NO. | MILLIMETERS | | | |
|-----------------|----------------------|-------------|-----|-------|
| | SAE ADJ. STR. THREAD | TUBE O.D. | A | W HEX |
| 2BN2 | 5/16-20 | 2 & 3 | 4,8 | 13,0 |
| 3BN3 | 3/8-20 | 4 | 5,6 | 14,0 |
| 4BN4 | 7/16-20 | 6 | 5,6 | 16,0 |
| 5BN5 | 1/2-20 | 8 | 5,6 | 17,0 |
| BNM10 | 5/8-20 | 10 | 6,4 | 21,0 |
| 8BN8 | 3/4-20 | 12 | 7,1 | 24,0 |
| 10BN10 | 7/8-20 | 14, 15 & 16 | 7,9 | 27,0 |
| 12BN12 | 1-20 | 18 | 8,6 | 30,0 |
| 14BN14 | 1-1/8-20 | 20 & 22 | 9,7 | 33,0 |
| 16BN16 | 1-5/16-20 | 25 | 9,7 | 41,0 |

Dimensions for reference only, subject to change.

Accessory Locknut

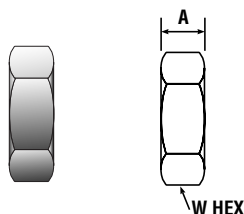

| PARKER PART NO. | INCHES | | |
|-----------------|-----------------|-----|-------|
| | STRAIGHT THREAD | A | W HEX |
| 2 L5NR | 5/16-24 | .22 | 7/16 |
| 3 L5NR | 3/8-24 | .22 | 1/2 |
| 4 L5NR | 7/16-20 | .28 | 9/16 |
| 5 L5NR | 1/2-20 | .28 | 5/8 |
| 6 L5NR | 9/16-18 | .28 | 11/16 |
| 8 L5NR | 3/4-16 | .31 | 7/8 |
| 10 L5NR | 7/8-14 | .36 | 1 |
| 12 L5NR | 1-1/16-12 | .41 | 1-1/4 |
| 14 L5NR | 1-3/16-12 | .41 | 1-3/8 |
| 16 L5NR | 1-5/16-12 | .41 | 1-1/2 |

Dimensions for reference only, subject to change.

NOTE: For use with M2SC and M2TU fittings on pages 55 and 56.

Assembly & Remake Instructions

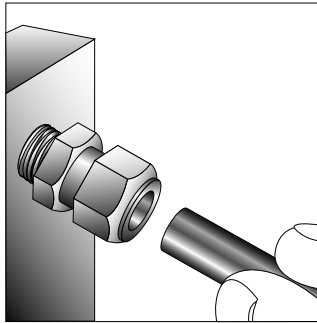

INCH SIZE 1 thru 3
(1/16" - 3/16")
METRIC SIZE 2 thru 4
(2-4mm)

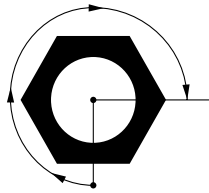

Only 3/4 turn from finger tight is necessary to seal and will result in additional remakes of the fitting

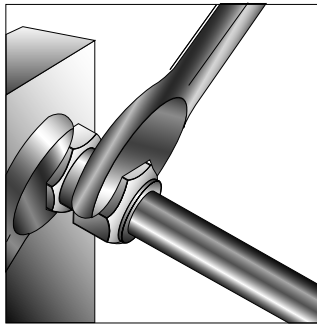

INCH SIZE 4 thru 16
(1/4" - 1")
METRIC SIZE 6 thru 25
(6-25mm)

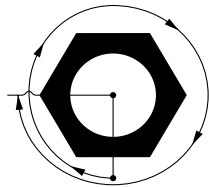

1-1/4 Turns from Finger Tight

1. Parker instrument tube fittings are sold completely assembled and ready for immediate use. Simply insert the tube as illustrated until it bottoms in the fitting body. (If the fitting is disassembled, note that the small tapered end of the ferrule(s) go into the fitting body.)
2. Tighten nut finger tight. Then tighten nut with wrench an additional 3/4 or 1-1/4 turns indicated at left. Hold fitting body with a second wrench to prevent body from turning. It is helpful to mark the nut to facilitate counting the number of turns.

For maximum number of remakes, mark the fitting and nut before disassembly. Before retightening, make sure the assembly has been inserted into the fitting until the ferrule seats in the fitting. Retighten the nut by hand. Rotate the nut with a wrench to the original position as indicated by the previous marks lining up. (A noticeable increase in mechanical resistance will be felt indicating the ferrule is being re-sprung into sealing position.)

Only after several remakes will it become necessary to advance the nut slightly past the original position. This advance (indicated by B) need only be 10° - 20° (less than 1/3 of a hex flat).

For Sizes above 16 (1"), the Parker IPD Hydraulic Presetting Tool or Rotary Wrench Tool should be used. Cat. 4290-INST.

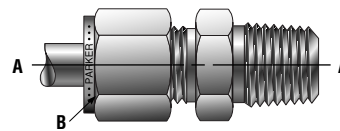

Parker CPI™/A-LOK® Tube Fitting part numbers use symbols to identify the size, style, and material. Tube and pipe thread sizes begin with a number indicating their size in sixteenths of an inch. For example, 4=4/16" or 1/4"; 16=16/16" or 1.

NOTE: Lubrication of the nut is REQUIRED for proper assembly on all LARGER size fittings in both inch and metric sizes. This requirement applies to:

- inch sizes of 20 and higher
- metric sizes of 25 and higher

Gaugeability Instructions*

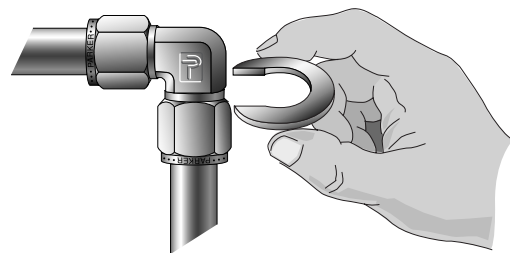
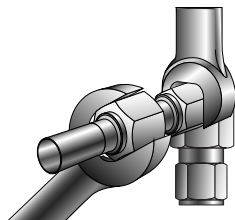

1. From "finger tight" position, wrench 1-1/4 turns for 1/4" to 1" size fittings (6mm to 25mm) (1/16", 1/8", 3/16", 2mm 3mm and 4mm size tube fittings only wrench 3/4 turn from finger tight position). Hold fitting body hex with second wrench to prevent body from turning as you tighten. It is a good idea to mark the nut (scribe or ink) to help you count the turns.
2. Now select the proper size inspection gauge and try to place it, as shown, between the nut and the body hex. If gauge DOES NOT FIT AT ANY POINT between them, you have correctly tightened the nut. If you can slip the gauge into the space, the fitting is not properly made up, and you must repeat the assembly procedure.

*For initial make up only.



Instrument Tubing Selection Guide

Parker's instrument tube fittings have been designed to work in a wide variety of applications that demand the utmost in product performance.

Although Parker's Instrument tube fittings have been engineered and manufactured to consistently provide this level of reliability, no systems integrity is complete without considering the critical link, tubing.

This booklet is intended to assist the designer to properly select and order quality tubing.

Proper tube selection and installation, we believe, are key ingredients in building leak-free reliable tubing systems.

General Selection Criteria

The most important consideration in the selection of suitable tubing for any application is the compatibility of the tubing material with the media to be contained. Table 1 lists common materials and their associated general application. Table 1 also lists the maximum and minimum operating temperature for the various tubing materials.

In addition, Parker instrument fittings are designed to work on like materials. Stainless steel fittings should be used only with stainless steel tubing, aluminum fittings with aluminum tubing, etc. The practice of mixing materials is strongly discouraged. The only exception is brass fittings with copper tubing.

Dissimilar materials in contact may be susceptible to galvanic corrosion. Further, different materials have different levels of hardness, and can adversely affect the fittings ability to seal on the tubing.

Table 1

| TUBING MATERIAL | GENERAL APPLICATION | RECOMMENDED TEMPERATURE RANGE |
|-----------------------------------|--|-------------------------------------|
| Stainless Steel (Type 316) | High Pressure, High Temperature, Generally Corrosive Media | -425°F to 1,200°F (-255°C to 605°C) |
| Carbon Steel | High Pressure, High Temperature Oil, Air, Some Specialty Chemicals | -20°F to 800°F (-29°C to 425°C) |
| Copper | Low Temperature, Low Pressure Water, Oil, Air | -40°F to 400°F (-40°C to 205°C) |
| Aluminum | Low Temperature, Low Pressure Water, Oil, Air, Some Specialty Chemicals | -40°F to 400°F (-40°C to 205°C) |
| Monel® 400 | Recommended for Sour Gas Applications Well Suited for Marine and General Chemical Processing Applications | -325°F to 800°F (-198°C to 425°C) |
| Hastelloy® C-276 | Excellent Corrosion Resistance to Both Oxidizing and Reducing Media and Excellent Resistance to Localized Corrosion Attack | -325°F to 1000°F (-198°C to 535°C) |
| Carpenter® 20 | Applications Requiring Resistance to Stress Corrosion Cracking in Extreme Conditions | -325°F to 800°F (-198°C to 425°C) |
| Inconel® Alloy 600 | Recommended for High Temperature Applications with Generally Corrosive Media | -205°F to 1200°F (-130°C to 650°C) |
| Titanium | Resistant to Many Natural Environments such as Sea Water, Body Fluids and Salt Solutions | -75°F to 600°F (-59°C to 315°C) |

- For operating temperatures above 800°F (425°C), consideration should be given to media. 300 Series Stainless Steels are susceptible to carbide precipitation which may lead to intergranular corrosion at elevated temperatures.
- Consideration should be given to maximum temperature ratings if fittings and/or tubing are coated or plated. All temperature ratings based on temperatures per ASME B31.3 Chemical Plant and Petroleum Refinery Piping Code, 1999 Edition.

The information listed in Table 1 is general in scope. For specific applications, please contact Parker's Instrumentation Products Division, Product Engineering Department (256) 881-2040.

NOTE: Hastelloy® is a registered trademark of Haynes International. Inconel®, and Monel® are registered trademarks of Special Metals Corporation. Carpenter® is a registered trademark of CRS Holdings Inc.

Gas Service

Special care must be taken when selecting tubing for gas service. In order to achieve a gas-tight seal, ferrules in instrument fittings must seal any surface imperfections. This is accomplished by the ferrules penetrating the surface of the tubing. Penetration can only be achieved if the tubing provides radial resistance and if the tubing material is softer than the ferrules.

Thick walled tubing helps to provide resistance. Tables 2–7 indicate the minimum acceptable wall thickness for various materials in gas service. The ratings in white indicate combination of diameter and wall thickness which are suitable for gas service.

Acceptable tubing hardness for general application is listed in Table 9. These values are the maximum allowed by ASTM. For gas service, better results can be obtained by using tubing well below this maximum hardness. For example, a desirable hardness of 80 Rb is suitable for stainless steel. The maximum allowed by ASTM is 90 Rb.

System Pressure

The system operating pressure is another important factor in determining the type, and more importantly, the size of tubing to be used. In general, high pressure installations require strong materials such as steel or stainless steel. Heavy walled softer tubing such as copper may be used if chemical compatibility exists with the media. However, the higher strength of steel or stainless steel permits the use of thinner tubes without reducing the ultimate rating of the system. In any event, tube fitting assemblies should never be pressurized beyond the recommended working pressure.

The following tables (2–7) list by material the maximum suggested working pressure of various tubing sizes. Acceptable tubing diameters and wall thicknesses are those for which a rating is listed. Combinations, which do not have a pressure rating, are not recommended for use with instrument fittings.

MAXIMUM ALLOWABLE WORKING PRESSURE TABLES

| Table 2 316 or 304 STAINLESS STEEL (Seamless) | | | | | | | | | | | | | | | | |
|---|----------------|-------|-------|-------|-------|-------|-------|-------|-------|-------|-------|-------|-------|-------|-------|-------|
| Tube O.D. Size | Wall Thickness | | | | | | | | | | | | | | | |
| | 0.010 | 0.012 | 0.014 | 0.016 | 0.020 | 0.028 | 0.035 | 0.049 | 0.065 | 0.083 | 0.095 | 0.109 | 0.120 | 0.134 | 0.156 | 0.188 |
| 1/16 | 5600 | 6900 | 8200 | 9500 | 12100 | 16800 | | | | | | | | | | |
| 1/8 | | | | | | 8600 | 10900 | | | | | | | | | |
| 3/16 | | | | | | 5500 | 7000 | 10300 | | | | | | | | |
| 1/4 | | | | | | 4000 | 5100 | 7500 | 10300 | | | | | | | |
| 5/16 | | | | | | | 4100 | 5900 | 8100 | | | | | | | |
| 3/8 | | | | | | | 3300 | 4800 | 6600 | | | | | | | |
| 1/2 | | | | | | | 2600 | 3700 | 5100 | 6700 | | | | | | |
| 5/8 | | | | | | | | 3000 | 4000 | 5200 | 6100 | | | | | |
| 3/4 | | | | | | | | 2400 | 3300 | 4300 | 5000 | 5800 | | | | |
| 7/8 | | | | | | | | 2100 | 2800 | 3600 | 4200 | 4900 | | | | |
| 1 | | | | | | | | | 2400 | 3200 | 3700 | 4200 | 4700 | | | |
| 1-1/4 | | | | | | | | | | 2500 | 2900 | 3300 | 3700 | 4100 | 4900 | |
| 1-1/2 | | | | | | | | | | | 2400 | 2700 | 3000 | 3400 | 4000 | 4500 |
| 2 | | | | | | | | | | | | 2000 | 2200 | 2500 | 2900 | 3200 |

| Table 3 316 or 304 STAINLESS STEEL (Welded) | | | | | | | | | | | | | | | | |
|---|----------------|-------|-------|-------|-------|-------|-------|-------|-------|-------|-------|-------|-------|-------|-------|-------|
| Tube O.D. Size | Wall Thickness | | | | | | | | | | | | | | | |
| | 0.010 | 0.012 | 0.014 | 0.016 | 0.020 | 0.028 | 0.035 | 0.049 | 0.065 | 0.083 | 0.095 | 0.109 | 0.120 | 0.134 | 0.156 | 0.188 |
| 1/16 | 4800 | 5900 | 7000 | 8100 | 10300 | 14300 | | | | | | | | | | |
| 1/8 | | | | | | 7300 | 9300 | | | | | | | | | |
| 3/16 | | | | | | 4700 | 6000 | 8700 | | | | | | | | |
| 1/4 | | | | | | 3400 | 4400 | 6400 | 8700 | | | | | | | |
| 5/16 | | | | | | | 3400 | 5000 | 6900 | | | | | | | |
| 3/8 | | | | | | | 2800 | 4100 | 5600 | | | | | | | |
| 1/2 | | | | | | | 2200 | 3200 | 4300 | 5700 | | | | | | |
| 5/8 | | | | | | | | 2500 | 3400 | 4500 | 5200 | | | | | |
| 3/4 | | | | | | | | 2100 | 2800 | 3700 | 4200 | 4900 | | | | |
| 7/8 | | | | | | | | 1800 | 2400 | 3100 | 3600 | 4200 | | | | |
| 1 | | | | | | | | | 2100 | 2700 | 3100 | 3600 | 4000 | | | |
| 1-1/4 | | | | | | | | | | 2100 | 2400 | 2800 | 3100 | 3500 | 4200 | |
| 1-1/2 | | | | | | | | | | | 2000 | 2300 | 2600 | 2900 | 3400 | 4200 |
| 2 | | | | | | | | | | | | 1700 | 1900 | 2100 | 2500 | 3000 |



| Tube O.D. Size | Wall Thickness | | | | | | | | | | | | |
|----------------|----------------|-------|-------|-------|-------|-------|-------|-------|-------|-------|-------|-------|--|
| | 0.028 | 0.035 | 0.049 | 0.065 | 0.083 | 0.095 | 0.109 | 0.120 | 0.134 | 0.148 | 0.165 | 0.180 | |
| 1/8 | 8100 | 10300 | | | | | | | | | | | |
| 3/16 | 5200 | 6700 | 9700 | | | | | | | | | | |
| 1/4 | 3800 | 4900 | 7100 | 9700 | | | | | | | | | |
| 5/16 | | 3800 | 5500 | 7700 | | | | | | | | | |
| 3/8 | | 3100 | 4500 | 6200 | | | | | | | | | |
| 1/2 | | 2300 | 3300 | 4500 | 6000 | | | | | | | | |
| 5/8 | | 1800 | 2600 | 3500 | 4600 | 5400 | | | | | | | |
| 3/4 | | | 2200 | 2900 | 3800 | 4400 | 5100 | | | | | | |
| 7/8 | | | 1800 | 2500 | 3200 | 3700 | 4300 | | | | | | |
| 1 | | | 1600 | 2100 | 2800 | 3200 | 3700 | 4100 | | | | | |
| 1-1/4 | | | | 1700 | 2200 | 2500 | 2900 | 3200 | 3700 | 3800 | | | |
| 1-1/2 | | | | | 1800 | 2100 | 2400 | 2700 | 3000 | 3400 | 3800 | 4000 | |
| 2 | | | | | | 1600 | 1800 | 2000 | 2200 | 2500 | 2800 | 3000 | |

| Tube O.D. Size | Wall Thickness | | | | |
|----------------|----------------|-------|-------|-------|-------|
| | 0.035 | 0.049 | 0.065 | 0.083 | 0.095 |
| 1/8 | 8700 | | | | |
| 3/16 | 5600 | 8100 | | | |
| 1/4 | 4100 | 5900 | | | |
| 5/16 | 3200 | 4600 | | | |
| 3/8 | 2600 | 3800 | | | |
| 1/2 | 1900 | 2800 | 3800 | | |
| 5/8 | 1500 | 2200 | 2900 | | |
| 3/4 | | 1800 | 2400 | 3200 | |
| 7/8 | | 1500 | 2100 | 2700 | |
| 1 | | 1300 | 1800 | 2300 | 2700 |

| Tube O.D. Size | Wall Thickness | | | | | | | | | |
|----------------|----------------|-------|-------|-------|-------|-------|-------|-------|-------|-------|
| | 0.010 | 0.020 | 0.028 | 0.035 | 0.049 | 0.065 | 0.083 | 0.095 | 0.109 | 0.120 |
| 1/16 | 1700 | 3800 | 5400 | | | | | | | |
| 1/8 | | | 2800 | 3600 | | | | | | |
| 3/16 | | | 1800 | 2300 | 3500 | | | | | |
| 1/4 | | | 1300 | 1700 | 2600 | 3500 | | | | |
| 5/16 | | | | 1300 | 2000 | 2800 | | | | |
| 3/8 | | | | 1100 | 1600 | 2300 | | | | |
| 1/2 | | | | 800 | 1200 | 1600 | 2200 | | | |
| 5/8 | | | | | 900 | 1300 | 1700 | 2000 | | |
| 3/4 | | | | | 800 | 1000 | 1400 | 1600 | 1900 | |
| 7/8 | | | | | 600 | 900 | 1100 | 1300 | 1600 | |
| 1 | | | | | 600 | 800 | 1000 | 1200 | 1400 | 1500 |
| 1-1/8 | | | | | 500 | 700 | 900 | 1000 | 1200 | 1300 |
| 1-1/4 | | | | | | | 800 | 900 | 1100 | 1200 |
| 1-1/2 | | | | | | | 650 | 750 | 850 | 950 |

| Tube O.D. Size | Wall Thickness | | | | | | | | | |
|----------------|----------------|-------|-------|-------|-------|-------|-------|-------|-------|-------|
| | 0.010 | 0.020 | 0.028 | 0.035 | 0.049 | 0.065 | 0.083 | 0.095 | 0.109 | 0.120 |
| 1/16 | 5500 | 11800 | 16300 | | | | | | | |
| 1/8 | | | 8100 | 10400 | | | | | | |
| 3/16 | | | 5100 | 6600 | 9600 | | | | | |
| 1/4 | | | 3800 | 4800 | 7000 | 9600 | | | | |
| 5/16 | | | | 3800 | 5500 | 7500 | | | | |
| 3/8 | | | | 3100 | 4500 | 6100 | | | | |
| 1/2 | | | | 2300 | 3300 | 4500 | 5900 | | | |
| 5/8 | | | | | 2700 | 3700 | 4900 | 5600 | | |
| 3/4 | | | | | 2300 | 3100 | 4000 | 4600 | 5400 | |
| 1 | | | | | | 2300 | 2900 | 3400 | 3900 | 4400 |

- NOTE:**
- All working pressures have been calculated using the maximum allowable stress levels in accordance with ASME B31.3, Chemical Plant and Petroleum Refinery Piping Code, 1999 Edition.
 - All calculations are based on maximum outside diameter and minimum wall thickness.
 - All working pressures are ambient (72°F or 22°C) temperature.

System Temperature

Operating temperature is another factor in determining the proper tubing material. Copper and aluminum tubing are suitable for low temperature media. Stainless steel and carbon steel tubing are suitable for higher temperature media. Special alloys such as Alloy 600 are recommended for extremely high temperatures (see Table 1). Table 8 lists derating factors which should be applied to the working pressures listed in Tables 2–7 for elevated temperature conditions. Simply locate the correct factor in Table 8 and multiply this by the appropriate value in Tables 2–7 for elevated temperature working pressure.

| Temperature | | Copper | Aluminum | 316 SS | 304 SS | Steel | Monel 400 |
|-------------|-------|--------|----------|--------|--------|-------|-----------|
| °F | (°C) | | | | | | |
| 100 | (38) | 1.00 | 1.00 | 1.00 | 1.00 | 1.00 | 1.00 |
| 200 | (93) | .80 | 1.00 | 1.00 | 1.00 | .96 | .88 |
| 300 | (149) | .78 | .81 | 1.00 | 1.00 | .90 | .82 |
| 400 | (204) | .50 | .40 | .97 | .94 | .86 | .79 |
| 500 | (260) | | | .90 | .88 | .82 | .79 |
| 600 | (316) | | | .85 | .82 | .77 | .79 |
| 700 | (371) | | | .82 | .80 | .73 | .79 |
| 800 | (427) | | | .80 | .76 | .59 | .76 |
| 900 | (486) | | | .78 | .73 | | .43 |
| 1000 | (538) | | | .77 | .69 | | |
| 1100 | (593) | | | .62 | .49 | | |
| 1200 | (649) | | | .37 | .30 | | |

EXAMPLE: 1/2 inch x .49 wall seamless 316 stainless steel tubing has a working pressure of 3700 psi @ room temperature. If the system were to operate @ 800°F (425°C), a factor of 80% or (.80) would apply (see Table 8 above) and the “at temperature” system pressure would be 3700 PSI x .80 = 2960 PSI.

Tubing Ordering Suggestions

Tubing for use with Parker instrument fittings must be carefully ordered to insure adequate quality for good performance. Each purchase order must specify the material nominal outside diameter, and wall thickness. Ordering to ASTM specifications insures that the tubing will be dimensionally, physically, and chemically within strict limits. Also, more stringent requirements may be added by the user. All tubing should be ordered free of scratches and suitable for bending.

A purchase order meeting the above criteria would read as follows:

“1/2 x .049 316 stainless steel, seamless, or welded and redrawn per ASTM A-249. Fully annealed, 80 Rb or less. Must be suitable for bending; surface scratches, and imperfections (incomplete weld seams) are not permissible.”

Table 9 lists specific ordering information for each material.

| Table 9 | | | | |
|--------------------|---------------------------|--------------------------------|------------------------|---------------------------|
| Material | Type | ASTM Tubing Spec. | Condition | Max. Recommended Hardness |
| Stainless Steel | 304, 316, 316L | ASTM-A-269, A-249, A-213, A632 | Fully Annealed | 90 Rb |
| Copper | K or L | ASTM-B75 B68, B88 (K or L)* | Soft Annealed Temper 0 | 60 Max. Rockwell 15T |
| Carbon Steel | 1010 | SAE-J524b, J525b ASTM-A-179 | Fully Annealed | 72 Rb |
| Aluminum | Alloy 6061 | ASTM B-210 | T6 Temper | 56 Rb |
| Monel® 400 | 400 | ASTM B-165 | Fully Annealed | 75 Rb |
| Hastelloy® C-276 | C-276 | ASTM-B-622, B-626 | Fully Annealed | 90 Rb |
| Inconel® Alloy 600 | 600 | ASTM B-167 | Fully Annealed | 90 Rb |
| Carpenter® 20 | 20CB-3 | ASTM B-468 | Fully Annealed | 90 Rb |
| Titanium | Commercially Pure Grade 2 | ASTM B-338 | Fully Annealed | 99 Rb 200 Brinell Typical |

*B88 Copper Tube to be ordered non-engraved

NOTE: Hastelloy® is a registered trademark of Haynes International. Inconel®, and Monel® are registered trademarks of Special Metals Corporation. Carpenter® is a registered trademark of CRS Holdings Inc.

Pipe Pressure Ratings

| NPT / BSPT Pipe Size | BRASS | | | |
|-------------------------|-----------------------|--------------------|-----------------------|--------------------|
| | Male | | Female | |
| | Straight ^a | Shape ^b | Straight ^a | Shape ^b |
| 1/16 | 6000 | 5500 | 4500 | 3800 |
| 1/8 | 5600 | 5000 | 4000 | 2900 |
| 1/4 | 4100 | 4100 | 4300 | 3000 |
| 3/8 | 4000 | 4000 | 3500 | 2700 |
| 1/2 | 3900 | 3100 | 3600 | 2500 |
| 3/4 | 3800 | 3400 | 3000 | 2000 |
| 1 | 2700 | 2700 | 3100 | 2300 |
| 1-1/4 | 2000 | 2000 | 2300 | 1900 |
| 1-1/2 | 1800 | 1800 | 2100 | 1700 |
| 2 | 1600 | 1600 | 2000 | 1500 |

| NPT / BSPT Pipe Size | STAINLESS STEEL | | | |
|-------------------------|-----------------------|--------------------|-----------------------|--------------------|
| | Male | | Female | |
| | Straight ^a | Shape ^b | Straight ^a | Shape ^b |
| 1/16 | 10000 | 9500 | 7500 | 7000 |
| 1/8 | 9100 | 9100 | 6400 | 5500 |
| 1/4 | 7500 | 7500 | 6600 | 5600 |
| 3/8 | 7200 | 7200 | 5300 | 5000 |
| 1/2 | 6600 | 5800 | 5200 | 4500 |
| 3/4 | 6400 | 6400 | 4300 | 3500 |
| 1 | 4600 | 4600 | 4500 | 3900 |
| 1-1/4 | 3500 | 3500 | 3500 | 3100 |
| 1-1/2 | 2900 | 2900 | 3200 | 2500 |
| 2 | 2600 | 2600 | 2700 | 2300 |

| NPT / BSPT Pipe Size | CARBON STEEL | | | |
|-------------------------|-----------------------|--------------------|-----------------------|--------------------|
| | Male | | Female | |
| | Straight ^a | Shape ^b | Straight ^a | Shape ^b |
| 1/16 | 10500 | 10100 | 8000 | 7500 |
| 1/8 | 9700 | 9700 | 6800 | 5900 |
| 1/4 | 8000 | 8000 | 7000 | 6000 |
| 3/8 | 7600 | 7600 | 5600 | 5300 |
| 1/2 | 7000 | 6200 | 5500 | 4800 |
| 3/4 | 6800 | 6800 | 4600 | 3700 |
| 1 | 4900 | 4900 | 4800 | 4200 |
| 1-1/4 | 3700 | 3700 | 3700 | 3300 |
| 1-1/2 | 3100 | 3100 | 3400 | 2600 |
| 2 | 2800 | 2800 | 2800 | 2400 |

Notes:

- a. Fittings manufactured from bar stock.
- b. Fittings manufactured from forgings.
- c. Material of construction in accordance with Parker Catalog 4230/4233, Table 1.
- d. Pressure ratings for fittings with both tube and pipe ends are rated to the lower pressure.













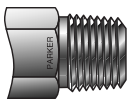
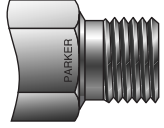

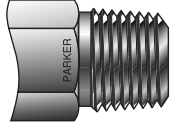
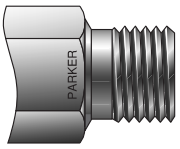

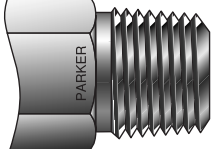
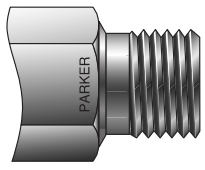

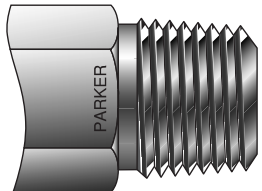
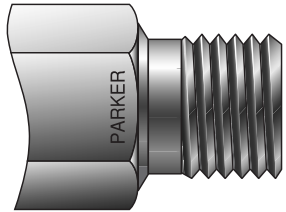
Thread & Tube End Size Chart (USA)

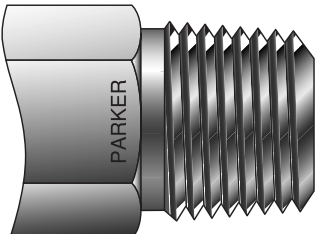
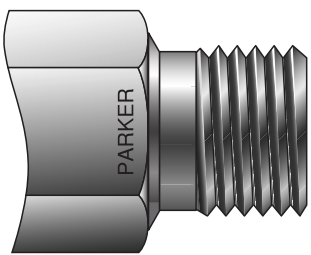
NPT Thread

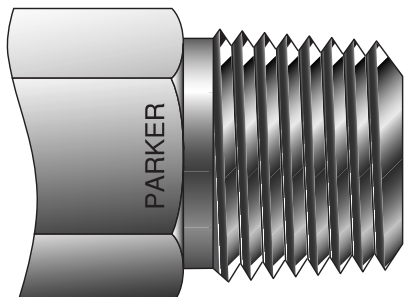
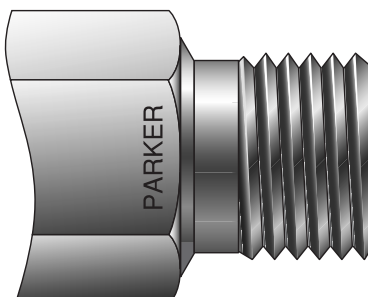
Straight Thread

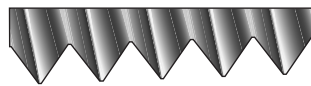
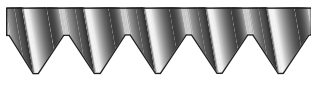
Tubing O.D. Size

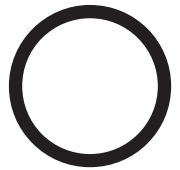
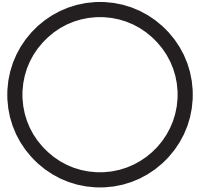
| | | | | | |
|---|--|--|--|---|-------|
|  | 1/16" |  | 5/16-24 |  | 1/16" |
|  | 1/8" (1/8-27) |  | 7/16-20 |  | 1/8" |
|  | 1/4" (1/4-18) |  | 1/2-20 |  | 3/16" |
|  | 3/8" (3/8-18) |  | 9/16-18 |  | 1/4" |
|  | 1/2" (1/2-14) |  | 3/4-16 |  | 5/16" |
|  | 3/4" (3/4-14) |  | 7/8-14 |  | 3/8" |
|  | 1" (1-11 1/2) |  | 1-1/16-12 |  | 1/2" |
|  | American Standard Pipe Thread (NPT) |  | American Standard Unified Thread (Straight) |  | 5/8" |
| | | | |  | 3/4" |
| | | | |  | 7/8" |
| | | | |  | 1" |

60° thread angle • Pitch measured in inches
 • Truncation of root and crest are flat
 • Taper angle 1°47'

60° thread angle • Pitch measured in inches
 • Truncation of root and crest are flat
 • Diameter measured in inches

Thread & Tube End Size Chart (USA)

NPT Thread

Tubing O.D. Size

Tubing O.D. Size

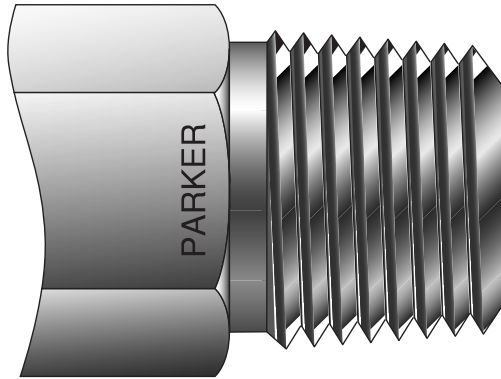

1-1/4"
(1-1/4" - 11-1/2")

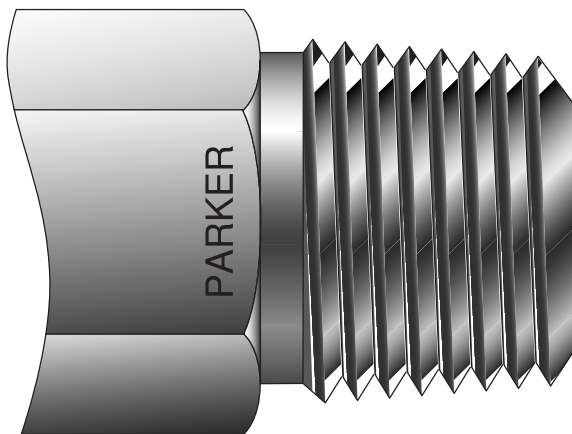
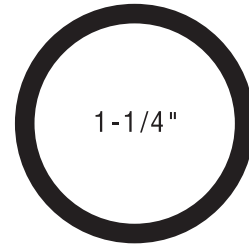

1-1/2"
(1-1/2" - 11-1/2")

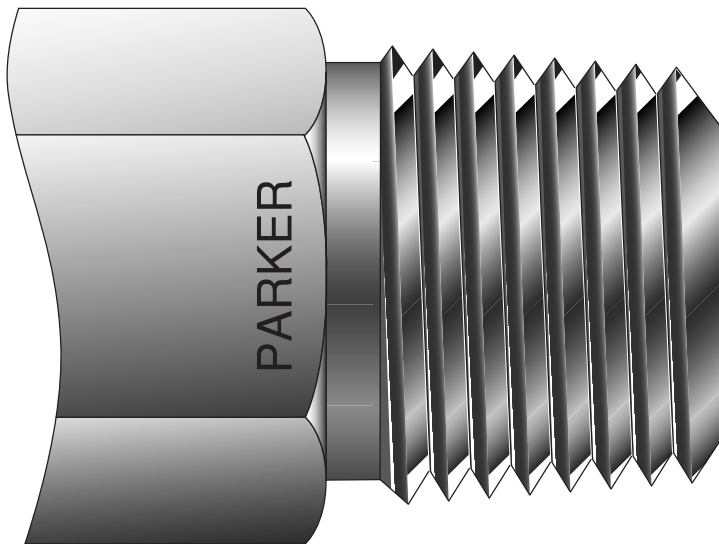
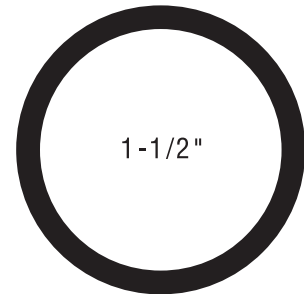

2"
(2" - 11-1/2")

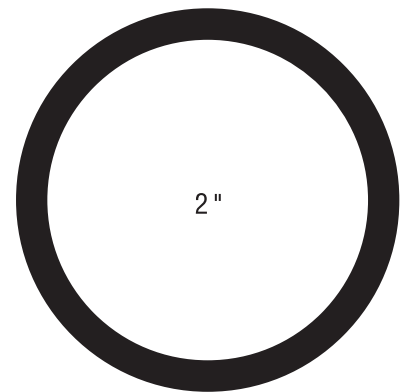









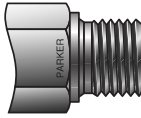

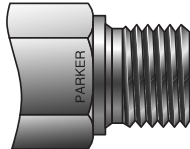

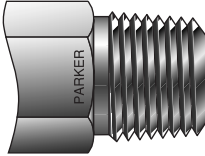
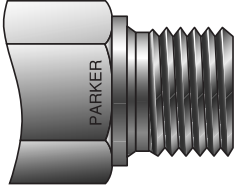

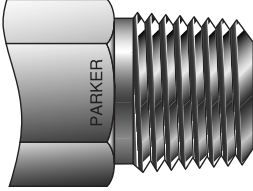
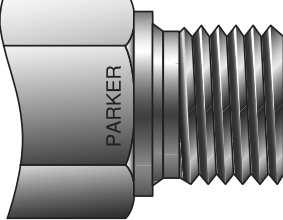

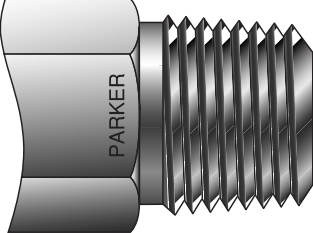
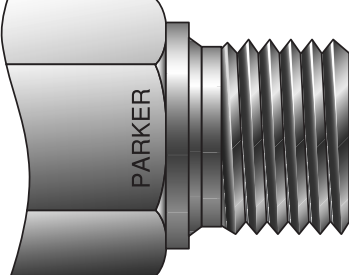

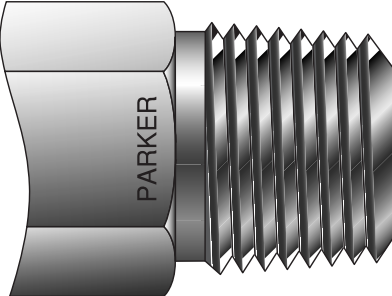
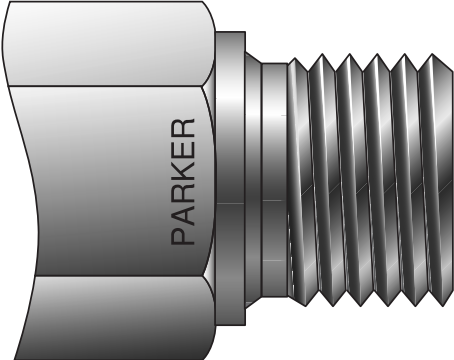

Thread & Tube End Size Chart (USA)

BSPT Tapered Thread

BSPP Parallel Thread

Tubing O.D. Size

| | | |
|--|--|--|
|  1/8" (1/8-28) |  1/8" (1/8-28) |  2 m m |
|  1/4" (1/4-19) |  1/4" (1/4-19) |  3 m m |
|  3/8" (3/8-19) |  3/8" (3/8-19) |  4 m m |
|  1/2" (1/2-14) |  1/2" (1/2-14) |  6 m m |
|  3/4" (3/4-14) |  3/4" (3/4-14) |  8 m m |
|  1" (1"-11) |  1" (1"-11) |  10 m m |
| | |  12 m m |
| | |  14 m m |
| | |  15 m m |
| | |  16 m m |
| | |  18 m m |
| | |  20 m m |
| | |  22 m m |
| | |  25 m m |

International Organization for Standards (ISO 7/1)

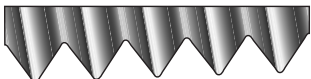

- 55° thread angle • Pitch measured in inches
- Truncation of root and crest are round
- Taper angle 1°47'

(ISO 228/1)

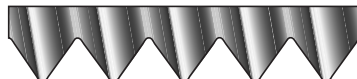

- 55° thread angle • Pitch measured in inches
- Truncation of root and crest are round
- Diameter measured in inches

Offer of Sale

The items described in this document and other documents and descriptions provided by Parker Hannifin Corporation, its subsidiaries and its authorized distributors ("Seller") are hereby offered for sale at prices to be established by Seller. This offer and its acceptance by any customer ("Buyer") shall be governed by all of the following Terms and Conditions. Buyer's order for any item described in its document, when communicated to Seller verbally, or in writing, shall constitute acceptance of this offer. All goods or work described will be referred to as "Products".

1. Terms and Conditions. Seller's willingness to offer Products, or accept an order for Products, to or from Buyer is expressly conditioned on Buyer's assent to these Terms and Conditions and to the terms and conditions found on-line at www.parker.com/saleterms/. Seller objects to any contrary or additional term or condition of Buyer's order or any other document issued by Buyer.

2. Price Adjustments; Payments. Prices stated on the reverse side or preceding pages of this document are valid for 30 days. After 30 days, Seller may change prices to reflect any increase in its costs resulting from state, federal or local legislation, price increases from its suppliers, or any change in the rate, charge, or classification of any carrier. The prices stated on the reverse or preceding pages of this document do not include any sales, use, or other taxes unless so stated specifically. Unless otherwise specified by Seller, all prices are F.O.B. Seller's facility, and payment is due 30 days from the date of invoice. After 30 days, Buyer shall pay interest on any unpaid invoices at the rate of 1.5% per month or the maximum allowable rate under applicable law.

3. Delivery Dates; Title and Risk; Shipment. All delivery dates are approximate and Seller shall not be responsible for any damages resulting from any delay. Regardless of the manner of shipment, title to any products and risk of loss or damage shall pass to Buyer upon tender to the carrier at Seller's facility (i.e., when it's on the truck, it's yours). Unless otherwise stated, Seller may exercise its judgment in choosing the carrier and means of delivery. No deferment of shipment at Buyers' request beyond the respective dates indicated will be made except on terms that will indemnify, defend and hold Seller harmless against all loss and additional expense. Buyer shall be responsible for any additional shipping charges incurred by Seller due to Buyer's changes in shipping, product specifications or in accordance with Section 13, herein.

4. Warranty. Seller warrants that the Products sold hereunder shall be free from defects in material or workmanship for a period of twelve months from the date of delivery to Buyer or 2,000 hours of normal use, whichever occurs first. This warranty is made only to Buyer and does not extend to anyone to whom Products are sold after purchased from Seller. The prices charged for Seller's products are based upon the exclusive limited warranty stated above, and upon the following disclaimer: **DISCLAIMER OF WARRANTY: THIS WARRANTY COMPRISES THE SOLE AND ENTIRE WARRANTY PERTAINING TO PRODUCTS PROVIDED HEREUNDER. SELLER DISCLAIMS ALL OTHER WARRANTIES, EXPRESS AND IMPLIED, INCLUDING MERCHANTABILITY AND FITNESS FOR A PARTICULAR PURPOSE.**

5. Claims; Commencement of Actions. Buyer shall promptly inspect all Products upon delivery. No claims for shortages will be allowed unless reported to the Seller within 10 days of delivery. No other claims against Seller will

be allowed unless asserted in writing within 60 days after delivery or, in the case of an alleged breach of warranty, within 30 days after the date within the warranty period on which the defect is or should have been discovered by Buyer. Any action based upon breach of this agreement or upon any other claim arising out of this sale (other than an action by Seller for any amount due to Seller from Buyer) must be commenced within thirteen months from the date of tender of delivery by Seller or, for a cause of action based upon an alleged breach of warranty, within thirteen months from the date within the warranty period on which the defect is or should have been discovered by Buyer.

6. LIMITATION OF LIABILITY. UPON NOTIFICATION, SELLER WILL, AT ITS OPTION, REPAIR OR REPLACE A DEFECTIVE PRODUCT, OR REFUND THE PURCHASE PRICE. IN NO EVENT SHALL SELLER BE LIABLE TO BUYER FOR ANY SPECIAL, INDIRECT, INCIDENTAL OR CONSEQUENTIAL DAMAGES ARISING OUT OF, OR AS THE RESULT OF, THE SALE, DELIVERY, NON-DELIVERY, SERVICING, USE OR LOSS OF USE OF THE PRODUCTS OR ANY PART THEREOF, OR FOR ANY CHARGES OR EXPENSES OF ANY NATURE INCURRED WITHOUT SELLER'S WRITTEN CONSENT, EVEN IF SELLER HAS BEEN NEGLIGENT, WHETHER IN CONTRACT, TORT OR OTHER LEGAL THEORY. IN NO EVENT SHALL SELLER'S LIABILITY UNDER ANY CLAIM MADE BY BUYER EXCEED THE PURCHASE PRICE OF THE PRODUCTS.

7. Contingencies. Seller shall not be liable for any default or delay in performance if caused by circumstances beyond the reasonable control of Seller.

8. User Responsibility. The user, through its own analysis and testing, is solely responsible for making the final selection of the system and Product and assuring that all performance, endurance, maintenance, safety and warning requirements of the application are met. The user must analyze all aspects of the application and follow applicable industry standards and Product information. If Seller provides Product or system options, the user is responsible for determining that such data and specifications are suitable and sufficient for all applications and reasonably foreseeable uses of the Products or systems.

9. Loss to Buyer's Property. Any designs, tools, patterns, materials, drawings, confidential information or equipment furnished by Buyer or any other items which become Buyer's property, may be considered obsolete and may be destroyed by Seller after two consecutive years have elapsed without Buyer placing an order for the items which are manufactured using such property. Seller shall not be responsible for any loss or damage to such property while it is in Seller's possession or control.

10. Special Tooling. A tooling charge may be imposed for any special tooling, including without limitation, dies, fixtures, molds and patterns, acquired to manufacture Products.



Such special tooling shall be and remain Seller's property notwithstanding payment of any charges by Buyer. In no event will Buyer acquire any interest in apparatus belonging to Seller which is utilized in the manufacture of the Products, even if such apparatus has been specially converted or adapted for such manufacture and notwithstanding any charges paid by Buyer. Unless otherwise agreed, Seller shall have the right to alter, discard or otherwise dispose of any special tooling or other property in its sole discretion at any time.

11. Buyer's Obligation; Rights of Seller. To secure payment of all sums due or otherwise, Seller shall retain a security interest in the goods delivered and this agreement shall be deemed a Security Agreement under the Uniform Commercial Code. Buyer authorizes Seller as its attorney to execute and file on Buyer's behalf all documents Seller deems necessary to perfect its security interest. Seller shall have a security interest in, and lien upon, any property of Buyer in Seller's possession as security for the payment of any amounts owed to Seller by Buyer.

12. Improper use and Indemnity. Buyer shall indemnify, defend, and hold Seller harmless from any claim, liability, damages, lawsuits, and costs (including attorney fees), whether for personal injury, property damage, patent, trademark or copyright infringement or any other claim, brought by or incurred by Buyer, Buyer's employees, or any other person, arising out of: (a) improper selection, improper application or other misuse of Products purchased by Buyer from Seller; (b) any act or omission, negligent or otherwise, of Buyer; (c) Seller's use of patterns, plans, drawings, or specifications furnished by Buyer to manufacture Product; or (d) Buyer's failure to comply with these terms and conditions. Seller shall not indemnify Buyer under any circumstance except as otherwise provided.

13. Cancellations and Changes. Orders shall not be subject to cancellation or change by Buyer for any reason, except with Seller's written consent and upon terms that will indemnify, defend and hold Seller harmless against all direct, incidental and consequential loss or damage. Seller may change product features, specifications, designs and availability with notice to Buyer.

14. Limitation on Assignment. Buyer may not assign its rights or obligations under this agreement without the prior written consent of Seller.

15. Entire Agreement. This agreement contains the entire agreement between the Buyer and Seller and constitutes the final, complete and exclusive expression of the terms of the agreement. All prior or contemporaneous written or oral agreements or negotiations with respect to the subject matter are herein merged.

16. Waiver and Severability. Failure to enforce any provision of this agreement will not waive that provision nor will any such failure prejudice Seller's right to enforce that provision in the future. Invalidation of any provision of this agreement by legislation or other rule of law shall not invalidate any other provision herein. The remaining provisions of this agreement will remain in full force and effect.

17. Termination. This agreement may be terminated by Seller for any reason and at any time by giving Buyer thirty (30) days written notice of termination. In addition, Seller may

by written notice immediately terminate this agreement for the following: (a) Buyer commits a breach of any provision of this agreement (b) the appointment of a trustee, receiver or custodian for all or any part of Buyer's property (c) the filing of a petition for relief in bankruptcy of the other Party on its own behalf, or by a third party (d) an assignment for the benefit of creditors, or (e) the dissolution or liquidation of the Buyer.

18. Governing Law. This agreement and the sale and delivery of all Products hereunder shall be deemed to have taken place in and shall be governed and construed in accordance with the laws of the State of Ohio, as applicable to contracts executed and wholly performed therein and without regard to conflicts of laws principles. Buyer irrevocably agrees and consents to the exclusive jurisdiction and venue of the courts of Cuyahoga County, Ohio with respect to any dispute, controversy or claim arising out of or relating to this agreement. Disputes between the parties shall not be settled by arbitration unless, after a dispute has arisen, both parties expressly agree in writing to arbitrate the dispute.

19. Indemnity for Infringement of Intellectual Property Rights. Seller shall have no liability for infringement of any patents, trademarks, copyrights, trade dress, trade secrets or similar rights except as provided in this Section. Seller will defend and indemnify Buyer against allegations of infringement of U.S. patents, U.S. trademarks, copyrights, trade dress and trade secrets ("Intellectual Property Rights"). Seller will defend at its expense and will pay the cost of any settlement or damages awarded in an action brought against Buyer based on an allegation that a Product sold pursuant to this Agreement infringes the Intellectual Property Rights of a third party. Seller's obligation to defend and indemnify Buyer is contingent on Buyer notifying Seller within ten (10) days after Buyer becomes aware of such allegations of infringement, and Seller having sole control over the defense of any allegations or actions including all negotiations for settlement or compromise. If a Product is subject to a claim that it infringes the Intellectual Property Rights of a third party, Seller may, at its sole expense and option, procure for Buyer the right to continue using the Product, replace or modify the Product so as to make it noninfringing, or offer to accept return of the Product and return the purchase price less a reasonable allowance for depreciation. Notwithstanding the foregoing, Seller shall have no liability for claims of infringement based on information provided by Buyer, or directed to Products delivered hereunder for which the designs are specified in whole or part by Buyer, or infringements resulting from the modification, combination or use in a system of any Product sold hereunder. The foregoing provisions of this Section shall constitute Seller's sole and exclusive liability and Buyer's sole and exclusive remedy for infringement of Intellectual Property Rights.

20. Taxes. Unless otherwise indicated, all prices and charges are exclusive of excise, sales, use, property, occupational or like taxes which may be imposed by any taxing authority upon the manufacture, sale or delivery of Products.

21. Equal Opportunity Clause. For the performance of government contracts and where dollar value of the Products exceed \$10,000, the equal employment opportunity clauses in Executive Order 11246, VEVRAA, and 41 C.F.R. §§ 60-1.4(a), 60-741.5(a), and 60-250.4, are hereby incorporated.

Parker's Motion & Control Technologies

At Parker, we're guided by a relentless drive to help our customers become more productive and achieve higher levels of profitability by engineering the best systems for their requirements. It means looking at customer applications from many angles to find new ways to create value. Whatever the motion and control technology need, Parker has the experience, breadth of product and global reach to consistently deliver. No company knows more about motion and control technology than Parker. For further info call 1-800-C-Parker.



AEROSPACE

Key Markets

- Aircraft engines
- Business & general aviation
- Commercial transports
- Land-based weapons systems
- Military aircraft
- Missiles & launch vehicles
- Regional transports
- Unmanned aerial vehicles

Key Products

- Flight control systems & components
- Fluid conveyance systems
- Fluid metering delivery & atomization devices
- Fuel systems & components
- Hydraulic systems & components
- Inert nitrogen generating systems
- Pneumatic systems & components
- Wheels & brakes



CLIMATE CONTROL

Key Markets

- Agriculture
- Air conditioning
- Food, beverage & dairy
- Life sciences & medical
- Precision cooling
- Processing
- Transportation

Key Products

- CO₂ controls
- Electronic controllers
- Filter driers
- Hand shut-off valves
- Hose & fittings
- Pressure regulating valves
- Refrigerant distributors
- Safety relief valves
- Solenoid valves
- Thermostatic expansion valves

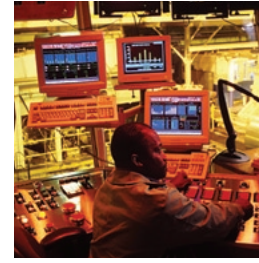

ELECTROMECHANICAL

Key Markets

- Aerospace
- Factory automation
- Life science & medical
- Machine tools
- Packaging machinery
- Paper machinery
- Plastics machinery & converting
- Primary metals
- Semiconductor & electronics
- Textile
- Wire & cable

Key Products

- AC/DC drives & systems
- Electric actuators, gantry robots & slides
- Electrohydraulic actuation systems
- Electromechanical actuation systems
- Human machine interface
- Linear motors
- Stepper motors, servo motors, drives & controls
- Structural extrusions



FILTRATION

Key Markets

- Food & beverage
- Industrial machinery
- Life sciences
- Marine
- Mobile equipment
- Oil & gas
- Power generation
- Process
- Transportation

Key Products

- Analytical gas generators
- Compressed air & gas filters
- Condition monitoring
- Engine air, fuel & oil filtration & systems
- Hydraulic, lubrication & coolant filters
- Process, chemical, water & microfiltration filters
- Nitrogen, hydrogen & zero air generators



FLUID & GAS HANDLING

Key Markets

- Aerospace
- Agriculture
- Bulk chemical handling
- Construction machinery
- Food & beverage
- Fuel & gas delivery
- Industrial machinery
- Mobile
- Oil & gas
- Transportation
- Welding

Key Products

- Brass fittings & valves
- Diagnostic equipment
- Fluid conveyance systems
- Industrial hose
- PTFE & PFA hose, tubing & plastic fittings
- Rubber & thermoplastic hose & couplings
- Tube fittings & adapters
- Quick disconnects



HYDRAULICS

Key Markets

- Aerospace
- Aerial lift
- Agriculture
- Construction machinery
- Forestry
- Industrial machinery
- Mining
- Oil & gas
- Power generation & energy
- Truck hydraulics

Key Products

- Diagnostic equipment
- Hydraulic cylinders & accumulators
- Hydraulic motors & pumps
- Hydraulic systems
- Hydraulic valves & controls
- Power take-offs
- Rubber & thermoplastic hose & couplings
- Tube fittings & adapters
- Quick disconnects

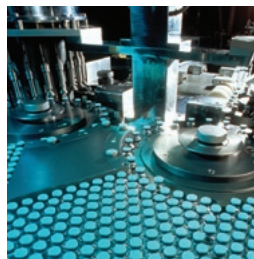

PNEUMATICS

Key Markets

- Aerospace
- Conveyor & material handling
- Factory automation
- Life science & medical
- Machine tools
- Packaging machinery
- Transportation & automotive

Key Products

- Air preparation
- Brass fittings & valves
- Manifolds
- Pneumatic accessories
- Pneumatic actuators & grippers
- Pneumatic valves & controls
- Quick disconnects
- Rotary actuators
- Rubber & thermoplastic hose & couplings
- Structural extrusions
- Thermoplastic tubing & fittings
- Vacuum generators, cups & sensors



PROCESS CONTROL

Key Markets

- Chemical & refining
- Food, beverage & dairy
- Medical & dental
- Microelectronics
- Oil & gas
- Power generation

Key Products

- Analytical sample conditioning products & systems
- Fluoropolymer chemical delivery fittings, valves & pumps
- High purity gas delivery fittings, valves & regulators
- Instrumentation fittings, valves & regulators
- Medium pressure fittings & valves
- Process control manifolds



SEALING & SHIELDING

Key Markets

- Aerospace
- Chemical processing
- Consumer
- Energy, oil & gas
- Fluid power
- General industrial
- Information technology
- Life sciences
- Military
- Semiconductor
- Telecommunications
- Transportation

Key Products

- Dynamic seals
- Elastomeric o-rings
- EMI shielding
- Extruded & precision-cut, fabricated elastomeric seals
- Homogeneous & inserted elastomeric shapes
- High temperature metal seals
- Metal & plastic retained composite seals
- Thermal management



ENGINEERING YOUR SUCCESS.

Sales Offices Worldwide

Parker Hannifin Corporation

Instrumentation Products Division
1005 A Cleaner Way
Huntsville, AL 35805
USA
phone 256 881 2040
fax 256 8815072
www.parker.com/ipdus

Parker Hannifin Corporation

Instrumentation Products Division
2651 Alabama Highway 21 North
Jacksonville, AL 36265-681
USA
phone 256 435 2130
fax 256 435 7718
www.parker.com/ipdus

Parker Hannifin Corporation

Instrumentation Products Division
6575 Tram Road
Beaumont, TX 77713
USA
phone 409 924 0300
fax 409 924 0301
www.parker.com/ipdus

Parker Hannifin plc

Instrumentation Products Division
Riverside Road
Pottington Business Park
Barnstaple, Devon EX31 1NP
England
phone +44 0 1271 313131
fax +44 0 1271 373636
email ipd@parker.com
www.parker.com/ipd

Catalog 4230/4233 15M December 2009 DP



Parker Hannifin Corporation
Instrumentation Products Division
1005 A Cleaner Way
Huntsville, AL 35805
phone 256 881 2040
fax 256 881 5072
www.parker.com/ipdus

Your Local Authorized Parker Distributor